



ARUF SERIES MULTI-POSITION AIR HANDLER

THREE-SPEED, 1½- TO 5-TON UNITS

Standard Features

- Suitable for use with refrigerants R-410A and R-22
- Check flowrate expansion device for cooling-only and heat pump applications
- Direct-drive, multi-speed motor
- Transformer and blower time-delay on all units
- AHRI Certified
- ETL Listed

Cabinet Features

- Rust-resistant, fully insulated steel cabinet
- Galvanized, leather grain-embossed finish
- Attractive Architectural Gray painted front panels
- Built-in coil has horizontal, vertical and downflow drain pans with secondary drain connections
- Built-in filter rack for 1" filter (filter not included)
- Power supply entry at top; low-voltage entry on left side and top

Accessories

- 3 kW to 21 kW electric heat kits available as field-installed options
- Permanent washable plastic air filters
- Thermal Expansion Valve Kits for air conditioning and heat pump applications
- Coil Insulation Kits for downflow applications
- Horizontal drain pan insulation kits



Contents

Nomenclature	2
Product Specifications	3
Dimensions	4
Airflow Data	5
Wiring Diagram	6
Accessories	7



* Complete warranty details available from your local dealer or at www.amana-hac.com. To receive the 10-Year Parts Limited Warranty, online registration must be completed within 60 days of installation. Online registration is not required in California or Québec.

NOMENCLATURE

	A	R	U	F	3642	1	6	AA	
	1	2	3	4	5,6,7,8	9	10	11,12	
Brand	A Single-piece Air Handler								Engineering * Major/ Minor Revisions * Not used for inventory management
Unit Application	C Ceiling Mount PSC Motor D Downflow PSC Motor E Multi-Position Variable-Speed Motor R Multi-Position PSC Motor S Multi-Position EEM Motor W Wall Mount PSC Motor								Refrigerant Charge No Digit = R-22 only 6 = R-410A or R-22
Cabinet Finish	U Unpainted P Painted N Uncased								Electrical 1 208/240 V, 1 Phase, 60 Hz
Expansion Device	F Flowrater T Expansion Valve								Nominal Capacity Range @ 13 SEER Multi-Position & Downflow Applications 1729 1½ to 2½ Tons (for Export Systems) 1830 1½-3½ Tons 3642 3-3½ Tons Ceiling Mount & Wall Mount Applications (Nominal Cooling Capacity/ Electric Heat kW) 1805 1½ Tons Cooling/ 5 kW Electric Heat 2405 2 Tons Cooling/ 5 kW Electric Heat 3608 3 Tons Cooling/ 8 kW Electric Heat

SPECIFICATIONS

	ARUF 172916*	ARUF 182416*	ARUF 193116*	ARUF 303016*	ARUF 363616*
NOMINAL RATINGS					
Cooling (Btu/h)	18,000 - 30,000	18,000 - 24,000	18,000 - 30,000	30,000	36,000
CFM (High/ Med/ Low)	1,025/ 790/ 570	1,025/ 790/ 570	1,025/ 780/ 545	1,330/ 1,239/ 980	1,230/ 1,140/ 955
BLOWER					
Diameter	9½"	9½"	9½"	9½"	9½"
Width	6"	6"	6"	8"	6"
Coil Drain Connect FPT	¾"	¾"	¾"	¾"	¾"
SERVICE VALVE					
Liquid	⅜"	⅜"	⅜"	⅜"	⅜"
Suction	¾"	¾"	⅞"	¾"	¾"
ELECTRICAL DATA					
Voltage	208/240	208/240	208/240	208/240	208/240
Min Circuit Ampacity	2.1/2.1	2.1/2.1	1.9/1.9	3.3/3.3	3.3/3.3
Max. Overcurrent Device (amps)	15/15	15/15	15/15	15/15	15/15
Min. / Max VAC	197/ 253	197/ 253	197/ 253	197/ 253	197/ 253
Blower Motor FLA/ HP	1.7/ ⅓	1.7/ ⅓	1.48/ ¼	2.64/ ⅓	2.64/ ⅓
SHIP WEIGHT (LBS)	110	116	155	144	164

	ARUF 364216*	ARUF 374316*	ARUF 486016*	ARUF 496116*
NOMINAL RATINGS				
Cooling (Btu/h)	36,000 - 42,000	36,000 - 42,000	48,000 - 60,000	48,000 - 60,000
CFM (High/ Med/ Low)	1625 / 1400 / 1250	1,925/ 1,550/ 1,345	1,985/ 1,875/ 1,650	1,915/ 1,795/ 1,585
BLOWER				
Diameter	10⅝"	11 15/16"	10⅝"	10⅝"
Width	8"	10 11/16"	10⅝"	10⅝"
Coil Drain Connect FPT	¾"	¾"	¾"	¾"
SERVICE VALVE				
Liquid	⅜"	⅜"	⅜"	⅜"
Suction	⅞"	⅞"	⅞"	⅞"
ELECTRICAL DATA				
Voltage	208/240	208/240	208/240	208/240
Min Circuit Ampacity	3.7/3.7	4.2/4.2	5.4/5.4	5.4/5.4
Max. Overcurrent Device (amps)	15/15	15/15	15/15	15/15
Min. / Max VAC	197/ 253	197/ 253	197/ 253	197/ 253
Blower Motor FLA/ HP	2.95/ ⅓	3.39/ ⅓	4.3/ ¼	4.3/ ¼
SHIP WEIGHT (LBS)	160	195	183	192

DIMENSIONS

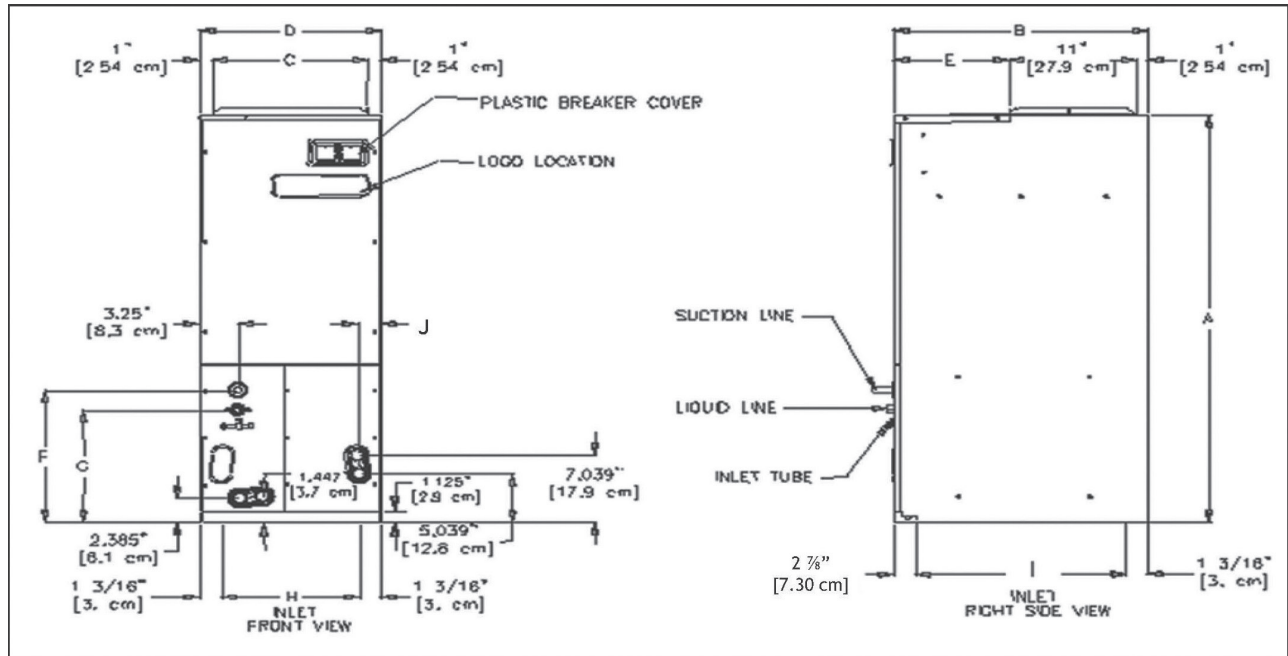

MODEL	A	B	C	D	E	F	G	H	I	J
ARUF172916*	42 ¹ / ₈ "	22"	13 ¹ / ₂ "	15 ¹ / ₂ "	10"	14 ¹ / ₂ "	11 ¹⁵ / ₁₆ "	13 ³ / ₈ "	17 ¹⁵ / ₁₆ "	2"
ARUF182416*	42 ¹ / ₈ "	22"	13 ¹ / ₂ "	15 ¹ / ₂ "	10"	14 ¹ / ₂ "	11 ¹⁵ / ₁₆ "	13 ³ / ₈ "	17 ¹⁵ / ₁₆ "	2"
ARUF193116*	46 ³ / ₄ "	22"	17 ¹ / ₂ "	19 ¹ / ₂ "	10"	14 ¹ / ₂ "	11 ¹⁵ / ₁₆ "	17 ⁷ / ₈ "	17 ¹⁵ / ₁₆ "	2"
ARUF303016*	46 ³ / ₄ "	22"	17 ¹ / ₂ "	19 ¹ / ₂ "	10"	14 ¹ / ₂ "	11 ¹⁵ / ₁₆ "	17 ⁷ / ₈ "	17 ¹⁵ / ₁₆ "	2"
ARUF363616*	46 ³ / ₄ "	22"	17 ¹ / ₂ "	19 ¹ / ₂ "	10"	14 ¹ / ₂ "	11 ¹⁵ / ₁₆ "	17 ⁷ / ₈ "	17 ¹⁵ / ₁₆ "	1 ⁴ / ₅ "
ARUF364216*	53 ³ / ₄ "	24"	20"	22"	12"	14 ¹ / ₂ "	11 ¹⁵ / ₁₆ "	19 ³ / ₈ "	19 ¹⁵ / ₁₆ "	1 ⁴ / ₅ "
ARUF374316*	53 ³ / ₄ "	24"	20"	22"	12"	14 ¹ / ₂ "	11 ¹⁵ / ₁₆ "	19 ³ / ₈ "	19 ¹⁵ / ₁₆ "	1 ⁴ / ₅ "
ARUF486016*	53 ³ / ₄ "	24"	20"	22"	12"	14 ¹ / ₂ "	11 ¹⁵ / ₁₆ "	19 ³ / ₈ "	19 ¹⁵ / ₁₆ "	1 ⁴ / ₅ "
ARUF496116*	53 ³ / ₄ "	24"	20"	22"	12"	14 ¹ / ₂ "	11 ¹⁵ / ₁₆ "	19 ³ / ₈ "	19 ¹⁵ / ₁₆ "	1 ⁴ / ₅ "
ARUF496116*	53 ³ / ₄ "	24"	20"	22"	12"	14 ¹ / ₂ "	11 ¹⁵ / ₁₆ "	19 ³ / ₈ "	19 ¹⁵ / ₁₆ "	1 ⁴ / ₅ "

AIRFLOW DATA

MODEL	MOTOR SPEED	CFM DELIVERED AGAINST EXTERNAL STATIC PRESSURE				
		0.1"	0.2"	0.3"	0.4"	0.5"
ARUF172916*	High	1,155	1,090	1,025	950	895
	Med	940	890	860	815	755
	Low	695	665	650	610	550
ARUF182416*	High	1,155	1,090	1,025	950	895
	Med	940	890	860	815	755
	Low	695	665	650	610	550
ARUF193116*	High	1,135	1,085	1,025	965	915
	Med	860	825	780	750	680
	Low	600	570	545	500	465
ARUF303016*	High	1,385	1,315	1,240	1,155	1,065
	Med	1,340	1,290	1,230	1,140	1,050
	Low	1,075	1,030	980	910	840
ARUF363616*	High	1,310	1,240	1,155	1,090	1,020
	Med	1,270	1,210	1,140	1,075	980
	Low	1,045	1,005	955	885	805
ARUF364216*	High	1,700	1,660	1,625	1,545	1,505
	Med	1,500	1,440	1,400	1,350	1,345
	Low	1,370	1,300	1,250	1,230	1,220
ARUF374316*	High	2,065	2,000	1,925	1,860	1,780
	Med	1,685	1,635	1,550	1,470	1,410
	Low	1,490	1,425	1,345	1,280	1,205
ARUF486016*	High	2,150	2,120	2,070	2,000	1,940
	Med	1,940	1,930	1,905	1,860	1,790
	Low	1,610	1,600	1,590	1,575	1,550
ARUF496116*	High	2,150	2,105	2,040	1,970	1,880
	Med	1,960	1,935	1,895	1,825	1,750
	Low	1,670	1,625	1,585	1,525	1,455

Note: Assumes dry coil with filter in place; SCFM correction for wet coil = 4% (208V / 240V)

ARUF WIRING DIAGRAM

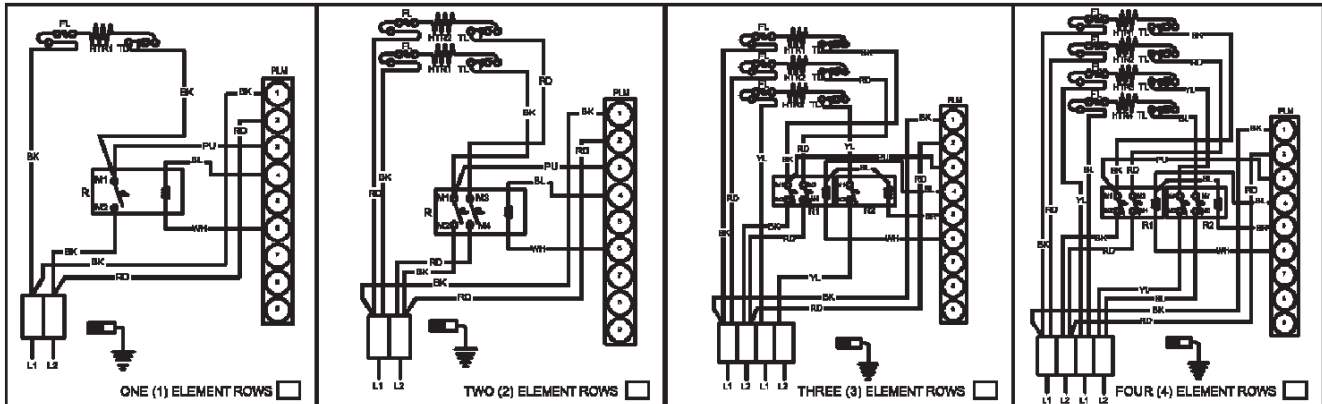

NOTE: WHEN INSTALLING HEATER KIT, ENSURE SPEED TAP DOES NOT EXCEED MINIMUM BLOWER SPEED (MBS) SPECIFIED FOR THE AIRHANDLER/HEATER KIT COMBINATION ON THIS UNIT'S S&R PLATE. AFTER INSTALLING OPTIONAL HEAT KIT, MARK AN "X" IN THE PROVIDED ABOVE. MARK ACCORDING TO NUMBER OF HEATER ELEMENT ROWS INSTALLED. NO MARK INDICATES NO HEAT KIT INSTALLED.

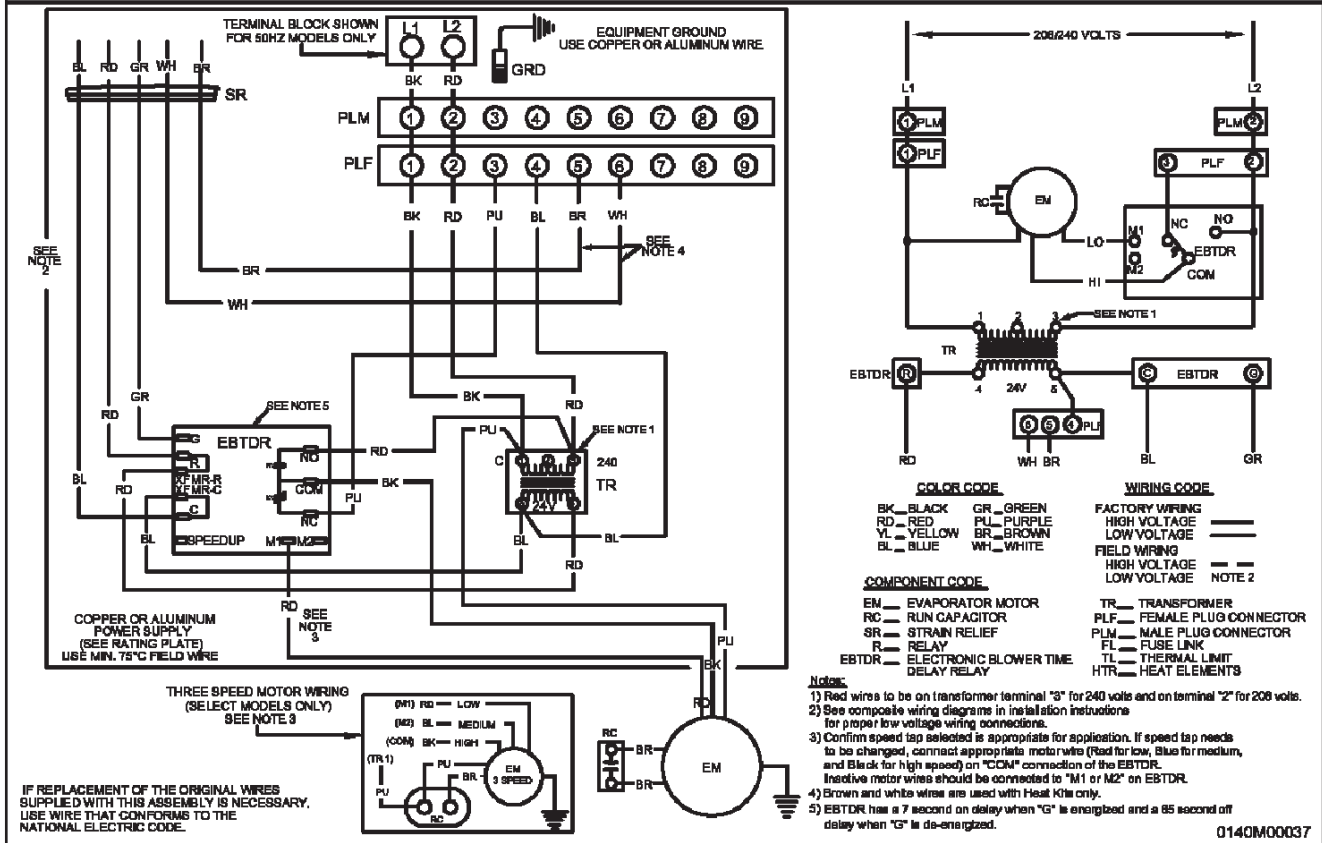

0140M00037

Wiring is subject to change. Always refer to the wiring diagram or the unit for the most up-to-date wiring.



WARNING

High Voltage: Disconnect all power before servicing or installing this unit. Multiple power sources may be present. Failure to do so may cause property damage, personal injury, or death.



ACCESSORIES

HEAT KIT APPLICATIONS

	ARUF 172916*	ARUF 182416*	ARUF 193116*	ARUF 303016*	ARUF 363616*	ARUF 364216*	ARUF 374316*	ARUF 486016*	ARUF 496116*
HKR-03*	X	X	X	X	X	X	X	X	X
HKR-05*, HKR-05C*	X	X	X	X	X	X	X	X	X
HKR-06*	X	X	X	X	X	X	X	X	X
HKR-08*, HKR-08C*	X ¹	X ¹	X ¹	X	X	X	X	X	X
HKR-10*, HKR-10C*	X ¹	X ¹	X ¹	X ¹	X	X	X	X	X
HKR-15C*	X ²	X ²	X ²	X ²	X ²	X ³	X ³	X	X
HKR-20C*				X ²		X ³	X ³	X	X
HKR-21C*				X ²		X ³	X ³	X	X
^ HKR3-15*				X ²	X ²	X ³	X ³	X	X
^ HKR3-20*				X ²		X ³	X ³	X	X

* Revision level that may or may not be designated
 C Circuit breaker option
 ^ Heat kit requires three-phase power supply

¹ Air handler must either be on medium or high speed
² Air handler must be on high speed
³ For static pressure of 0.6 or higher, air handler must be on medium or high speed

EXPANSION VALVE KITS FOR AIR CONDITIONING AND HEAT PUMP APPLICATIONS

KIT NUMBER	DESCRIPTION	APPLICATION	REFRIGERANT	TONNAGE: OUTDOOR UNIT
XVB18-36C	20% Bleed Valve	AC Only	R-22	1½ - 3 Ton
XVB42-60C	20% Bleed Valve	AC Only	R-22	3½ - 5 Ton
XV18-36C	Non-bleed Valve	AC Only	R-22	1½ - 3 Ton
XV42-60C	Non-bleed Valve	AC Only	R-22	3½ - 5 Ton
TX2N2	Non-bleed Valve	AC or HP	R-22	1½ - 2 Ton
TX3N2	Non-bleed Valve	AC or HP	R-22	2½ - 3 Ton
TX5N2	Non-bleed Valve	AC or HP	R-22	3½ - 5 Ton
TX2N4	Non-bleed Valve	AC or HP	R-410A	1½ - 2 Ton
TX3N4	Non-bleed Valve	AC or HP	R-410A	2½ - 3 Ton
TX5N4	Non-bleed Valve	AC or HP	R-410A	3½ - 5 Ton

SINGLE POINT KIT **

MODEL	HKR-15C	HKR-20C	HKR-21C
SPW-01	X	X	X

** Must be installed along with any of the above compatible heat kits. This kit will fit any ARUF air handler as long as a compatible heat kit is installed in the unit.

DRAIN PAN INSULATION KIT FOR DOWNFLOW APPLICATIONS

CHASSIS SIZE	INSULATION KIT
Small (15½")	DPI18-30/20
Medium (19½")	DPI36-42/20
Large (22")	DPI48-60/20

Note: Each kit contains enough material to modify 20 coils

FILTERS

MODEL	FILTER #	QTY REQUIRED
1729/ 1824	FIL 18-32	1
1931	FIL-36-42	1
3030/ 3636	FIL-36-42	1
3642/ 3743	FIL 48-61	1
4860/4961	FIL 48-61	1

NOTES



Amana® is a trademark of Maytag Corporation or its related companies and used under license to Goodman Company, L.P. All rights reserved. Our continuing commitment to quality products may mean a change in specifications without notice. © 2010 • Goodman Company, L.P. • Houston, Texas • Printed in the USA.

