



ASZ13

SPLIT SYSTEM HEAT PUMP

13 SEER / R-410A

COOLING CAPACITY: 18,000 - 60,000 BTU/H

HEATING CAPACITY: 18,000 - 59,000 BTU/H

Standard Features

- R-410A chlorine-free refrigerant
- High-efficiency scroll compressor
- Copeland ComfortAlert diagnostics
- SmartShift™ technology to ensure quiet reliable defrost
- Factory-installed bi-flow liquid line filter dryer
- Factory-installed suction line accumulator
- Factory-installed compressor crankcase heater
- Factory-installed high-capacity muffler
- High- and low-pressure switches
- Service valves with sweat connections and easy access to gauge ports
- Copper tube/enhanced aluminum fin coil
- Fully charged for 15' of tubing length
- Contactor with lug connection
- Ground lug connection
- AHRI Certified; ETL Listed

Cabinet Features

- Amana brand sound control top design
- Wire fan discharge grille
- Steel louver coil guard
- Baked-on powder-paint finish
- Rust-resistant screws
- Compact footprint
- Top and side maintenance access
- Single-panel access to controls with space provided for field-installed accessories
- When properly anchored, meets the 2001 Florida Building Code unit integrity requirements for hurricane-type winds (Anchor bracket kits available.)



Contents

Nomenclature	2
Product Specifications	3
Expanded Cooling Data	4
Expanded Heating Data	18
AHRI Performance Ratings	20
Wiring Diagram	27
Dimensions	28
Accessories	28



* To receive the 10-Year Parts Limited Warranty, online registration must be completed within 60 days of installation. Online registration is not required in California or Québec. Full warranty details are available at www.amana-hac.com.

NOMENCLATURE

	A	S	Z	13	036	1	AA
	1	2	3	4,5	6,7,8	9	10,11
Brand	A Amana® Brand			Engineering *			
				Major/ Minor Revisions			
				* Neither revision is used for order entry or inventory management.			
Product Category	S Split System		Electrical				
			1 208/230 V, 1 Phase, 60 Hz				
			2 220/240 V, 1 Phase, 50 Hz				
			3 208/230 V, 3 Phase, 60 Hz				
			4 460 V, 3 Phase, 60 Hz				
			5 380/415 V, 3 Phase, 50 Hz				
Unit Type	C Condenser R-22			Nominal Capacity			
	X Condenser R-410A			018 1½ Tons 048 4 Tons			
	H Heat Pump R-22			024 2 Tons 060 5 Tons			
	Z Heat Pump R-410A			030 2½ Tons 090 7½ tons			
				036 3 Tons 120 10 Tons			
				042 3½ Tons			
Efficiency	13 13 SEER						
	14 14 SEER						
	16 16 SEER						
	18 18 SEER						

SPECIFICATIONS

	ASZ13 0181A*	ASZ13 0241A*	ASZ13 0301A*	ASZ13 0361A*	ASZ13 0421A*	ASZ13 0481A*	ASZ13 0601A*
NOMINAL CAPACITIES							
Cooling (BTU/h)	17,400	23,000	28,400	35,000	40,500	46,000	57,000
Heating (BTU/h)	17,000	23,000	26,400	34,000	40,000	44,000	58,000
Decibels	70	70	71	71	72	74	75
COMPRESSOR							
RLA	9.0	12.8	14.1	16.7	17.9	19.9	26.4
LRA	48.0	58.3	73.0	79.0	112.0	109.0	134.0
CONDENSER FAN MOTOR							
Horsepower	1/6	1/6	1/6	¼	¼	¼	¼
FLA	0.9	0.9	0.9	1.50	1.50	1.50	1.50
REFRIGERATION SYSTEM							
Refrigerant Line Size ¹							
Liquid Line Size ("O.D.)	¾"	¾"	¾"	¾"	¾"	¾"	¾"
Suction Line Size ("O.D.)	¾"	¾"	¾"	7/8"	1 1/8"	1 1/8"	1 1/8"
Refrigerant Connection Size							
Liquid Valve Size ("O.D.)	¾"	¾"	¾"	¾"	¾"	¾"	¾"
Suction Valve Size ("O.D.)	¾"	¾"	¾"	¾"	7/8"	7/8"	7/8"
Valve Connection Type	Sweat	Sweat	Sweat	Sweat	Sweat	Sweat	Sweat
Refrigerant Charge	119	119	124	168	171	219	242
Shipped with Orifice Size	0.049	0.057	0.063	0.068	0.074	0.078	0.088
ELECTRICAL DATA							
Volts / Hz / Phase	208/230-60-1				208/230-60-1		
Minimum Circuit Ampacity ²	12.2	16.9	18.5	22.4	23.9	26.4	34.5
Max. Overcurrent Protection ³	20	25	30	35	40	45	60
Min / Max Volts	197 / 253	197 / 253	197 / 253	197 / 253	197 / 253	197 / 253	197 / 253
Electrical Conduit Size	½" or ¾"	½" or ¾"	½" or ¾"	½" or ¾"	½" or ¾"	½" or ¾"	½" or ¾"
SHIP WEIGHT (LBS)	178	176	177	216	240	256	310

¹ Tested and rated in accordance with AHRI Standard 210/240

² Wire size should be determined in accordance with National Electrical Codes; extensive wire runs will require larger wire sizes

³ Must use time-delay fuses or HACR-type circuit breakers of the same size as noted.

NOTES

- Always check the rating plate for electrical data on the unit being installed.
- Installer will need to supply ¾" to 1 1/8" adapters for suction line connections.
- Unit is charged with refrigerant for 15' of ¾" liquid line. System charge must be adjusted per Installation Instructions Final Charge Procedure.
- Installation of these units requires the specified TXV Kit to be installed on the indoor coil. THE SPECIFIED TXV IS DETERMINED BY THE OUTDOOR UNIT NOT THE INDOOR COIL.

EXPANDED COOLING DATA — ASZ130181A* / AR*F182416**

IDB	AIRFLOW	OUTDOOR AMBIENT TEMPERATURE																							
		65°F				75°F				85°F				95°F				105°F				115°F			
		59	63	67	71	59	63	67	71	59	63	67	71	59	63	67	71	59	63	67	71	59	63	67	71
70	MBh	17.1	17.7	19.4	-	16.7	17.3	18.9	-	16.3	16.9	18.5	-	15.9	16.4	18.0	-	15.1	15.6	17.1	-	14.0	14.5	15.9	-
	S/T	0.74	0.62	0.43	-	0.77	0.64	0.45	-	0.79	0.66	0.46	-	0.82	0.68	0.47	-	0.85	0.71	0.49	-	0.85	0.71	0.49	-
	ΔT	17	15	11	-	17	15	11	-	17	15	11	-	18	15	12	-	17	15	11	-	16	14	11	-
	kW	1.23	1.26	1.30	-	1.33	1.35	1.40	-	1.41	1.44	1.49	-	1.49	1.52	1.57	-	1.55	1.59	1.64	-	1.61	1.64	1.70	-
	Amps	5.5	5.6	5.8	-	5.9	6.0	6.2	-	6.3	6.5	6.6	-	6.7	6.9	7.1	-	7.1	7.3	7.5	-	7.5	7.6	7.9	-
	HI PR	216	232	245	-	242	261	275	-	275	296	313	-	314	337	356	-	353	380	401	-	390	419	443	-
	Lo PR	108	115	126	-	114	122	133	-	119	126	138	-	125	133	145	-	131	139	152	-	135	144	157	-
	MBh	16.6	17.2	18.8	-	16.2	16.8	18.4	-	15.8	16.4	17.9	-	15.4	16.0	17.5	-	14.6	15.2	16.6	-	13.6	14.0	15.4	-
	S/T	0.71	0.59	0.41	-	0.73	0.61	0.43	-	0.75	0.63	0.44	-	0.78	0.65	0.45	-	0.81	0.67	0.47	-	0.81	0.68	0.47	-
	ΔT	18	16	12	-	18	16	12	-	18	16	12	-	18	16	12	-	18	16	12	-	17	15	11	-
kW	1.22	1.25	1.29	-	1.31	1.34	1.39	-	1.40	1.43	1.48	-	1.47	1.51	1.56	-	1.54	1.57	1.63	-	1.59	1.63	1.68	-	
Amps	5.4	5.5	5.7	-	5.8	5.9	6.1	-	6.3	6.4	6.6	-	6.6	6.8	7.0	-	7.0	7.2	7.4	-	7.4	7.6	7.8	-	
HI PR	214	230	243	-	240	258	272	-	273	293	310	-	310	334	353	-	349	376	397	-	386	415	439	-	
Lo PR	107	114	124	-	113	120	132	-	118	125	137	-	124	132	144	-	130	138	150	-	134	143	156	-	
MBh	15.3	15.8	17.4	-	14.9	15.5	16.9	-	14.6	15.1	16.5	-	14.2	14.7	16.1	-	13.5	14.0	15.3	-	12.5	13.0	14.2	-	
S/T	0.68	0.57	0.40	-	0.71	0.59	0.41	-	0.73	0.61	0.42	-	0.75	0.63	0.43	-	0.78	0.65	0.45	-	0.78	0.66	0.45	-	
ΔT	18	16	12	-	19	16	12	-	19	16	12	-	19	16	12	-	19	16	12	-	17	15	11	-	
kW	1.19	1.21	1.25	-	1.28	1.31	1.35	-	1.36	1.39	1.44	-	1.44	1.47	1.52	-	1.50	1.53	1.58	-	1.55	1.59	1.64	-	
Amps	5.3	5.4	5.6	-	5.7	5.8	6.0	-	6.1	6.2	6.4	-	6.5	6.6	6.8	-	6.9	7.0	7.2	-	7.2	7.4	7.6	-	
HI PR	207	223	235	-	232	250	264	-	264	285	300	-	301	324	342	-	339	365	385	-	374	403	425	-	
Lo PR	104	111	121	-	110	117	128	-	114	121	133	-	120	128	139	-	126	134	146	-	130	138	151	-	

75	MBh	17.34	17.85	19.32	20.74	16.94	17.44	18.87	20.26	16.53	17.02	18.43	19.78	16.13	16.61	17.98	19.29	15.32	15.78	17.08	18.33	14.19	14.61	15.82	16.98
	S/T	0.84	0.76	0.57	0.37	0.88	0.78	0.59	0.38	0.90	0.80	0.61	0.39	0.93	0.83	0.63	0.40	0.96	0.86	0.65	0.42	0.97	0.87	0.66	0.42
	ΔT	20	18	15	10	20	19	15	11	20	19	15	11	20	19	15	11	20	18	15	10	19	17	14	10
	kW	1.24	1.27	1.31	1.35	1.34	1.37	1.41	1.46	1.42	1.45	1.50	1.55	1.50	1.53	1.58	1.64	1.56	1.60	1.65	1.71	1.62	1.66	1.71	1.77
	Amps	5.5	5.6	5.8	6.0	5.9	6.0	6.2	6.4	6.4	6.5	6.7	6.9	6.8	6.9	7.1	7.4	7.2	7.3	7.5	7.8	7.5	7.7	8.0	8.2
	HI PR	218	235	248	258	245	263	278	290	278	299	316	330	317	341	360	375	356	383	405	422	394	424	447	467
	Lo PR	109	116	127	135	116	123	134	143	120	128	139	149	126	134	146	156	132	141	154	163	137	145	159	169
	MBh	16.8	17.3	18.8	20.1	16.4	16.9	18.3	19.7	16.1	16.5	17.9	19.2	15.7	16.1	17.5	18.7	14.9	15.3	16.6	17.8	13.8	14.2	15.4	16.5
	S/T	0.81	0.72	0.55	0.35	0.84	0.75	0.57	0.36	0.86	0.77	0.58	0.37	0.88	0.79	0.60	0.38	0.92	0.82	0.62	0.40	0.93	0.83	0.63	0.40
	ΔT	21	19	16	11	21	19	16	11	21	19	16	11	21	20	16	11	21	19	16	11	20	18	15	10
kW	1.23	1.26	1.30	1.34	1.33	1.35	1.40	1.45	1.41	1.44	1.49	1.54	1.49	1.52	1.57	1.63	1.55	1.59	1.64	1.70	1.61	1.64	1.70	1.76	
Amps	5.5	5.6	5.8	5.9	5.9	6.0	6.2	6.4	6.3	6.5	6.6	6.9	6.7	6.9	7.1	7.3	7.1	7.3	7.5	7.7	7.5	7.6	7.9	8.2	
HI PR	216	232	245	256	242	261	275	287	275	296	313	326	314	338	356	372	353	380	401	418	390	420	443	462	
Lo PR	108	115	126	134	114	122	133	141	119	126	138	147	125	133	145	154	131	139	152	162	135	144	157	167	
MBh	15.5	16.0	17.3	18.6	15.2	15.6	16.9	18.2	14.8	15.3	16.5	17.7	14.5	14.88	16.1	17.3	13.7	14.1	15.3	16.4	12.7	13.1	14.2	15.2	
S/T	0.78	0.69	0.53	0.34	0.81	0.72	0.55	0.35	0.83	0.74	0.56	0.36	0.85	0.76	0.58	0.37	0.88	0.79	0.60	0.39	0.89	0.80	0.60	0.39	
ΔT	21	19	16	11	21	20	16	11	21	20	16	11	22	20	16	11	22	20	16	11	20	18	15	10	
kW	1.20	1.22	1.26	1.31	1.29	1.32	1.36	1.41	1.38	1.41	1.45	1.50	1.45	1.48	1.53	1.58	1.51	1.55	1.60	1.65	1.57	1.60	1.65	1.71	
Amps	5.3	5.5	5.6	5.8	5.7	5.8	6.0	6.2	6.2	6.3	6.5	6.7	6.5	6.7	6.9	7.1	6.9	7.1	7.3	7.5	7.3	7.5	7.7	7.9	
HI PR	209	225	238	248	235	253	267	278	267	287	304	317	304	327	346	361	342	368	389	406	378	407	430	448	
Lo PR	105	112	122	130	111	118	129	137	115	123	134	143	121	129	141	150	127	135	147	157	131	140	153	162	

IDB: Entering Indoor Dry Bulb Temperature
 High and low pressures are measured at the liquid and suction service valves.
 Shaded area reflects ACCA (TVA) conditions
 kW=Total system power
 Amps = outdoor unit amps (compressor + fan)

EXPANDED COOLING DATA — ASZ130181A* / AR*F182416** (CONT.)

IDB	AIRFLOW	OUTDOOR AMBIENT TEMPERATURE												ENTERING INDOOR WET BULB TEMPERATURE											
		65°F				75°F				85°F				95°F				105°F				115°F			
		59	63	67	71	59	63	67	71	59	63	67	71	59	63	67	71	59	63	67	71	59	63	67	71
675	MBh	17.65	18.03	19.27	20.60	17.24	17.61	18.82	20.12	16.83	17.19	18.37	19.64	16.42	16.77	17.92	19.16	15.60	15.94	17.03	18.20	14.45	14.76	15.77	16.86
	S/T	0.93	0.87	0.71	0.53	0.96	0.90	0.73	0.55	1.00	0.92	0.75	0.56	1.00	0.95	0.78	0.58	1.00	1.00	0.81	0.60	1.00	1.00	0.81	0.61
	ΔT	22	21	19	15	23	22	19	15	23	22	19	15	22	22	19	15	21	22	19	15	20	20	17	14
	kW	1.25	1.28	1.32	1.36	1.35	1.38	1.42	1.47	1.44	1.47	1.52	1.57	1.51	1.55	1.60	1.65	1.58	1.61	1.67	1.73	1.63	1.67	1.73	1.79
	Amps	5.6	5.7	5.8	6.0	6.0	6.1	6.3	6.5	6.4	6.6	6.8	7.0	6.8	7.0	7.2	7.4	7.2	7.4	7.6	7.9	7.6	7.8	8.0	8.3
	Hi PR	220	237	250	261	247	266	281	293	281	302	319	333	320	344	364	379	360	387	409	427	398	428	452	471
	Lo PR	110	118	128	137	117	124	136	144	121	129	141	150	127	136	148	158	134	142	155	165	138	147	160	171
	MBh	17.1	17.5	18.7	20.0	16.7	17.1	18.3	19.5	16.3	16.7	17.8	19.1	15.9	16.3	17.4	18.6	15.1	15.5	16.5	17.7	14.0	14.3	15.3	16.4
	S/T	0.88	0.83	0.67	0.50	0.92	0.86	0.70	0.52	0.94	0.88	0.72	0.54	0.97	0.91	0.74	0.55	1.00	0.94	0.77	0.57	1.00	0.95	0.77	0.58
	ΔT	23	22	19	15	23	23	20	16	24	23	20	16	24	23	20	16	23	22	19	16	21	21	18	15
80	kW	1.24	1.27	1.31	1.35	1.34	1.37	1.41	1.46	1.42	1.46	1.50	1.55	1.50	1.53	1.59	1.64	1.56	1.60	1.65	1.71	1.62	1.66	1.71	1.77
	Amps	5.5	5.6	5.8	6.0	5.9	6.0	6.2	6.4	6.4	6.5	6.7	6.9	6.8	6.9	7.1	7.4	7.2	7.3	7.5	7.8	7.5	7.7	8.0	8.2
	Hi PR	218	235	248	258	245	263	278	290	278	299	316	330	317	341	360	375	356	384	405	422	394	424	447	467
	Lo PR	109	116	127	135	116	123	134	143	120	128	139	149	126	134	147	156	132	141	154	164	137	145	159	169
	MBh	15.8	16.2	17.3	18.5	15.4	15.8	16.9	18.0	15.1	15.4	16.5	17.6	14.7	15.0	16.1	17.2	14.0	14.3	15.3	16.3	12.9	13.2	14.1	15.1
	S/T	0.85	0.80	0.65	0.49	0.88	0.83	0.67	0.50	0.91	0.85	0.69	0.52	0.93	0.88	0.71	0.53	0.97	0.91	0.74	0.55	0.98	0.92	0.75	0.56
	ΔT	24	23	20	16	24	23	20	16	24	23	20	16	24	23	20	16	24	23	20	16	22	21	18	15
	kW	1.21	1.23	1.27	1.32	1.30	1.33	1.38	1.42	1.39	1.42	1.47	1.51	1.46	1.49	1.54	1.60	1.52	1.56	1.61	1.67	1.58	1.61	1.67	1.73
	Amps	5.4	5.5	5.7	5.8	5.8	5.9	6.1	6.3	6.2	6.3	6.5	6.8	6.6	6.7	6.9	7.2	7.0	7.1	7.3	7.6	7.4	7.5	7.7	8.0
	Hi PR	211	228	240	251	237	255	270	281	270	290	307	320	307	331	349	364	346	372	393	410	382	411	434	453
Lo PR	106	113	123	131	112	119	130	139	116	124	135	144	122	130	142	151	128	136	149	159	133	141	154	164	

675	MBh	17.96	18.30	19.17	20.45	17.54	17.88	18.72	19.98	17.12	17.45	18.28	19.50	16.70	17.03	17.83	19.02	15.87	16.18	16.94	18.07	14.70	14.98	15.69	16.74
	S/T	0.97	0.94	0.85	0.69	1.00	0.97	0.88	0.71	1.00	1.00	0.90	0.73	1.00	1.00	0.93	0.75	1.00	1.00	0.96	0.78	1.00	1.00	0.97	0.79
	ΔT	24	23	22	19	24	24	22	19	23	24	22	19	23	23	23	20	22	22	22	19	20	20	21	18
	kW	1.26	1.29	1.33	1.37	1.36	1.39	1.44	1.48	1.45	1.48	1.53	1.58	1.53	1.56	1.61	1.67	1.59	1.63	1.68	1.74	1.65	1.69	1.74	1.80
	Amps	5.6	5.7	5.9	6.1	6.0	6.1	6.3	6.5	6.5	6.6	6.8	7.0	6.9	7.0	7.2	7.5	7.3	7.4	7.7	7.9	7.7	7.8	8.1	8.4
	Hi PR	222	239	253	264	249	268	284	296	284	305	322	336	323	348	367	383	364	391	413	431	402	432	456	476
	Lo PR	112	119	130	138	118	125	137	146	122	130	142	152	129	137	149	159	135	143	157	167	139	148	162	173
	MBh	17.4	17.8	18.6	19.9	17.0	17.4	18.2	19.4	16.6	16.9	17.7	18.9	16.2	16.5	17.3	18.5	15.4	15.7	16.4	17.5	14.3	14.5	15.2	16.3
	S/T	0.93	0.89	0.81	0.65	0.96	0.93	0.84	0.68	0.98	0.95	0.86	0.70	1.00	0.98	0.89	0.72	1.00	1.00	0.92	0.75	1.00	1.00	0.93	0.75
	ΔT	25	24	23	20	25	25	23	20	25	25	23	20	25	25	23	20	24	24	23	20	22	22	22	19
85	kW	1.25	1.28	1.32	1.36	1.35	1.38	1.42	1.47	1.44	1.47	1.52	1.57	1.51	1.55	1.60	1.65	1.58	1.61	1.67	1.73	1.63	1.67	1.73	1.79
	Amps	5.6	5.7	5.8	6.0	6.0	6.1	6.3	6.5	6.4	6.6	6.8	7.0	6.8	7.0	7.2	7.4	7.2	7.4	7.6	7.9	7.6	7.8	8.0	8.3
	Hi PR	220	237	250	261	247	266	281	293	281	302	319	333	320	344	364	379	360	387	409	427	398	428	452	471
	Lo PR	110	118	128	137	117	124	136	144	121	129	141	150	127	136	148	158	134	142	155	165	138	147	160	171
	MBh	16.1	16.4	17.2	18.3	15.7	16.0	16.8	17.9	15.3	15.6	16.4	17.5	15.0	15.3	16.0	17.0	14.2	14.5	15.2	16.2	13.2	13.4	14.1	15.0
	S/T	0.89	0.86	0.78	0.63	0.93	0.89	0.81	0.65	0.95	0.92	0.83	0.67	0.98	0.95	0.85	0.69	1.00	0.98	0.89	0.72	1.00	0.99	0.89	0.72
	ΔT	25	25	23	20	25	25	24	21	26	25	24	21	26	25	24	21	25	25	24	21	23	23	22	19
	kW	1.22	1.24	1.28	1.33	1.31	1.34	1.39	1.43	1.40	1.43	1.48	1.53	1.47	1.51	1.56	1.61	1.54	1.57	1.63	1.68	1.59	1.63	1.68	1.74
	Amps	5.4	5.5	5.7	5.9	5.8	5.9	6.1	6.3	6.3	6.4	6.6	6.8	6.6	6.8	7.0	7.2	7.0	7.2	7.4	7.7	7.4	7.6	7.8	8.1
	Hi PR	214	230	243	253	240	258	272	284	273	293	310	323	310	334	353	368	349	376	397	414	386	415	438	457
Lo PR	107	114	124	133	113	120	131	140	118	125	137	146	124	131	144	153	130	138	150	160	134	143	156	166	

IDB: Entering Indoor Dry Bulb Temperature
 High and low pressures are measured at the liquid and suction service valves.
 Shaded area reflects AHR1 (TVA) conditions
 kW= Total system power
 Amps = outdoor unit amps (compressor + fan)

EXPANDED COOLING DATA — ASZ130241A* / ARUF182416**

IDB	AIRFLOW	OUTDOOR AMBIENT TEMPERATURE																							
		65°F				75°F				85°F				95°F				105°F				115°F			
		59	63	67	71	59	63	67	71	59	63	67	71	59	63	67	71	59	63	67	71	59	63	67	71
70	MBh	22.5	23.4	25.6	-	22.0	22.8	25.0	-	21.5	22.3	24.4	-	21.0	21.7	23.8	-	19.9	20.6	22.6	-	18.4	19.1	21.0	-
	S/T	0.74	0.62	0.43	-	0.77	0.64	0.45	-	0.79	0.66	0.46	-	0.81	0.68	0.47	-	0.85	0.71	0.49	-	0.85	0.71	0.49	-
	ΔT	17	14	11	-	17	15	11	-	17	15	11	-	17	15	11	-	17	15	11	-	16	14	10	-
	kW	1.64	1.67	1.73	-	1.76	1.80	1.86	-	1.87	1.91	1.97	-	1.97	2.01	2.07	-	2.05	2.09	2.16	-	2.12	2.16	2.23	-
	Amps	6.0	6.1	6.3	-	6.5	6.6	6.9	-	7.0	7.2	7.5	-	7.5	7.7	8.0	-	8.0	8.2	8.5	-	8.5	8.7	9.0	-
	HI PR	228	245	259	-	256	275	290	-	291	313	330	-	331	356	376	-	372	401	423	-	411	443	468	-
	Lo PR	106	112	123	-	112	119	130	-	116	123	135	-	122	130	142	-	128	136	148	-	132	141	153	-
	MBh	21.9	22.7	24.8	-	21.4	22.2	24.3	-	20.9	21.6	23.7	-	20.4	21.1	23.1	-	19.3	20.0	22.0	-	17.9	18.6	20.3	-
	S/T	0.71	0.59	0.41	-	0.73	0.61	0.42	-	0.75	0.63	0.44	-	0.78	0.65	0.45	-	0.81	0.67	0.47	-	0.81	0.68	0.47	-
	ΔT	17	15	11	-	18	15	12	-	18	15	12	-	18	15	12	-	17	15	11	-	16	14	11	-
kW	1.63	1.66	1.71	-	1.75	1.79	1.84	-	1.86	1.90	1.96	-	1.95	1.99	2.06	-	2.03	2.07	2.14	-	2.10	2.15	2.22	-	
Amps	5.9	6.1	6.3	-	6.4	6.6	6.8	-	7.0	7.1	7.4	-	7.5	7.6	7.9	-	7.9	8.1	8.4	-	8.4	8.6	8.9	-	
HI PR	225	243	256	-	253	272	287	-	288	310	327	-	328	353	372	-	369	397	419	-	407	438	463	-	
Lo PR	105	111	122	-	111	118	128	-	115	122	133	-	121	128	140	-	126	135	147	-	131	139	152	-	
MBh	20.2	20.9	22.9	-	19.7	20.4	22.4	-	19.3	20.0	21.9	-	18.8	19.5	21.3	-	17.8	18.5	20.3	-	16.5	17.1	18.8	-	
S/T	0.68	0.57	0.39	-	0.71	0.59	0.41	-	0.73	0.61	0.42	-	0.75	0.63	0.43	-	0.78	0.65	0.45	-	0.78	0.65	0.45	-	
ΔT	18	15	12	-	18	15	12	-	18	15	12	-	18	16	12	-	18	15	12	-	17	14	11	-	
kW	1.59	1.62	1.67	-	1.71	1.74	1.80	-	1.81	1.85	1.91	-	1.90	1.94	2.01	-	1.98	2.02	2.09	-	2.05	2.09	2.16	-	
Amps	5.8	5.9	6.1	-	6.2	6.4	6.6	-	6.8	7.0	7.2	-	7.3	7.4	7.7	-	7.7	7.9	8.2	-	8.2	8.4	8.7	-	
HI PR	219	235	249	-	245	264	279	-	279	300	317	-	318	342	361	-	358	385	406	-	395	425	449	-	
Lo PR	101	108	118	-	107	114	125	-	111	119	129	-	117	125	136	-	123	130	142	-	127	135	147	-	

75	MBh	22.92	23.60	25.54	27.41	22.39	23.05	24.95	26.78	21.85	22.50	24.36	26.14	21.32	21.95	23.76	25.50	20.25	20.85	22.57	24.23	18.76	19.32	20.91	22.44
	S/T	0.84	0.75	0.57	0.37	0.87	0.78	0.59	0.38	0.90	0.80	0.61	0.39	0.93	0.83	0.63	0.40	0.96	0.86	0.65	0.42	0.97	0.87	0.66	0.42
	ΔT	19	18	15	10	20	18	15	10	20	18	15	10	20	18	15	10	19	18	15	10	18	17	14	9
	kW	1.65	1.69	1.74	1.79	1.78	1.81	1.87	1.93	1.89	1.93	1.99	2.05	1.98	2.02	2.09	2.16	2.06	2.11	2.18	2.25	2.13	2.18	2.25	2.33
	Amps	6.0	6.2	6.4	6.6	6.5	6.7	6.9	7.2	7.1	7.3	7.5	7.8	7.6	7.8	8.0	8.4	8.1	8.3	8.6	8.9	8.6	8.8	9.1	9.4
	HI PR	230	248	261	273	258	278	293	306	294	316	334	348	334	360	380	396	376	405	427	446	416	447	472	493
	Lo PR	107	114	124	132	113	120	131	139	117	125	136	145	123	131	143	152	129	137	150	160	133	142	155	165
	MBh	22.3	22.9	24.8	26.6	21.7	22.4	24.2	26.0	21.2	21.8	23.6	25.4	20.7	21.3	23.1	24.8	19.7	20.2	21.9	23.5	18.2	18.8	20.3	21.8
	S/T	0.80	0.72	0.54	0.35	0.83	0.75	0.56	0.36	0.86	0.76	0.58	0.37	0.88	0.79	0.60	0.38	0.92	0.82	0.62	0.40	0.92	0.83	0.63	0.40
	ΔT	20	18	15	10	20	19	15	11	20	19	15	11	20	19	15	11	20	19	15	11	19	17	14	10
kW	1.64	1.67	1.73	1.78	1.76	1.80	1.86	1.92	1.87	1.91	1.97	2.03	1.97	2.01	2.07	2.14	2.05	2.09	2.16	2.23	2.12	2.16	2.23	2.31	
Amps	6.0	6.1	6.3	6.6	6.5	6.6	6.9	7.1	7.0	7.2	7.5	7.7	7.5	7.7	8.0	8.3	8.0	8.2	8.5	8.8	8.5	8.7	9.0	9.3	
HI PR	228	245	259	270	256	275	290	303	291	313	330	345	331	356	376	392	372	401	423	441	412	443	468	488	
Lo PR	106	112	123	131	112	119	130	138	116	123	135	144	122	130	142	151	128	136	148	158	132	141	153	163	
MBh	20.5	21.1	22.9	24.6	20.1	20.7	22.4	24.0	19.6	20.2	21.8	23.4	19.1	19.6	21.3	22.9	18.2	18.7	20.2	21.7	16.8	17.3	18.7	20.1	
S/T	0.78	0.69	0.53	0.34	0.80	0.72	0.54	0.35	0.82	0.74	0.56	0.36	0.85	0.76	0.58	0.37	0.88	0.79	0.60	0.38	0.89	0.80	0.60	0.39	
ΔT	20	19	15	11	21	19	16	11	21	19	16	11	21	19	16	11	21	19	15	11	19	18	14	10	
kW	1.60	1.64	1.69	1.74	1.72	1.76	1.81	1.87	1.83	1.86	1.92	1.99	1.92	1.96	2.02	2.09	2.00	2.04	2.11	2.17	2.06	2.11	2.18	2.25	
Amps	5.8	6.0	6.2	6.4	6.3	6.5	6.7	6.9	6.9	7.0	7.3	7.5	7.3	7.5	7.8	8.0	7.8	8.0	8.3	8.6	8.3	8.5	8.8	9.1	
HI PR	221	238	251	262	248	267	282	294	282	303	320	334	321	346	365	381	361	389	411	428	399	430	454	473	
Lo PR	103	109	119	127	108	115	126	134	113	120	131	139	118	126	137	146	124	132	144	153	128	136	149	159	

IDB: Entering Indoor Dry Bulb Temperature
 High and low pressures are measured at the liquid and suction service valves.
 Shaded area reflects ACCA (TVA) conditions
 Amps = outdoor unit amps (compressor + fan)
 kW= Total system power

EXPANDED COOLING DATA — ASZ130241A* / ARUF182416** (CONT.)

IDB	AIRFLOW	OUTDOOR AMBIENT TEMPERATURE																							
		65°F				75°F				85°F				95°F				105°F				115°F			
		59	63	67	71	59	63	67	71	59	63	67	71	59	63	67	71	59	63	67	71	59	63	67	71
80	MBh	23.33	23.84	25.47	27.22	22.79	23.28	24.87	26.59	22.24	22.73	24.28	25.96	21.70	22.17	23.69	25.32	20.62	21.07	22.51	24.06	19.10	19.51	20.85	22.29
	S/T	0.93	0.87	0.71	0.53	0.96	0.90	0.73	0.55	1.00	0.92	0.75	0.56	1.00	0.95	0.77	0.58	1.00	1.00	0.80	0.60	1.00	1.00	0.81	0.61
	ΔT	22	21	18	14	22	21	18	15	22	21	18	15	22	21	18	15	22	21	18	14	19	19	17	13
	kW	1.67	1.70	1.75	1.81	1.79	1.83	1.89	1.95	1.90	1.94	2.00	2.07	2.00	2.04	2.11	2.18	2.08	2.13	2.20	2.27	2.15	2.20	2.27	2.35
	Amps	6.1	6.3	6.5	6.7	6.6	6.8	7.0	7.2	7.2	7.4	7.6	7.9	7.7	7.9	8.1	8.4	8.2	8.4	8.7	9.0	8.7	8.9	9.2	9.5
	Hi PR	232	250	264	275	261	281	296	309	297	319	337	351	338	363	384	400	380	409	432	450	420	452	477	498
	Lo PR	108	115	125	133	114	121	132	141	118	126	137	146	124	132	144	154	130	139	151	161	135	143	157	167
	MBh	22.6	23.1	24.7	26.4	22.1	22.6	24.2	25.8	21.6	22.1	23.6	25.2	21.1	21.5	23.0	24.6	20.0	20.5	21.9	23.4	18.5	18.9	20.2	21.6
	S/T	0.88	0.83	0.67	0.50	0.91	0.86	0.70	0.52	0.94	0.88	0.72	0.54	0.97	0.91	0.74	0.55	1.00	0.94	0.77	0.57	1.00	0.95	0.77	0.58
	ΔT	22	21	19	15	23	22	19	15	23	22	19	15	23	22	19	15	22	22	19	15	21	20	18	14
kW	1.65	1.69	1.74	1.79	1.78	1.81	1.87	1.93	1.89	1.93	1.99	2.05	1.98	2.03	2.09	2.16	2.06	2.11	2.18	2.25	2.13	2.18	2.25	2.33	
Amps	6.0	6.2	6.4	6.6	6.5	6.7	6.9	7.2	7.1	7.3	7.5	7.8	7.6	7.8	8.1	8.4	8.1	8.3	8.6	8.9	8.6	8.8	9.1	9.4	
Hi PR	230	248	261	273	258	278	293	306	294	316	334	348	334	360	380	396	376	405	428	446	416	447	472	493	
Lo PR	107	114	124	132	113	120	131	140	117	125	136	145	123	131	143	152	129	137	150	160	133	142	155	165	
MBh	20.9	21.4	22.8	24.4	20.4	20.9	22.3	23.8	19.9	20.4	21.8	23.3	19.4	19.9	21.2	22.7	18.5	18.9	20.2	21.6	17.1	17.5	18.7	20.0	
S/T	0.85	0.80	0.65	0.49	0.88	0.83	0.67	0.50	0.90	0.85	0.69	0.52	0.93	0.88	0.71	0.53	0.97	0.91	0.74	0.55	0.98	0.92	0.75	0.56	
ΔT	23	22	19	15	23	22	19	15	23	22	19	15	23	22	19	15	23	22	19	15	21	21	18	14	
kW	1.62	1.65	1.70	1.75	1.74	1.77	1.83	1.88	1.84	1.88	1.94	2.00	1.93	1.98	2.04	2.11	2.01	2.06	2.12	2.19	2.08	2.13	2.20	2.27	
Amps	5.9	6.0	6.2	6.5	6.4	6.5	6.7	7.0	6.9	7.1	7.3	7.6	7.4	7.6	7.8	8.1	7.9	8.1	8.3	8.7	8.3	8.5	8.8	9.2	
Hi PR	223	240	254	265	250	269	285	297	285	306	324	338	324	349	369	384	365	393	415	433	403	434	458	478	
Lo PR	104	110	120	128	109	116	127	135	114	121	132	141	119	127	139	148	125	133	145	155	129	138	150	160	

85	MBh	23.74	24.19	25.34	27.03	23.18	23.63	24.75	26.40	22.63	23.07	24.16	25.78	22.08	22.51	23.57	25.15	20.98	21.38	22.39	23.89	19.43	19.81	20.74	22.13
	S/T	0.97	0.94	0.84	0.69	1.00	0.97	0.88	0.71	1.00	0.99	0.90	0.73	1.00	1.00	0.93	0.75	1.00	1.00	0.96	0.78	1.00	1.00	0.97	0.79
	ΔT	23	23	21	18	23	23	22	19	23	23	22	19	22	22	22	19	21	21	21	19	19	20	20	17
	kW	1.68	1.71	1.77	1.82	1.81	1.84	1.90	1.96	1.92	1.96	2.02	2.09	2.01	2.06	2.12	2.19	2.10	2.14	2.21	2.29	2.17	2.22	2.29	2.37
	Amps	6.2	6.3	6.5	6.8	6.7	6.8	7.0	7.3	7.2	7.4	7.7	8.0	7.7	7.9	8.2	8.5	8.2	8.4	8.7	9.1	8.7	9.0	9.3	9.6
	Hi PR	235	253	267	278	263	283	299	312	300	322	340	355	341	367	388	404	384	413	436	455	424	456	482	503
	Lo PR	109	116	126	135	115	122	134	142	120	127	139	148	126	134	146	155	132	140	153	163	136	145	158	168
	MBh	23.0	23.5	24.6	26.2	22.5	22.9	24.0	25.6	22.0	22.4	23.5	25.0	21.4	21.9	22.9	24.4	20.4	20.8	21.7	23.2	18.9	19.2	20.1	21.5
	S/T	0.93	0.89	0.81	0.65	0.96	0.93	0.84	0.68	0.98	0.95	0.86	0.69	1.00	0.98	0.88	0.72	1.00	1.00	0.92	0.74	1.00	1.00	0.93	0.75
	ΔT	24	24	22	19	24	24	23	20	24	24	23	20	24	24	23	20	23	23	22	19	21	22	21	18
kW	1.67	1.70	1.75	1.81	1.79	1.83	1.89	1.95	1.90	1.94	2.00	2.07	2.00	2.04	2.11	2.18	2.08	2.13	2.20	2.27	2.15	2.20	2.27	2.35	
Amps	6.1	6.3	6.5	6.7	6.6	6.8	7.0	7.2	7.2	7.4	7.6	7.9	7.7	7.9	8.1	8.4	8.2	8.4	8.7	9.0	8.7	8.9	9.2	9.5	
Hi PR	232	250	264	275	261	281	296	309	297	319	337	351	338	363	384	400	380	409	432	450	420	452	477	498	
Lo PR	108	115	125	133	114	121	132	141	118	126	137	146	124	132	144	154	130	139	151	161	135	143	157	167	
MBh	21.3	21.7	22.7	24.2	20.8	21.2	22.2	23.7	20.3	20.7	21.7	23.1	19.8	20.2	21.1	22.5	18.8	19.2	20.1	21.4	17.4	17.7	18.6	19.8	
S/T	0.89	0.86	0.78	0.63	0.92	0.89	0.81	0.65	0.95	0.91	0.83	0.67	0.98	0.94	0.85	0.69	1.00	0.98	0.88	0.72	1.00	0.99	0.89	0.72	
ΔT	24	24	23	20	25	24	23	20	25	24	23	20	25	24	23	20	24	24	23	20	22	22	21	18	
kW	1.63	1.66	1.71	1.77	1.75	1.79	1.84	1.90	1.86	1.89	1.95	2.02	1.95	1.99	2.06	2.12	2.03	2.07	2.14	2.21	2.10	2.14	2.21	2.29	
Amps	5.9	6.1	6.3	6.5	6.4	6.6	6.8	7.0	7.0	7.1	7.4	7.7	7.5	7.6	7.9	8.2	7.9	8.1	8.4	8.7	8.4	8.6	8.9	9.3	
Hi PR	225	243	256	267	253	272	287	300	288	310	327	341	328	353	372	388	369	397	419	437	407	438	463	483	
Lo PR	105	111	121	129	110	118	128	137	115	122	133	142	121	128	140	149	126	134	147	156	131	139	152	162	

IDB: Entering Indoor Dry Bulb Temperature
 High and low pressures are measured at the liquid and suction service valves.
 Shaded area reflects AHRI (TVA) conditions
 kW=Total system power
 Amps = outdoor unit amps (compressor + fan)

EXPANDED COOLING DATA — ASZ130301A* / AR*F303016**

IDB	AIRFLOW	OUTDOOR AMBIENT TEMPERATURE												ENTERING INDOOR WET BULB TEMPERATURE											
		65°F				75°F				85°F				95°F				105°F				115°F			
		59	63	67	71	59	63	67	71	59	63	67	71	59	63	67	71	59	63	67	71	59	63	67	71
70	MBh	27.4	28.4	31.1	-	26.8	27.8	30.4	-	26.1	27.1	29.7	-	25.5	26.4	29.0	-	24.2	25.1	27.5	-	22.4	23.3	25.5	-
	S/T	0.74	0.62	0.43	-	0.77	0.64	0.44	-	0.79	0.66	0.45	-	0.81	0.68	0.47	-	0.84	0.70	0.49	-	0.85	0.71	0.49	-
	ΔT	17	14	11	-	17	15	11	-	17	15	11	-	17	15	11	-	17	15	11	-	16	14	10	-
	kW	2.03	2.07	2.13	-	2.18	2.22	2.29	-	2.31	2.36	2.43	-	2.42	2.47	2.55	-	2.52	2.58	2.66	-	2.61	2.66	2.75	-
	Amps	7.3	7.5	7.7	-	7.9	8.1	8.3	-	8.6	8.8	9.1	-	9.2	9.4	9.7	-	9.8	10.0	10.3	-	10.3	10.6	11.0	-
	Hi PR	228	246	259	-	256	276	291	-	291	313	331	-	332	357	377	-	373	402	424	-	412	444	469	-
	Lo PR	106	113	123	-	112	119	130	-	116	124	135	-	122	130	142	-	128	136	149	-	133	141	154	-
	MBh	27.0	28.0	30.7	-	26.4	27.4	30.0	-	25.8	26.7	29.3	-	25.1	26.1	28.5	-	23.9	24.7	27.1	-	22.1	22.9	25.1	-
	S/T	0.71	0.59	0.41	-	0.73	0.61	0.42	-	0.75	0.63	0.44	-	0.78	0.65	0.45	-	0.81	0.67	0.47	-	0.81	0.68	0.47	-
	ΔT	18	15	12	-	18	15	12	-	18	15	12	-	18	16	12	-	18	15	12	-	17	14	11	-
kW	2.02	2.06	2.12	-	2.17	2.21	2.28	-	2.30	2.34	2.42	-	2.41	2.46	2.54	-	2.51	2.56	2.64	-	2.59	2.65	2.73	-	
Amps	7.2	7.4	7.7	-	7.8	8.0	8.3	-	8.5	8.7	9.0	-	9.1	9.3	9.6	-	9.7	9.9	10.3	-	10.3	10.5	10.9	-	
Hi PR	227	244	258	-	254	274	289	-	289	311	329	-	329	355	374	-	371	399	421	-	409	441	465	-	
Lo PR	105	112	122	-	111	118	129	-	116	123	134	-	122	129	141	-	127	135	148	-	132	140	153	-	
MBh	25.7	26.6	29.1	-	25.1	26.0	28.5	-	24.5	25.4	27.8	-	23.9	24.7	27.1	-	22.7	23.5	25.8	-	21.0	21.8	23.9	-	
S/T	0.68	0.57	0.39	-	0.70	0.59	0.41	-	0.72	0.60	0.42	-	0.74	0.62	0.43	-	0.77	0.64	0.45	-	0.78	0.65	0.45	-	
ΔT	18	16	12	-	18	16	12	-	18	16	12	-	19	16	12	-	18	16	12	-	17	15	11	-	
kW	1.99	2.03	2.09	-	2.13	2.18	2.24	-	2.26	2.31	2.38	-	2.37	2.42	2.50	-	2.47	2.52	2.60	-	2.55	2.60	2.69	-	
Amps	7.1	7.3	7.5	-	7.7	7.9	8.1	-	8.3	8.6	8.8	-	8.9	9.1	9.5	-	9.5	9.7	10.1	-	10.1	10.3	10.7	-	
Hi PR	222	239	252	-	249	268	283	-	283	305	322	-	323	347	367	-	363	391	413	-	401	432	456	-	
Lo PR	103	110	120	-	109	116	127	-	113	121	132	-	119	127	138	-	125	133	145	-	129	137	150	-	
75	MBh	27.89	28.71	31.08	33.36	27.24	28.05	30.36	32.58	26.59	27.38	29.64	31.81	25.94	26.71	28.91	31.03	24.65	25.38	27.47	29.48	22.83	23.51	25.44	27.31
	S/T	0.84	0.75	0.57	0.37	0.87	0.78	0.59	0.38	0.89	0.80	0.60	0.39	0.92	0.82	0.62	0.40	0.96	0.86	0.65	0.42	0.96	0.86	0.65	0.42
	ΔT	19	18	15	10	20	18	15	10	20	18	15	10	20	18	15	10	19	18	15	10	18	17	14	9
	kW	2.05	2.09	2.15	2.22	2.20	2.24	2.31	2.38	2.33	2.38	2.45	2.53	2.44	2.49	2.57	2.66	2.54	2.60	2.68	2.77	2.63	2.68	2.77	2.86
	Amps	7.3	7.5	7.8	8.1	7.9	8.1	8.4	8.7	8.6	8.9	9.2	9.5	9.2	9.5	9.8	10.2	9.8	10.1	10.4	10.8	10.4	10.7	11.1	11.5
	Hi PR	231	248	262	273	259	278	294	307	294	317	334	349	335	361	381	397	377	406	428	447	417	448	473	494
	Lo PR	107	114	124	133	113	120	131	140	118	125	137	146	124	131	144	153	130	138	150	160	134	143	156	166
	MBh	27.5	28.3	30.6	32.9	26.8	27.6	29.9	32.1	26.2	27.0	29.2	31.3	25.6	26.3	28.5	30.6	24.3	25.0	27.1	29.0	22.5	23.2	25.1	26.9
	S/T	0.80	0.72	0.54	0.35	0.83	0.75	0.56	0.36	0.86	0.76	0.58	0.37	0.88	0.79	0.60	0.38	0.92	0.82	0.62	0.40	0.92	0.83	0.63	0.40
	ΔT	20	19	15	11	21	19	16	11	21	19	16	11	21	19	16	11	20	19	15	11	19	18	14	10
kW	2.03	2.08	2.14	2.20	2.18	2.23	2.30	2.37	2.31	2.36	2.44	2.51	2.43	2.48	2.56	2.64	2.53	2.58	2.66	2.75	2.61	2.67	2.75	2.84	
Amps	7.3	7.5	7.7	8.0	7.9	8.1	8.4	8.7	8.6	8.8	9.1	9.4	9.2	9.4	9.7	10.1	9.8	10.0	10.4	10.8	10.4	10.6	11.0	11.4	
Hi PR	229	246	260	271	257	276	292	305	292	314	332	346	333	358	378	394	374	403	425	444	414	445	470	490	
Lo PR	106	113	124	132	112	120	131	139	117	124	136	145	123	131	143	152	129	137	149	159	133	142	155	165	
MBh	26.1	26.9	29.1	31.2	25.5	26.3	28.4	30.5	24.9	25.6	27.7	29.8	24.3	25.0	27.1	29.0	23.1	23.8	25.7	27.6	21.4	22.0	23.8	25.6	
S/T	0.77	0.69	0.52	0.34	0.80	0.71	0.54	0.35	0.82	0.73	0.55	0.36	0.85	0.76	0.57	0.37	0.88	0.78	0.59	0.38	0.88	0.79	0.60	0.39	
ΔT	21	19	16	11	21	20	16	11	21	20	16	11	21	20	16	11	21	19	16	11	20	18	15	10	
kW	2.00	2.04	2.11	2.17	2.15	2.19	2.26	2.33	2.28	2.33	2.40	2.47	2.39	2.44	2.52	2.60	2.49	2.54	2.62	2.71	2.57	2.63	2.71	2.80	
Amps	7.2	7.3	7.6	7.9	7.8	7.9	8.2	8.5	8.4	8.6	8.9	9.3	9.0	9.2	9.5	9.9	9.6	9.8	10.2	10.6	10.2	10.4	10.8	11.2	
Hi PR	224	241	255	266	252	271	286	298	286	308	325	339	326	351	371	387	367	395	417	435	405	436	461	480	
Lo PR	104	111	121	129	110	117	128	136	115	122	133	142	120	128	140	149	126	134	146	156	130	139	151	161	

IDB: Entering Indoor Dry Bulb Temperature
 High and low pressures are measured at the liquid and suction service valves.
 Shaded area reflects ACCA (TVA) conditions
 kW=Total system power
 Amps = outdoor unit amps (compressor + fan)

EXPANDED COOLING DATA — ASZ130301A* / AR*F303016** (CONT.)

IDB	AIRFLOW	OUTDOOR AMBIENT TEMPERATURE												ENTERING INDOOR WET BULB TEMPERATURE											
		65°F				75°F				85°F				95°F				105°F				115°F			
		59	63	67	71	59	63	67	71	59	63	67	71	59	63	67	71	59	63	67	71	59	63	67	71
80	1118	28.38	29.00	30.99	33.13	27.72	28.33	30.27	32.36	27.06	27.66	29.55	31.59	26.40	26.98	28.83	30.81	25.08	25.63	27.38	29.27	23.24	23.74	25.37	27.12
	S/T	0.92	0.86	0.70	0.53	0.96	0.90	0.73	0.54	0.98	0.92	0.75	0.56	1.00	0.95	0.77	0.58	1.00	0.98	0.80	0.60	1.00	1.00	0.81	0.60
	ΔT	22	21	18	14	22	21	18	15	22	21	18	15	22	21	18	15	21	21	18	14	19	20	17	13
	kW	2.06	2.10	2.17	2.23	2.21	2.26	2.33	2.40	2.35	2.39	2.47	2.56	2.46	2.52	2.59	2.68	2.56	2.62	2.70	2.79	2.65	2.71	2.79	2.88
	Amps	7.4	7.6	7.8	8.1	8.0	8.2	8.5	8.8	8.7	8.9	9.2	9.6	9.3	9.6	9.9	10.3	9.9	10.2	10.5	10.9	10.5	10.8	11.2	11.6
	HI PR	233	251	265	276	261	281	297	310	297	320	338	352	339	364	385	401	381	410	433	451	421	453	478	499
	Lo PR	108	115	126	134	114	122	133	141	119	126	138	147	125	133	145	154	131	139	152	162	135	144	157	167
	MBh	28.0	28.6	30.5	32.6	27.3	27.9	29.8	31.9	26.7	27.2	29.1	31.1	26.0	26.6	28.4	30.4	24.7	25.3	27.0	28.8	22.9	23.4	25.0	26.7
	S/T	0.88	0.83	0.67	0.50	0.91	0.86	0.70	0.52	0.94	0.88	0.72	0.54	0.97	0.91	0.74	0.55	1.00	0.94	0.77	0.57	1.00	0.95	0.77	0.58
	ΔT	23	22	19	15	23	22	19	15	23	22	19	15	23	22	19	15	23	22	19	15	21	20	18	14
	kW	2.05	2.09	2.15	2.22	2.20	2.25	2.31	2.39	2.33	2.38	2.46	2.53	2.45	2.50	2.58	2.66	2.55	2.60	2.69	2.77	2.63	2.69	2.78	2.87
	Amps	7.4	7.5	7.8	8.1	8.0	8.2	8.4	8.8	8.7	8.9	9.2	9.5	9.3	9.5	9.8	10.2	9.9	10.1	10.5	10.9	10.5	10.7	11.1	11.5
HI PR	231	249	263	274	260	279	295	308	295	318	335	350	336	362	382	398	378	407	430	448	418	450	475	495	
Lo PR	107	114	125	133	114	121	132	140	118	126	137	146	124	132	144	153	130	138	151	161	134	143	156	166	
MBh	26.6	27.1	29.0	31.0	25.9	26.5	28.3	30.3	25.3	25.9	27.7	29.6	24.7	25.3	27.0	28.8	23.5	24.0	25.6	27.4	21.7	22.2	23.7	25.4	
S/T	0.85	0.79	0.65	0.48	0.88	0.82	0.67	0.50	0.90	0.84	0.69	0.51	0.93	0.87	0.71	0.53	0.96	0.90	0.73	0.55	0.97	0.91	0.74	0.55	
ΔT	23	22	19	16	24	23	20	16	24	23	20	16	24	23	20	16	24	23	20	16	22	21	18	15	
kW	2.02	2.06	2.12	2.19	2.17	2.21	2.28	2.35	2.30	2.34	2.42	2.49	2.41	2.46	2.54	2.62	2.51	2.56	2.64	2.73	2.59	2.65	2.73	2.82	
Amps	7.2	7.4	7.7	7.9	7.8	8.0	8.3	8.6	8.5	8.7	9.0	9.4	9.1	9.3	9.6	10.0	9.7	9.9	10.3	10.7	10.3	10.5	10.9	11.3	
HI PR	227	244	258	269	254	274	289	301	289	311	329	343	329	355	374	390	371	399	421	439	409	441	465	485	
Lo PR	105	112	122	130	111	118	129	138	116	123	134	143	122	129	141	150	127	135	148	158	132	140	153	163	
85	1118	28.88	29.44	30.83	32.89	28.21	28.76	30.12	32.13	27.54	28.07	29.40	31.36	26.87	27.39	28.68	30.60	25.52	26.02	27.25	29.07	23.64	24.10	25.24	26.93
	S/T	0.97	0.93	0.84	0.68	1.00	0.97	0.87	0.71	1.00	0.99	0.89	0.73	1.00	1.00	0.92	0.75	1.00	1.00	0.96	0.78	1.00	1.00	0.97	0.78
	ΔT	23	23	21	18	23	23	22	19	23	23	22	19	22	23	22	19	21	21	21	19	19	20	20	17
	kW	2.08	2.12	2.18	2.25	2.23	2.28	2.35	2.42	2.36	2.41	2.49	2.57	2.48	2.54	2.62	2.70	2.58	2.64	2.72	2.81	2.67	2.73	2.82	2.91
	Amps	7.5	7.7	7.9	8.2	8.1	8.3	8.6	8.9	8.8	9.0	9.3	9.7	9.4	9.7	10.0	10.4	10.0	10.3	10.6	11.0	10.6	10.9	11.3	11.7
	HI PR	235	253	267	279	264	284	300	313	300	323	341	356	342	368	389	405	385	414	437	456	425	457	483	504
	Lo PR	109	116	127	135	116	123	134	143	120	128	139	148	126	134	146	156	132	141	153	163	137	145	159	169
	MBh	28.5	29.0	30.4	32.4	27.8	28.3	29.7	31.7	27.1	27.7	29.0	30.9	26.5	27.0	28.3	30.1	25.1	25.6	26.8	28.6	23.3	23.7	24.9	26.5
	S/T	0.93	0.89	0.81	0.65	0.96	0.93	0.84	0.68	0.98	0.95	0.86	0.69	1.00	0.98	0.88	0.72	1.00	1.00	0.92	0.74	1.00	1.00	0.93	0.75
	ΔT	24	24	23	19	25	24	23	20	25	24	23	20	24	24	23	20	23	24	23	20	21	22	21	18
	kW	2.07	2.11	2.17	2.24	2.22	2.26	2.33	2.41	2.35	2.40	2.47	2.55	2.47	2.52	2.60	2.68	2.57	2.62	2.71	2.80	2.66	2.71	2.80	2.89
	Amps	7.4	7.6	7.9	8.2	8.0	8.2	8.5	8.8	8.7	9.0	9.3	9.6	9.4	9.6	9.9	10.3	10.0	10.2	10.6	11.0	10.6	10.8	11.2	11.6
HI PR	234	251	265	277	262	282	298	311	298	321	339	353	340	365	386	402	382	411	434	453	422	454	480	500	
Lo PR	109	116	126	134	115	122	133	142	119	127	138	147	125	133	145	155	131	140	152	162	136	144	158	168	
MBh	27.0	27.6	28.9	30.8	26.4	26.9	28.2	30.1	25.8	26.3	27.5	29.4	25.1	25.6	26.8	28.6	23.9	24.4	25.5	27.2	22.1	22.6	23.6	25.2	
S/T	0.89	0.86	0.77	0.63	0.92	0.89	0.80	0.65	0.94	0.91	0.82	0.67	0.97	0.94	0.85	0.69	1.00	0.97	0.88	0.71	1.00	0.98	0.89	0.72	
ΔT	25	25	23	20	25	25	23	20	25	25	24	20	25	25	24	20	25	25	23	20	23	23	22	19	
kW	2.03	2.08	2.14	2.20	2.18	2.23	2.30	2.37	2.31	2.36	2.44	2.51	2.43	2.48	2.56	2.64	2.53	2.58	2.66	2.75	2.61	2.67	2.75	2.84	
Amps	7.3	7.5	7.7	8.0	7.9	8.1	8.4	8.7	8.6	8.8	9.1	9.4	9.2	9.4	9.7	10.1	9.8	10.0	10.4	10.8	10.4	10.6	11.0	11.4	
HI PR	229	246	260	271	257	276	292	304	292	314	332	346	333	358	378	394	374	403	425	444	414	445	470	490	
Lo PR	106	113	124	132	112	120	131	139	117	124	136	145	123	131	143	152	129	137	149	159	133	142	155	165	

IDB: Entering Indoor Dry Bulb Temperature
 High and low pressures are measured at the liquid and suction service valves.
 Shaded area reflects AHRH (TVA) conditions
 kW=Total system power
 Amps = outdoor unit amps (compressor + fan)

EXPANDED COOLING DATA — ASZ130361A* / AR*F364216**

IDB	AIRFLOW	OUTDOOR AMBIENT TEMPERATURE																							
		65°F				75°F				85°F				95°F				105°F				115°F			
		59	63	67	71	59	63	67	71	59	63	67	71	59	63	67	71	59	63	67	71	59	63	67	71
70	MBh	33.8	35.0	38.4	-	33.0	34.2	37.5	-	32.2	33.4	36.6	-	31.4	32.6	35.7	-	29.9	31.0	33.9	-	27.7	28.7	31.4	-
	S/T	0.74	0.62	0.43	-	0.77	0.64	0.44	-	0.79	0.66	0.46	-	0.81	0.68	0.47	-	0.84	0.70	0.49	-	0.85	0.71	0.49	-
	ΔT	16	14	11	-	16	14	11	-	16	14	11	-	16	14	11	-	16	14	11	-	15	13	10	-
	kW	2.48	2.53	2.61	-	2.67	2.72	2.81	-	2.83	2.89	2.99	-	2.98	3.05	3.15	-	3.11	3.17	3.28	-	3.21	3.28	3.39	-
	Amps	9.1	9.3	9.6	-	9.9	10.1	10.4	-	10.7	11.0	11.3	-	11.5	11.7	12.1	-	12.2	12.5	12.9	-	12.9	13.3	13.7	-
	Hi PR	231	249	263	-	259	279	295	-	295	318	335	-	336	362	382	-	378	407	430	-	418	450	475	-
	Lo PR	105	112	122	-	111	118	129	-	116	123	134	-	122	129	141	-	127	135	148	-	132	140	153	-
	MBh	33.3	34.5	37.8	-	32.5	33.7	36.9	-	31.7	32.9	36.1	-	31.0	32.1	35.2	-	29.4	30.5	33.4	-	27.3	28.3	31.0	-
	S/T	0.71	0.59	0.41	-	0.73	0.61	0.43	-	0.75	0.63	0.44	-	0.78	0.65	0.45	-	0.81	0.67	0.47	-	0.81	0.68	0.47	-
	ΔT	17	15	11	-	17	15	11	-	17	15	11	-	17	15	11	-	17	15	11	-	16	14	11	-
	kW	2.46	2.52	2.59	-	2.65	2.71	2.79	-	2.82	2.88	2.97	-	2.96	3.03	3.13	-	3.09	3.16	3.26	-	3.19	3.27	3.37	-
	Amps	9.1	9.3	9.6	-	9.8	10.0	10.4	-	10.7	10.9	11.3	-	11.4	11.7	12.1	-	12.1	12.4	12.8	-	12.9	13.2	13.6	-
Hi PR	230	247	261	-	258	277	293	-	293	315	333	-	334	359	379	-	375	404	427	-	415	446	471	-	
Lo PR	105	111	122	-	111	118	128	-	115	122	133	-	121	128	140	-	126	135	147	-	131	139	152	-	
MBh	31.6	32.8	35.9	-	30.9	32.0	35.1	-	30.2	31.3	34.3	-	29.4	30.5	33.4	-	28.0	29.0	31.7	-	25.9	26.8	29.4	-	
S/T	0.68	0.57	0.39	-	0.70	0.59	0.41	-	0.72	0.60	0.42	-	0.74	0.62	0.43	-	0.77	0.65	0.45	-	0.78	0.65	0.45	-	
ΔT	18	15	12	-	18	15	12	-	18	15	12	-	18	16	12	-	18	15	12	-	16	14	11	-	
kW	2.43	2.48	2.55	-	2.61	2.66	2.75	-	2.77	2.83	2.92	-	2.91	2.98	3.08	-	3.04	3.10	3.20	-	3.14	3.21	3.32	-	
Amps	8.9	9.1	9.4	-	9.6	9.9	10.2	-	10.5	10.7	11.1	-	11.2	11.5	11.8	-	11.9	12.2	12.6	-	12.6	12.9	13.4	-	
Hi PR	225	242	256	-	253	272	287	-	287	309	326	-	327	352	372	-	368	396	418	-	407	438	462	-	
Lo PR	103	109	119	-	108	115	126	-	113	120	131	-	118	126	137	-	124	132	144	-	128	136	149	-	
75	MBh	34.37	35.39	38.30	41.11	33.57	34.56	37.41	40.15	32.77	33.74	36.52	39.20	31.97	32.92	35.63	38.24	30.37	31.27	33.85	36.33	28.14	28.97	31.36	33.65
	S/T	0.84	0.75	0.57	0.37	0.87	0.78	0.59	0.38	0.89	0.80	0.61	0.39	0.92	0.83	0.62	0.40	0.96	0.86	0.65	0.42	0.97	0.86	0.65	0.42
	ΔT	19	17	14	10	19	17	14	10	19	17	14	10	19	18	14	10	19	17	14	10	18	16	13	9
	kW	2.50	2.55	2.63	2.71	2.69	2.75	2.83	2.93	2.86	2.92	3.01	3.11	3.01	3.07	3.17	3.28	3.13	3.20	3.31	3.42	3.24	3.31	3.42	3.54
	Amps	9.2	9.4	9.7	10.1	10.0	10.2	10.5	10.9	10.8	11.1	11.5	11.9	11.6	11.9	12.3	12.7	12.3	12.6	13.1	13.6	13.1	13.4	13.8	14.4
	Hi PR	234	251	265	277	262	282	298	311	298	321	339	353	340	365	386	402	382	411	434	453	422	454	480	500
	Lo PR	106	113	124	132	112	120	131	139	117	124	136	145	123	131	143	152	129	137	149	159	133	142	155	165
	MBh	33.9	34.9	37.7	40.5	33.1	34.1	36.9	39.6	32.3	33.2	36.0	38.6	31.5	32.4	35.1	37.7	29.9	30.8	33.3	35.8	27.7	28.5	30.9	33.2
	S/T	0.81	0.72	0.55	0.35	0.84	0.75	0.57	0.36	0.86	0.77	0.58	0.37	0.88	0.79	0.60	0.38	0.92	0.82	0.62	0.40	0.93	0.83	0.63	0.40
	ΔT	20	18	15	10	20	18	15	10	20	18	15	10	20	18	15	10	20	18	15	10	18	17	14	10
	kW	2.48	2.54	2.62	2.70	2.67	2.73	2.82	2.91	2.84	2.90	3.00	3.09	2.99	3.05	3.15	3.26	3.11	3.18	3.29	3.40	3.22	3.29	3.40	3.52
	Amps	9.1	9.4	9.7	10.0	9.9	10.1	10.5	10.9	10.8	11.0	11.4	11.8	11.5	11.8	12.2	12.6	12.2	12.5	13.0	13.5	13.0	13.3	13.7	14.3
Hi PR	232	250	264	275	260	280	296	308	296	319	336	351	337	363	383	400	379	408	431	450	419	451	476	497	
Lo PR	106	112	123	131	112	119	130	138	116	123	135	144	122	130	142	151	128	136	148	158	132	141	153	163	
MBh	32.2	33.1	35.9	38.5	31.4	32.4	35.0	37.6	30.7	31.6	34.2	36.7	29.9	30.81	33.3	35.8	28.4	29.3	31.7	34.0	26.3	27.1	29.3	31.5	
S/T	0.77	0.69	0.52	0.34	0.80	0.72	0.54	0.35	0.82	0.73	0.56	0.36	0.85	0.76	0.57	0.37	0.88	0.79	0.59	0.38	0.89	0.79	0.60	0.39	
ΔT	20	19	15	11	21	19	15	11	21	19	16	11	21	19	16	11	20	19	15	11	19	18	14	10	
kW	2.45	2.50	2.57	2.66	2.63	2.69	2.77	2.86	2.79	2.85	2.95	3.04	2.94	3.00	3.10	3.20	3.06	3.13	3.23	3.34	3.17	3.24	3.35	3.46	
Amps	9.0	9.2	9.5	9.9	9.7	9.9	10.3	10.7	10.6	10.8	11.2	11.6	11.3	11.6	11.9	12.4	12.0	12.3	12.7	13.2	12.7	13.0	13.5	14.0	
Hi PR	227	245	258	269	255	274	290	302	290	312	330	344	330	356	375	392	372	400	422	441	411	442	467	487	
Lo PR	104	110	120	128	109	116	127	135	114	121	132	141	119	127	139	148	125	133	145	155	129	138	150	160	

IDB: Entering Indoor Dry Bulb Temperature
 High and low pressures are measured at the liquid and suction service valves.
 Shaded area reflects ACCA (TVA) conditions
 kW=Total system power
 Amps = outdoor unit amps (compressor + fan)

EXPANDED COOLING DATA — ASZ130361A* / AR*F364216** (CONT.)

IDB	AIRFLOW	OUTDOOR AMBIENT TEMPERATURE																																																																						
		65°F				75°F				85°F				95°F				105°F				115°F																																																		
		59	63	67	71	59	63	67	71	59	63	67	71	59	63	67	71	59	63	67	71	59	63	67	71																																															
80	1425	MBh	34.98	35.75	38.19	40.82	34.17	34.91	37.30	39.88	33.35	34.08	36.41	38.93	32.54	33.25	35.53	37.98	30.91	31.59	33.75	36.08	28.64	29.26	31.26	33.42	S/T	0.92	0.87	0.70	0.53	0.96	0.90	0.73	0.55	0.98	0.92	0.75	0.56	1.00	0.95	0.77	0.58	1.00	1.00	0.80	0.60	1.00	1.00	0.81	0.60	ΔT	21	20	17	14	21	20	18	14	21	20	18	14	20	20	17	14	18	19	16	13
	kW	2.52	2.57	2.65	2.74	2.71	2.77	2.86	2.95	2.88	2.94	3.04	3.14	3.03	3.10	3.20	3.31	3.16	3.23	3.33	3.45	3.27	3.34	3.45	3.57	Amps	9.3	9.5	9.8	10.2	10.0	10.3	10.6	11.0	10.9	11.2	11.6	12.0	11.7	12.0	12.4	12.8	12.4	12.7	13.2	13.7	13.2	13.5	14.0	14.5																						
	Hi PR	236	254	268	280	265	285	301	314	301	324	342	357	343	369	390	406	386	415	438	457	426	459	484	505	Lo PR	107	114	125	133	114	121	132	140	118	126	137	146	124	132	144	153	130	138	151	161	134	143	156	166																						
	MBh	34.5	35.2	37.6	40.2	33.7	34.4	36.8	39.3	32.9	33.6	35.9	38.4	32.1	32.8	35.0	37.4	30.5	31.1	33.3	35.5	28.2	28.8	30.8	32.9	S/T	0.88	0.83	0.67	0.50	0.92	0.86	0.70	0.52	0.94	0.88	0.72	0.54	0.97	0.91	0.74	0.55	1.00	0.94	0.77	0.57	1.00	0.95	0.77	0.58																						
	ΔT	22	21	18	15	22	21	19	15	22	21	19	15	22	21	19	15	22	21	18	15	22	21	18	15	20	20	17	14	20	20	17	14	20	20	17	14	20	20	17	14																															
	kW	2.50	2.56	2.64	2.72	2.70	2.75	2.84	2.93	2.86	2.93	3.02	3.12	3.01	3.08	3.18	3.29	3.14	3.21	3.32	3.43	3.25	3.32	3.43	3.55	Amps	9.2	9.5	9.8	10.1	10.0	10.2	10.6	11.0	10.9	11.1	11.5	11.9	11.6	11.9	12.3	12.8	12.4	12.7	13.1	13.6	13.1	13.4	13.9	14.4																						
	Hi PR	234	252	266	278	263	283	299	312	299	322	340	354	341	366	387	404	383	412	435	454	423	456	481	502	Lo PR	107	114	124	132	113	120	131	140	117	125	136	145	123	131	143	152	129	137	150	160	133	142	155	165																						
	MBh	32.7	33.5	35.7	38.2	32.0	32.7	34.9	37.3	31.2	31.9	34.1	36.4	30.5	31.1	33.3	35.5	28.9	29.6	31.6	33.8	26.8	27.4	29.3	31.3	S/T	0.85	0.79	0.65	0.48	0.88	0.82	0.67	0.50	0.90	0.84	0.69	0.51	0.93	0.87	0.71	0.53	0.96	0.90	0.74	0.55	0.97	0.91	0.74	0.55																						
	ΔT	23	22	19	15	23	22	19	15	23	22	19	15	23	22	19	15	23	22	19	15	23	22	19	15	21	21	18	14	21	21	18	14	21	21	18	14	21	21	18	14																															
	kW	2.46	2.52	2.59	2.68	2.65	2.71	2.79	2.89	2.82	2.88	2.97	3.07	2.96	3.03	3.13	3.23	3.09	3.16	3.26	3.37	3.19	3.27	3.37	3.49	Amps	9.1	9.3	9.6	9.9	9.8	10.0	10.4	10.8	10.7	10.9	11.3	11.7	11.4	11.7	12.1	12.5	12.1	12.4	12.8	13.3	12.9	13.2	13.6	14.1																						
Hi PR	230	247	261	272	258	277	293	305	293	315	333	347	334	359	379	396	375	404	427	445	415	446	471	492	Lo PR	105	111	122	129	111	118	128	137	115	122	133	142	121	128	140	149	126	135	147	156	131	139	152	162																							

85	1425	MBh	35.59	36.28	38.00	40.54	34.76	35.44	37.11	39.60	33.94	34.59	36.23	38.65	33.11	33.75	35.35	37.71	31.45	32.06	33.58	35.82	29.14	29.70	31.11	33.19	S/T	0.97	0.93	0.84	0.68	1.00	0.97	0.87	0.71	1.00	0.99	0.90	0.73	1.00	1.00	0.92	0.75	1.00	1.00	0.96	0.78			
	ΔT	22	22	18	15	22	22	18	15	22	22	18	15	21	22	18	15	21	22	18	15	20	21	18	15	19	19	15	17	20	21	18	15	20	21	18	15	19	19	15	17									
	kW	2.54	2.59	2.67	2.76	2.73	2.79	2.88	2.97	2.90	2.97	3.06	3.16	3.06	3.12	3.23	3.33	3.18	3.26	3.36	3.48	3.30	3.37	3.48	3.60	Amps	9.4	9.6	9.9	10.3	10.1	10.4	10.7	11.1	11.0	11.3	11.7	12.1	11.8	12.1	12.5	13.0	12.6	12.9	13.3	13.8	13.3	13.6	14.1	14.6
	Hi PR	238	256	271	282	267	288	304	317	304	327	346	360	346	373	394	411	390	419	443	462	431	463	489	510	Lo PR	109	116	126	134	115	122	133	142	119	127	138	147	125	133	145	155	131	140	152	162	136	144	158	168
	MBh	35.1	35.7	37.4	39.9	34.3	34.9	36.6	39.0	33.4	34.1	35.7	38.1	32.6	33.3	34.8	37.2	31.0	31.6	33.1	35.3	28.7	29.3	30.6	32.7	S/T	0.93	0.89	0.81	0.65	0.96	0.93	0.84	0.68	0.98	0.95	0.86	0.70	1.00	0.98	0.89	0.72	1.00	1.00	0.92	0.75	1.00	1.00	0.93	0.75
	ΔT	23	23	22	19	24	23	22	19	24	23	22	19	24	24	22	19	24	24	22	19	22	23	22	19	21	21	18	15	22	23	22	19	21	21	18	15	21	21	18	15									
	kW	2.52	2.58	2.66	2.74	2.72	2.78	2.86	2.96	2.89	2.95	3.05	3.15	3.04	3.10	3.21	3.31	3.17	3.24	3.34	3.46	3.28	3.35	3.46	3.58	Amps	9.3	9.5	9.9	10.2	10.1	10.3	10.7	11.1	11.0	11.2	11.6	12.0	11.7	12.0	12.4	12.9	12.5	12.8	13.2	13.7	13.2	13.5	14.0	14.5
	Hi PR	237	255	269	280	266	286	302	315	302	325	343	358	344	370	391	408	387	416	440	459	428	460	486	507	Lo PR	108	115	125	133	114	121	132	141	118	126	137	146	124	132	144	154	130	139	151	161	135	143	157	167
	MBh	33.3	34.0	35.6	37.9	32.5	33.2	34.7	37.1	31.8	32.4	33.9	36.2	31.0	31.6	33.1	35.3	29.4	30.0	31.4	33.5	27.3	27.8	29.1	31.1	S/T	0.89	0.86	0.77	0.63	0.92	0.89	0.80	0.65	0.94	0.91	0.82	0.67	0.97	0.94	0.85	0.69	1.00	0.97	0.88	0.71	1.00	0.98	0.89	0.72
	ΔT	24	24	22	19	24	24	23	20	24	24	23	20	25	24	23	20	25	24	23	20	24	24	23	20	22	22	21	18	24	24	23	20	22	22	21	18	22	22	21	18									
kW	2.48	2.54	2.62	2.70	2.67	2.73	2.82	2.91	2.84	2.90	3.00	3.09	2.99	3.05	3.15	3.26	3.11	3.18	3.29	3.40	3.22	3.29	3.40	3.52	Amps	9.1	9.4	9.7	10.0	9.9	10.1	10.5	10.9	10.7	11.0	11.4	11.8	11.5	11.8	12.2	12.6	12.2	12.5	13.0	13.5	13.0	13.3	13.7	14.3	
Hi PR	232	250	264	275	260	280	296	308	296	318	336	351	337	363	383	400	379	408	431	449	419	451	476	497	Lo PR	106	112	123	131	112	119	130	138	116	123	135	144	122	130	142	151	128	136	148	158	132	141	153	163	

IDB: Entering Indoor Dry Bulb Temperature
 High and low pressures are measured at the liquid and suction service valves.
 Shaded area reflects AHR1 (TVVA) conditions
 kW=Total system power
 Amps = outdoor unit amps (compressor + fan)

EXPANDED COOLING DATA — ASZ130421A* / AR*F364216**

IDB	OUTDOOR AMBIENT TEMPERATURE												ENTERING INDOOR WET BULB TEMPERATURE											
	65°F				75°F				85°F				95°F				105°F				115°F			
	59	63	67	71	59	63	67	71	59	63	67	71	59	63	67	71	59	63	67	71	59	63	67	71
70	AIRFLOW																							
	1575																							
	1400																							
	1225																							
	MBh																							
	S/T																							
	ΔT																							
	kW																							
	Amps																							
	Hi PR																							
Lo PR																								
MBh																								
S/T																								
ΔT																								
kW																								
Amps																								
Hi PR																								
Lo PR																								

75	1575																							
	1400																							
	1225																							
	MBh																							
	S/T																							
	ΔT																							
	kW																							
	Amps																							
	Hi PR																							
	Lo PR																							
MBh																								
S/T																								
ΔT																								
kW																								
Amps																								
Hi PR																								
Lo PR																								

IDB: Entering Indoor Dry Bulb Temperature
 High and low pressures are measured at the liquid and suction service valves.
 Shaded area reflects ACCA (TVA) conditions
 kW=Total system power
 Amps = outdoor unit amps (compressor + fan)

EXPANDED COOLING DATA — ASZ130421A* / AR*F364216** (CONT.)

IDB	AIRFLOW	OUTDOOR AMBIENT TEMPERATURE																							
		65°F				75°F				85°F				95°F				105°F				115°F			
		59	63	67	71	59	63	67	71	59	63	67	71	59	63	67	71	59	63	67	71	59	63	67	71
80	MBh	41.08	41.97	44.84	47.94	40.12	41.00	43.80	46.82	39.17	40.02	42.76	45.71	38.21	39.05	41.72	44.59	36.30	37.09	39.63	42.36	33.63	34.36	36.71	39.24
	S/T	0.93	0.87	0.71	0.53	0.96	0.90	0.73	0.55	1.00	0.92	0.75	0.56	1.00	0.95	0.78	0.58	1.00	1.00	0.81	0.60	1.00	1.00	0.81	0.61
	ΔT	22	21	19	15	22	22	19	15	22	22	19	15	22	22	19	15	22	22	19	15	20	20	17	14
	kW	2.93	3.00	3.09	3.18	3.15	3.22	3.32	3.43	3.35	3.42	3.53	3.64	3.52	3.59	3.71	3.83	3.66	3.74	3.87	3.99	3.79	3.87	4.00	4.13
	Amps	11.2	11.5	11.9	12.4	12.2	12.5	12.9	13.4	13.3	13.6	14.1	14.6	14.2	14.6	15.1	15.7	15.2	15.5	16.1	16.7	16.1	16.5	17.1	17.7
	HI PR	246	265	280	292	277	298	314	328	314	338	357	373	358	385	407	425	403	434	458	478	445	479	506	528
	Lo PR	109	116	126	134	115	122	133	142	119	127	138	147	125	133	145	155	131	140	152	162	136	144	158	168
	MBh	39.9	40.8	43.5	46.5	39.0	39.8	42.5	45.5	38.0	38.9	41.5	44.4	37.1	37.9	40.5	43.3	35.2	36.0	38.5	41.1	32.6	33.4	35.6	38.1
	S/T	0.88	0.83	0.67	0.50	0.92	0.86	0.70	0.52	0.94	0.88	0.72	0.54	0.97	0.91	0.74	0.55	1.00	0.94	0.77	0.57	1.00	0.95	0.77	0.58
	ΔT	23	22	19	15	23	22	20	16	23	22	20	16	24	23	20	16	24	23	22	19	21	21	18	14
	kW	2.91	2.97	3.06	3.16	3.13	3.19	3.29	3.40	3.32	3.39	3.50	3.61	3.49	3.57	3.68	3.80	3.63	3.71	3.83	3.96	3.76	3.84	3.97	4.10
	Amps	11.1	11.4	11.8	12.2	12.1	12.4	12.8	13.3	13.1	13.5	13.9	14.5	14.1	14.4	14.9	15.5	15.0	15.4	15.9	16.5	15.9	16.3	16.9	17.6
HI PR	244	263	277	289	274	295	311	324	311	335	354	369	355	382	403	420	399	429	453	473	441	474	501	522	
Lo PR	107	114	125	133	114	121	132	140	118	126	137	146	124	132	144	153	130	138	151	161	134	143	156	166	
MBh	36.8	37.6	40.2	43.0	36.0	36.7	39.3	42.0	35.1	35.9	38.3	41.0	34.2	35.0	37.4	40.0	32.5	33.2	35.5	38.0	30.1	30.8	32.9	35.2	
S/T	0.85	0.80	0.65	0.49	0.88	0.83	0.67	0.50	0.91	0.85	0.69	0.52	0.93	0.88	0.71	0.53	0.97	0.91	0.74	0.55	0.98	0.92	0.75	0.56	
ΔT	24	23	20	16	24	23	20	16	24	23	20	16	24	23	20	16	24	23	22	19	22	21	18	15	
kW	2.84	2.90	2.99	3.08	3.06	3.12	3.22	3.32	3.24	3.31	3.41	3.52	3.41	3.48	3.59	3.71	3.55	3.62	3.74	3.86	3.67	3.75	3.87	3.99	
Amps	10.8	11.1	11.5	11.9	11.7	12.0	12.4	12.9	12.8	13.1	13.5	14.1	13.7	14.0	14.5	15.1	14.6	15.0	15.5	16.1	15.5	15.9	16.4	17.1	
HI PR	237	255	269	281	266	286	302	315	302	325	343	358	344	370	391	408	387	416	440	459	428	460	486	507	
Lo PR	104	111	121	129	110	117	128	136	114	122	133	142	120	128	140	149	126	134	146	156	130	139	151	161	

1575	MBh	41.79	42.60	44.62	47.60	40.82	41.61	43.58	46.50	39.85	40.62	42.54	45.39	38.88	39.63	41.51	44.28	36.93	37.65	39.43	42.07	34.21	34.88	36.53	38.97
	S/T	0.97	0.94	0.85	0.69	1.00	0.97	0.88	0.71	1.00	1.00	0.90	0.73	1.00	1.00	0.93	0.75	1.00	1.00	0.96	0.78	1.00	1.00	0.97	0.79
	ΔT	24	23	22	19	24	24	22	19	23	24	22	19	23	23	22	19	22	22	22	19	20	20	21	18
	kW	2.96	3.02	3.11	3.21	3.18	3.25	3.35	3.45	3.37	3.45	3.56	3.67	3.55	3.62	3.74	3.86	3.69	3.77	3.90	4.03	3.82	3.90	4.03	4.17
	Amps	11.3	11.6	12.0	12.5	12.3	12.6	13.0	13.5	13.4	13.7	14.2	14.8	14.3	14.7	15.2	15.8	15.3	15.7	16.2	16.9	16.2	16.7	17.2	17.9
	HI PR	249	268	283	295	279	301	317	331	318	342	361	376	362	389	411	429	407	438	462	482	450	484	511	533
	Lo PR	110	117	127	136	116	123	135	143	120	128	140	149	126	135	147	156	133	141	154	164	137	146	159	170
	MBh	40.6	41.4	43.3	46.2	39.6	40.4	42.3	45.1	38.7	39.4	41.3	44.1	37.7	38.5	40.3	43.0	35.9	36.6	38.3	40.8	33.2	33.9	35.5	37.8
	S/T	0.93	0.89	0.81	0.65	0.96	0.93	0.84	0.68	0.98	0.95	0.86	0.70	1.00	0.98	0.89	0.72	1.00	1.00	0.92	0.75	1.00	1.00	0.93	0.75
	ΔT	25	24	23	20	25	25	23	20	25	25	23	20	25	25	23	20	24	24	23	20	22	22	22	19
	kW	2.93	3.00	3.09	3.18	3.15	3.22	3.32	3.43	3.35	3.42	3.53	3.64	3.52	3.59	3.71	3.83	3.66	3.74	3.87	3.99	3.79	3.87	4.00	4.13
	Amps	11.2	11.5	11.9	12.4	12.2	12.5	12.9	13.4	13.3	13.6	14.1	14.6	14.2	14.6	15.1	15.7	15.2	15.5	16.1	16.7	16.1	16.5	17.1	17.7
HI PR	246	265	280	292	277	298	314	328	314	338	357	373	358	385	407	425	403	434	458	478	445	479	506	528	
Lo PR	109	116	126	134	115	122	133	142	119	127	138	147	125	133	145	155	131	140	152	162	136	144	158	168	
MBh	37.5	38.2	40.0	42.7	36.6	37.3	39.1	41.7	35.7	36.4	38.1	40.7	34.8	35.5	37.2	39.7	33.1	33.7	35.3	37.7	30.7	31.3	32.7	34.9	
S/T	0.89	0.86	0.78	0.63	0.93	0.89	0.81	0.65	0.95	0.92	0.83	0.67	0.98	0.95	0.85	0.69	1.00	0.98	0.89	0.72	1.00	0.99	0.89	0.72	
ΔT	25	25	23	20	25	25	24	20	25	25	24	20	26	25	24	21	25	25	23	20	23	23	22	19	
kW	2.87	2.93	3.01	3.11	3.08	3.14	3.24	3.34	3.27	3.34	3.44	3.55	3.43	3.51	3.62	3.74	3.57	3.65	3.77	3.89	3.70	3.78	3.90	4.03	
Amps	10.9	11.2	11.6	12.0	11.8	12.1	12.5	13.0	12.9	13.2	13.7	14.2	13.8	14.2	14.6	15.2	14.7	15.1	15.6	16.2	15.6	16.0	16.6	17.2	
HI PR	239	257	272	283	268	289	305	318	305	328	347	362	347	374	395	412	391	421	444	463	432	465	491	512	
Lo PR	105	112	122	130	111	118	129	138	116	123	134	143	121	129	141	150	127	135	148	157	132	140	153	163	

IDB: Entering Indoor Dry Bulb Temperature
 High and low pressures are measured at the liquid and suction service valves.
 Shaded area reflects AHR1 (TVVA) conditions
 kW=Total system power
 Amps = outdoor unit amps (compressor + fan)

EXPANDED COOLING DATA — ASZ130481A* / AR*F486016**

IDB	AIRFLOW	OUTDOOR AMBIENT TEMPERATURE												ENTERING INDOOR WET BULB TEMPERATURE											
		65°F				75°F				85°F				95°F				105°F				115°F			
		59	63	67	71	59	63	67	71	59	63	67	71	59	63	67	71	59	63	67	71	59	63	67	71
1688	MBh	45.1	46.7	51.2	-	44.0	45.6	50.0	-	43.0	44.5	48.8	-	41.9	43.5	47.6	-	39.8	41.3	45.2	-	36.9	38.2	41.9	-
	S/T	0.75	0.63	0.44	-	0.78	0.65	0.45	-	0.80	0.67	0.46	-	0.83	0.69	0.48	-	0.86	0.72	0.50	-	0.86	0.72	0.50	-
	ΔT	19	16	12	-	19	16	12	-	19	16	12	-	19	16	12	-	19	16	12	-	17	15	11	-
	kW	3.29	3.35	3.46	-	3.53	3.60	3.71	-	3.74	3.82	3.94	-	3.93	4.02	4.15	-	4.09	4.18	4.32	-	4.23	4.32	4.47	-
	Amps	11.9	12.1	12.6	-	12.8	13.2	13.6	-	14.0	14.3	14.8	-	15.0	15.4	15.9	-	16.0	16.4	16.9	-	16.9	17.4	18.0	-
	Hi PR	235	253	267	-	264	284	300	-	300	323	341	-	341	367	388	-	384	413	437	-	424	457	482	-
	Lo PR	109	116	127	-	116	123	134	-	120	128	139	-	126	134	146	-	132	141	154	-	137	145	159	-
	MBh	43.8	45.4	49.7	-	42.7	44.3	48.5	-	41.7	43.2	47.4	-	40.7	42.2	46.2	-	38.7	40.1	43.9	-	35.8	37.1	40.7	-
	S/T	0.72	0.60	0.42	-	0.74	0.62	0.43	-	0.76	0.64	0.44	-	0.79	0.66	0.46	-	0.82	0.68	0.47	-	0.82	0.69	0.48	-
	ΔT	19	17	13	-	20	17	13	-	20	17	13	-	20	17	13	-	19	17	13	-	18	16	12	-
	kW	3.26	3.33	3.43	-	3.50	3.58	3.69	-	3.71	3.79	3.91	-	3.90	3.99	4.11	-	4.06	4.15	4.28	-	4.20	4.29	4.43	-
	Amps	11.7	12.0	12.4	-	12.7	13.0	13.5	-	13.9	14.2	14.7	-	14.8	15.2	15.7	-	15.8	16.2	16.8	-	16.8	17.2	17.8	-
Hi PR	233	250	264	-	261	281	297	-	297	319	337	-	338	364	384	-	380	409	432	-	420	452	478	-	
Lo PR	108	115	126	-	114	122	133	-	119	126	138	-	125	133	145	-	131	139	152	-	135	144	157	-	
MBh	40.4	41.9	45.9	-	39.5	40.9	44.8	-	38.5	39.9	43.7	-	37.6	38.9	42.7	-	35.7	37.0	40.5	-	33.1	34.3	37.5	-	
S/T	0.69	0.58	0.40	-	0.72	0.60	0.42	-	0.74	0.61	0.43	-	0.76	0.63	0.44	-	0.79	0.66	0.46	-	0.80	0.66	0.46	-	
ΔT	20	17	13	-	20	17	13	-	20	17	13	-	20	17	13	-	20	17	13	-	18	16	12	-	
kW	3.19	3.25	3.35	-	3.42	3.49	3.60	-	3.63	3.70	3.82	-	3.81	3.89	4.01	-	3.96	4.05	4.18	-	4.10	4.18	4.32	-	
Amps	11.4	11.7	12.1	-	12.4	12.7	13.1	-	13.5	13.8	14.3	-	14.4	14.8	15.3	-	15.4	15.8	16.3	-	16.3	16.7	17.3	-	
Hi PR	226	243	256	-	253	272	288	-	288	310	327	-	328	353	373	-	369	397	419	-	408	439	463	-	
Lo PR	105	112	122	-	111	118	129	-	115	123	134	-	121	129	141	-	127	135	147	-	131	140	153	-	
1500	MBh	45.84	47.20	51.09	54.83	44.77	46.10	49.90	53.55	43.71	45.00	48.71	52.28	42.64	43.90	47.52	51.00	40.51	41.71	45.15	48.45	37.52	38.64	41.82	44.88
	S/T	0.86	0.77	0.58	0.37	0.89	0.79	0.60	0.39	0.91	0.81	0.62	0.40	0.94	0.84	0.64	0.41	0.97	0.87	0.66	0.42	0.98	0.88	0.67	0.43
	ΔT	21	20	16	11	22	20	16	11	22	20	16	11	22	20	16	11	22	20	16	11	20	19	15	10
	kW	3.31	3.38	3.48	3.59	3.56	3.63	3.74	3.86	3.77	3.85	3.98	4.10	3.97	4.05	4.18	4.32	4.13	4.22	4.35	4.50	4.27	4.36	4.50	4.65
	Amps	12.0	12.3	12.7	13.2	13.0	13.3	13.7	14.3	14.1	14.5	15.0	15.6	15.1	15.5	16.0	16.7	16.1	16.5	17.1	17.8	17.1	17.5	18.2	18.9
	Hi PR	237	255	270	281	266	287	303	316	303	326	344	359	345	371	392	409	388	418	441	460	429	461	487	508
	Lo PR	110	118	128	137	117	124	136	144	121	129	141	150	127	136	148	158	134	142	155	165	138	147	160	171
	MBh	44.5	45.8	49.6	53.2	43.5	44.8	48.4	52.0	42.4	43.7	47.3	50.8	41.4	42.6	46.1	49.5	39.3	40.5	43.8	47.0	36.4	37.5	40.6	43.6
	S/T	0.82	0.73	0.55	0.36	0.85	0.76	0.57	0.37	0.87	0.78	0.59	0.38	0.90	0.80	0.61	0.39	0.93	0.83	0.63	0.40	0.94	0.84	0.63	0.41
	ΔT	22	21	17	12	23	21	17	12	23	21	17	12	23	21	17	12	22	21	17	12	21	19	16	11
	kW	3.29	3.35	3.46	3.56	3.53	3.60	3.72	3.83	3.74	3.82	3.94	4.07	3.93	4.02	4.15	4.28	4.09	4.18	4.32	4.46	4.23	4.33	4.47	4.61
	Amps	11.9	12.1	12.6	13.0	12.8	13.2	13.6	14.1	14.0	14.3	14.8	15.4	15.0	15.4	15.9	16.5	16.0	16.4	16.9	17.6	17.0	17.4	18.0	18.7
Hi PR	235	253	267	278	264	284	300	312	300	323	341	355	342	368	388	405	384	413	437	455	424	457	482	503	
Lo PR	109	116	127	135	116	123	134	143	120	128	139	149	126	134	147	156	132	141	154	164	137	145	159	169	
MBh	41.1	42.3	45.8	49.1	40.1	41.3	44.7	48.0	39.2	40.3	43.7	46.8	38.2	39.34	42.6	45.7	36.3	37.4	40.5	43.4	33.6	34.6	37.5	40.2	
S/T	0.79	0.70	0.53	0.34	0.82	0.73	0.55	0.36	0.84	0.75	0.57	0.36	0.86	0.77	0.58	0.38	0.90	0.80	0.61	0.39	0.90	0.81	0.61	0.39	
ΔT	23	21	17	12	23	21	17	12	23	21	17	12	23	21	17	12	23	21	17	12	21	20	16	11	
kW	3.21	3.28	3.38	3.48	3.45	3.52	3.63	3.74	3.66	3.73	3.85	3.97	3.84	3.92	4.05	4.18	4.00	4.08	4.21	4.35	4.13	4.22	4.36	4.50	
Amps	11.5	11.8	12.2	12.7	12.5	12.8	13.2	13.7	13.6	13.9	14.4	15.0	14.6	14.9	15.4	16.0	15.5	15.9	16.5	17.1	16.5	16.9	17.5	18.1	
Hi PR	228	245	259	270	256	275	291	303	291	313	331	345	331	356	376	393	373	401	423	442	412	443	468	488	
Lo PR	106	113	123	131	112	119	130	139	116	124	135	144	122	130	142	151	128	136	149	159	133	141	154	164	

IDB: Entering Indoor Dry Bulb Temperature
 High and low pressures are measured at the liquid and suction service valves.
 Shaded area reflects ACCA (TVA) conditions
 kW=Total system power
 Amps = outdoor unit amps (compressor + fan)

EXPANDED COOLING DATA — ASZ130481A* / AR*F486016** (CONT.)

IDB	AIRFLOW	OUTDOOR AMBIENT TEMPERATURE																							
		65°F				75°F				85°F				95°F				105°F				115°F			
		59	63	67	71	59	63	67	71	59	63	67	71	59	63	67	71	59	63	67	71	59	63	67	71
80	MBh	46.66	47.67	50.93	54.45	45.57	46.57	49.75	53.18	44.49	45.46	48.56	51.92	43.40	44.35	47.38	50.65	41.23	42.13	45.01	48.12	38.19	39.03	41.69	44.57
	S/T	0.94	0.88	0.72	0.54	1.00	0.91	0.74	0.56	1.00	0.94	0.76	0.57	1.00	0.97	0.79	0.59	1.00	1.00	0.82	0.61	1.00	1.00	0.82	0.62
	ΔT	24	23	20	16	25	23	20	16	24	23	20	16	24	23	20	16	22	21	20	16	21	21	19	15
	kW	3.34	3.41	3.51	3.62	3.59	3.66	3.77	3.89	3.80	3.89	4.01	4.14	4.00	4.08	4.21	4.35	4.16	4.25	4.39	4.53	4.30	4.40	4.54	4.69
	Amps	12.1	12.4	12.8	13.3	13.1	13.4	13.9	14.4	14.3	14.6	15.1	15.7	15.3	15.7	16.2	16.8	16.3	16.7	17.3	17.9	17.3	17.7	18.3	19.0
	HI PR	240	258	272	284	269	289	306	319	306	329	348	363	348	375	396	413	392	422	445	465	433	466	492	513
	Lo PR	112	119	130	138	118	125	137	146	123	130	142	152	129	137	149	159	135	143	157	167	140	148	162	173
	MBh	45.3	46.3	49.5	52.9	44.2	45.2	48.3	51.6	43.2	44.1	47.2	50.4	42.1	43.1	46.0	49.2	40.0	40.9	43.7	46.7	37.1	37.9	40.5	43.3
	S/T	0.90	0.84	0.68	0.51	0.93	0.87	0.71	0.53	0.95	0.89	0.73	0.54	0.98	0.92	0.75	0.56	1.00	0.96	0.78	0.58	1.00	0.96	0.78	0.59
	ΔT	25	24	21	17	25	24	21	17	25	24	21	17	25	24	21	17	25	24	21	17	23	22	19	16
kW	3.31	3.38	3.48	3.59	3.56	3.63	3.74	3.86	3.77	3.85	3.98	4.10	3.97	4.05	4.18	4.32	4.13	4.22	4.35	4.50	4.27	4.36	4.50	4.65	
Amps	12.0	12.3	12.7	13.2	13.0	13.3	13.7	14.3	14.1	14.5	15.0	15.6	15.1	15.5	16.0	16.7	16.1	16.5	17.1	17.8	17.1	17.5	18.2	18.9	
HI PR	237	255	270	281	266	287	303	316	303	326	344	359	345	371	392	409	388	418	441	460	429	461	487	508	
Lo PR	110	118	128	137	117	124	136	144	121	129	141	150	127	136	148	158	134	142	155	165	138	147	160	171	
MBh	41.8	42.7	45.6	48.8	40.8	41.7	44.6	47.7	39.9	40.7	43.5	46.5	38.9	39.7	42.5	45.4	36.9	37.8	40.3	43.1	34.2	35.0	37.4	39.9	
S/T	0.86	0.81	0.66	0.49	0.90	0.84	0.68	0.51	0.92	0.86	0.70	0.52	0.95	0.89	0.72	0.54	0.98	0.92	0.75	0.56	0.99	0.93	0.76	0.57	
ΔT	25	24	21	17	26	25	21	17	26	25	21	17	26	25	21	17	26	25	21	17	24	23	20	16	
kW	3.24	3.30	3.40	3.51	3.47	3.55	3.66	3.77	3.68	3.76	3.88	4.00	3.87	3.95	4.08	4.21	4.03	4.11	4.25	4.38	4.16	4.25	4.39	4.54	
Amps	11.6	11.9	12.3	12.8	12.6	12.9	13.4	13.9	13.7	14.1	14.6	15.1	14.7	15.1	15.6	16.2	15.7	16.1	16.6	17.3	16.6	17.0	17.6	18.3	
HI PR	230	248	262	273	258	278	294	306	294	316	334	348	335	360	380	397	376	405	428	446	416	448	473	493	
Lo PR	107	114	124	133	113	120	132	140	118	125	137	146	124	132	144	153	130	138	150	160	134	143	156	166	

1688	MBh	47.47	48.39	50.68	54.07	46.37	47.26	49.50	52.81	45.26	46.14	48.32	51.55	44.16	45.01	47.14	50.29	41.95	42.76	44.79	47.78	38.86	39.61	41.49	44.26
	S/T	0.98	0.95	0.86	0.70	1.00	0.98	0.89	0.72	1.00	1.00	0.91	0.74	1.00	1.00	0.94	0.76	1.00	1.00	0.98	0.79	1.00	1.00	0.98	0.80
	ΔT	25	25	24	20	25	25	24	21	25	25	24	21	24	25	24	21	24	23	24	21	21	21	22	19
	kW	3.36	3.43	3.54	3.65	3.61	3.69	3.80	3.93	3.83	3.92	4.04	4.17	4.03	4.12	4.25	4.39	4.20	4.29	4.43	4.57	4.34	4.43	4.58	4.73
	Amps	12.2	12.5	12.9	13.4	13.2	13.5	14.0	14.5	14.4	14.8	15.3	15.9	15.4	15.8	16.3	17.0	16.4	16.9	17.4	18.1	17.4	17.9	18.5	19.2
	HI PR	242	261	275	287	272	292	309	322	309	332	351	366	352	379	400	417	396	426	450	469	437	471	497	518
	Lo PR	113	120	131	139	119	127	138	147	124	132	144	153	130	138	151	161	136	145	158	169	141	150	164	174
	MBh	46.1	47.0	49.2	52.5	45.0	45.9	48.1	51.3	43.9	44.8	46.9	50.1	42.9	43.7	45.8	48.8	40.7	41.5	43.5	46.4	37.7	38.5	40.3	43.0
	S/T	0.94	0.91	0.82	0.66	0.97	0.94	0.85	0.69	1.00	0.96	0.87	0.71	1.00	0.99	0.90	0.73	1.00	1.00	0.93	0.76	1.00	1.00	0.94	0.76
	ΔT	27	26	25	21	27	26	25	22	27	26	25	22	26	27	25	22	25	25	25	21	23	24	23	20
kW	3.34	3.41	3.51	3.62	3.59	3.66	3.77	3.89	3.80	3.89	4.01	4.14	4.00	4.08	4.21	4.35	4.16	4.25	4.39	4.53	4.30	4.40	4.54	4.69	
Amps	12.1	12.4	12.8	13.3	13.1	13.4	13.9	14.4	14.3	14.6	15.1	15.7	15.3	15.7	16.2	16.8	16.3	16.7	17.3	17.9	17.3	17.7	18.3	19.0	
HI PR	240	258	272	284	269	289	306	319	306	329	348	363	348	375	396	413	392	422	445	465	433	466	492	513	
Lo PR	112	119	130	138	118	125	137	146	123	130	142	152	129	137	149	159	135	143	157	167	140	148	162	173	
MBh	42.5	43.4	45.4	48.5	41.5	42.4	44.4	47.3	40.6	41.3	43.3	46.2	39.6	40.3	42.2	45.1	37.6	38.3	40.1	42.8	34.8	35.5	37.2	39.7	
S/T	0.91	0.87	0.79	0.64	0.94	0.91	0.82	0.66	0.96	0.93	0.84	0.68	0.99	0.96	0.86	0.70	1.00	0.99	0.90	0.73	1.00	1.00	0.91	0.73	
ΔT	27	27	25	22	27	27	25	22	27	27	25	22	28	27	26	22	26	27	25	22	24	25	24	20	
kW	3.26	3.33	3.43	3.53	3.50	3.57	3.68	3.80	3.71	3.79	3.91	4.04	3.90	3.98	4.11	4.24	4.06	4.15	4.28	4.42	4.20	4.29	4.43	4.57	
Amps	11.7	12.0	12.4	12.9	12.7	13.0	13.5	14.0	13.9	14.2	14.7	15.3	14.8	15.2	15.7	16.3	15.8	16.2	16.8	17.4	16.8	17.2	17.8	18.5	
HI PR	233	250	264	276	261	281	296	309	297	319	337	352	338	364	384	401	380	409	432	451	420	452	477	498	
Lo PR	108	115	126	134	114	122	133	141	119	126	138	147	125	133	145	154	131	139	152	162	135	144	157	167	

IDB: Entering Indoor Dry Bulb Temperature
 High and low pressures are measured at the liquid and suction service valves.
 Shaded area reflects AHR1 (TVFA) conditions
 kW=Total system power
 Amps = outdoor unit amps (compressor + fan)

EXPANDED COOLING DATA — ASZ130601A* / AR*F486016**

IDB	AIRFLOW	OUTDOOR AMBIENT TEMPERATURE																							
		65°F				75°F				85°F				95°F				105°F				115°F			
		59	63	67	71	59	63	67	71	59	63	67	71	59	63	67	71	59	63	67	71	59	63	67	71
70	MBh	55.9	57.9	63.4	-	54.6	56.5	62.0	-	53.3	55.2	60.5	-	52.0	53.9	59.0	-	49.4	51.2	56.1	-	45.7	47.4	51.9	-
	S/T	0.73	0.61	0.42	-	0.76	0.63	0.44	-	0.78	0.65	0.45	-	0.80	0.67	0.46	-	0.83	0.70	0.48	-	0.84	0.70	0.49	-
	ΔT	19	16	12	-	19	16	12	-	19	16	12	-	19	16	12	-	19	16	12	-	17	15	11	-
	kW	4.06	4.14	4.26	-	4.35	4.44	4.58	-	4.61	4.71	4.85	-	4.84	4.94	5.10	-	5.04	5.14	5.31	-	5.20	5.32	5.48	-
	Amps	15.3	15.7	16.2	-	16.6	17.0	17.6	-	18.1	18.5	19.2	-	19.4	19.9	20.6	-	20.7	21.2	21.9	-	22.0	22.5	23.3	-
	HI PR	228	245	259	-	256	275	290	-	291	313	330	-	331	356	376	-	372	401	423	-	411	443	468	-
	Lo PR	104	111	121	-	110	117	128	-	114	122	133	-	120	128	140	-	126	134	146	-	130	139	151	-
	MBh	54.2	56.2	61.6	-	53.0	54.9	60.1	-	51.7	53.6	58.7	-	50.4	52.3	57.3	-	47.9	49.7	54.4	-	44.4	46.0	50.4	-
	S/T	0.70	0.58	0.40	-	0.72	0.60	0.42	-	0.74	0.62	0.43	-	0.77	0.64	0.44	-	0.79	0.66	0.46	-	0.80	0.67	0.46	-
	ΔT	19	17	13	-	20	17	13	-	20	17	13	-	20	17	13	-	19	17	13	-	18	16	12	-
	kW	4.03	4.11	4.23	-	4.32	4.41	4.54	-	4.58	4.67	4.82	-	4.80	4.90	5.06	-	5.00	5.10	5.26	-	5.16	5.27	5.44	-
	Amps	15.2	15.5	16.1	-	16.4	16.8	17.4	-	17.9	18.4	19.0	-	19.2	19.7	20.4	-	20.5	21.0	21.7	-	21.8	22.3	23.1	-
HI PR	225	243	256	-	253	272	287	-	288	310	327	-	328	353	372	-	369	397	419	-	407	438	463	-	
Lo PR	103	110	120	-	109	116	127	-	113	120	132	-	119	127	138	-	125	133	145	-	129	137	150	-	
MBh	50.1	51.9	56.8	-	48.9	50.7	55.5	-	47.7	49.5	54.2	-	46.6	48.3	52.9	-	44.2	45.8	50.2	-	41.0	42.5	46.5	-	
S/T	0.67	0.56	0.39	-	0.70	0.58	0.40	-	0.71	0.60	0.41	-	0.74	0.62	0.43	-	0.77	0.64	0.44	-	0.77	0.64	0.45	-	
ΔT	20	17	13	-	20	17	13	-	20	17	13	-	20	17	13	-	20	17	13	-	18	16	12	-	
kW	3.94	4.02	4.14	-	4.22	4.31	4.44	-	4.47	4.56	4.70	-	4.69	4.79	4.94	-	4.88	4.98	5.14	-	5.04	5.15	5.31	-	
Amps	14.7	15.1	15.6	-	16.0	16.4	16.9	-	17.4	17.8	18.5	-	18.7	19.1	19.8	-	19.9	20.4	21.1	-	21.1	21.7	22.4	-	
HI PR	219	235	249	-	245	264	279	-	279	300	317	-	318	342	361	-	358	385	406	-	395	425	449	-	
Lo PR	100	106	116	-	106	112	123	-	110	117	128	-	115	123	134	-	121	129	140	-	125	133	145	-	

2025	MBh	56.80	58.48	63.30	67.94	55.48	57.12	61.83	66.36	54.16	55.76	60.36	64.78	52.84	54.40	58.89	63.20	50.20	51.68	55.94	60.04	46.50	47.87	51.82	55.62
	S/T	0.83	0.74	0.56	0.36	0.86	0.77	0.58	0.38	0.88	0.79	0.60	0.38	0.91	0.82	0.62	0.40	0.95	0.85	0.64	0.41	0.95	0.85	0.65	0.42
	ΔT	21	20	16	11	22	20	16	11	22	20	16	11	22	20	17	11	22	20	16	11	20	19	15	10
	kW	4.09	4.17	4.30	4.43	4.39	4.48	4.61	4.76	4.65	4.75	4.89	5.05	4.88	4.98	5.14	5.30	5.08	5.19	5.35	5.52	5.25	5.36	5.53	5.71
	Amps	15.4	15.8	16.4	17.0	16.7	17.2	17.8	18.5	18.3	18.7	19.4	20.1	19.6	20.1	20.8	21.6	20.9	21.4	22.2	23.0	22.2	22.7	23.5	24.5
	HI PR	230	248	261	273	258	278	293	306	294	316	334	348	334	360	380	396	376	405	427	446	416	447	472	493
	Lo PR	105	112	122	130	111	118	129	138	116	123	134	143	121	129	141	150	127	135	148	157	132	140	153	163
	MBh	55.1	56.8	61.5	66.0	53.9	55.5	60.0	64.4	52.6	54.1	58.6	62.9	51.3	52.8	57.2	61.4	48.7	50.2	54.3	58.3	45.1	46.5	50.3	54.0
	S/T	0.79	0.71	0.54	0.35	0.82	0.73	0.56	0.36	0.84	0.75	0.57	0.37	0.87	0.78	0.59	0.38	0.90	0.81	0.61	0.39	0.91	0.81	0.62	0.40
	ΔT	22	21	17	12	23	21	17	12	23	21	17	12	23	21	17	12	22	21	17	12	21	19	16	11
	kW	4.06	4.14	4.26	4.39	4.35	4.44	4.58	4.72	4.61	4.71	4.85	5.01	4.84	4.94	5.10	5.26	5.04	5.14	5.31	5.48	5.20	5.32	5.49	5.66
	Amps	15.3	15.7	16.2	16.8	16.6	17.0	17.6	18.3	18.1	18.6	19.2	19.9	19.4	19.9	20.6	21.4	20.7	21.2	22.0	22.8	22.0	22.5	23.3	24.2
HI PR	228	245	259	270	256	275	290	303	291	313	330	345	331	356	376	392	372	401	423	441	412	443	468	488	
Lo PR	104	111	121	129	110	117	128	136	114	122	133	142	120	128	140	149	126	134	146	156	130	139	151	161	
MBh	50.9	52.4	56.7	60.9	49.7	51.2	55.4	59.5	48.5	50.0	54.1	58.1	47.3	48.75	52.8	56.6	45.0	46.3	50.1	53.8	41.7	42.9	46.4	49.8	
S/T	0.76	0.68	0.52	0.33	0.79	0.71	0.54	0.35	0.81	0.73	0.55	0.35	0.84	0.75	0.57	0.37	0.87	0.78	0.59	0.38	0.88	0.78	0.59	0.38	
ΔT	23	21	17	12	23	21	17	12	23	21	17	12	23	21	17	12	23	21	17	12	21	20	16	11	
kW	3.97	4.05	4.17	4.29	4.25	4.34	4.47	4.61	4.51	4.60	4.74	4.89	4.73	4.83	4.98	5.13	4.92	5.02	5.18	5.34	5.08	5.19	5.35	5.52	
Amps	14.9	15.2	15.8	16.4	16.1	16.5	17.1	17.8	17.6	18.0	18.6	19.4	18.8	19.3	20.0	20.8	20.1	20.6	21.3	22.2	21.3	21.9	22.6	23.5	
HI PR	221	238	251	262	248	267	282	294	282	303	320	334	321	346	365	381	361	389	411	428	399	430	454	473	
Lo PR	101	108	117	125	107	114	124	132	111	118	129	137	117	124	135	144	122	130	142	151	126	134	147	156	

IDB: Entering Indoor Dry Bulb Temperature
 High and low pressures are measured at the liquid and suction service valves.
 Shaded area reflects ACCA (TVA) conditions
 kW=Total system power
 Amps = outdoor unit amps (compressor + fan)

EXPANDED COOLING DATA — ASZ130601A* / AR*F486016** (CONT.)

IDB	AIRFLOW	OUTDOOR AMBIENT TEMPERATURE																							
		65°F				75°F				85°F				95°F				105°F				115°F			
		59	63	67	71	59	63	67	71	59	63	67	71	59	63	67	71	59	63	67	71	59	63	67	71
2025	MBh	57.81	59.07	63.11	67.47	56.47	57.70	61.65	65.90	55.12	56.33	60.18	64.33	53.78	54.95	58.71	62.76	51.09	52.20	55.77	59.62	47.32	48.36	51.66	55.23
	S/T	0.91	0.85	0.70	0.52	0.94	0.89	0.72	0.54	0.97	0.91	0.74	0.55	1.00	0.94	0.76	0.57	1.00	1.00	0.79	0.59	1.00	1.00	0.80	0.60
	ΔT	24	23	20	16	24	23	20	16	24	23	20	16	24	23	20	16	24	23	20	16	21	22	19	15
	kW	4.12	4.20	4.33	4.46	4.42	4.51	4.65	4.79	4.69	4.78	4.93	5.09	4.92	5.02	5.18	5.35	5.12	5.23	5.39	5.57	5.29	5.40	5.58	5.76
	Amps	15.6	16.0	16.5	17.2	16.9	17.3	17.9	18.6	18.4	18.9	19.6	20.3	19.8	20.3	21.0	21.8	21.1	21.6	22.4	23.3	22.4	23.0	23.8	24.7
	Hi PR	232	250	264	275	261	281	296	309	297	319	337	351	338	363	384	400	380	409	432	450	420	452	477	498
	Lo PR	106	113	123	131	112	119	130	139	117	124	136	144	123	130	142	152	129	137	149	159	133	141	154	164
	MBh	56.1	57.4	61.3	65.5	54.8	56.0	59.9	64.0	53.5	54.7	58.4	62.5	52.2	53.4	57.0	60.9	49.6	50.7	54.2	57.9	45.9	46.9	50.2	53.6
	S/T	0.87	0.82	0.66	0.50	0.90	0.85	0.69	0.51	0.92	0.87	0.71	0.53	0.95	0.89	0.73	0.54	0.99	0.93	0.76	0.56	1.00	0.94	0.76	0.57
	ΔT	25	24	21	17	25	24	21	17	25	24	21	17	25	24	21	17	25	24	21	17	23	22	20	16
80	kW	4.09	4.17	4.30	4.43	4.39	4.48	4.61	4.76	4.65	4.75	4.89	5.05	4.88	4.98	5.14	5.30	5.08	5.19	5.35	5.52	5.25	5.36	5.53	5.71
	Amps	15.4	15.8	16.4	17.0	16.8	17.2	17.8	18.5	18.3	18.7	19.4	20.1	19.6	20.1	20.8	21.6	20.9	21.4	22.2	23.0	22.2	22.7	23.5	24.5
	Hi PR	230	248	261	273	258	278	293	306	294	316	334	348	334	360	380	396	376	405	428	446	416	447	472	493
	Lo PR	105	112	122	130	111	118	129	138	116	123	134	143	121	129	141	150	127	135	148	157	132	140	153	163
	MBh	51.8	52.9	56.6	60.5	50.6	51.7	55.2	59.1	49.4	50.5	53.9	57.6	48.2	49.2	52.6	56.2	45.8	46.8	50.0	53.4	42.4	43.3	46.3	49.5
	S/T	0.84	0.79	0.64	0.48	0.87	0.81	0.66	0.50	0.89	0.84	0.68	0.51	0.92	0.86	0.70	0.52	0.95	0.90	0.73	0.54	0.96	0.90	0.73	0.55
	ΔT	25	24	21	17	26	25	21	17	26	25	21	17	26	25	22	17	26	24	21	17	24	23	20	16
	kW	4.00	4.08	4.20	4.33	4.29	4.37	4.51	4.65	4.54	4.64	4.78	4.93	4.77	4.87	5.02	5.18	4.96	5.06	5.22	5.39	5.12	5.23	5.40	5.57
	Amps	15.0	15.4	15.9	16.5	16.3	16.7	17.3	17.9	17.7	18.2	18.8	19.6	19.0	19.5	20.2	21.0	20.3	20.8	21.5	22.4	21.5	22.1	22.9	23.8
	Hi PR	223	240	254	265	250	269	285	297	285	306	324	338	324	349	369	384	365	393	415	433	403	434	458	478
Lo PR	102	109	119	126	108	115	125	133	112	119	130	139	118	125	137	146	123	131	143	153	128	136	148	158	

2025	MBh	58.82	59.96	62.80	67.00	57.45	58.57	61.34	65.44	56.09	57.17	59.88	63.88	54.72	55.78	58.42	62.32	51.98	52.99	55.50	59.21	48.15	49.08	51.41	54.84
	S/T	0.96	0.92	0.83	0.68	0.99	0.96	0.86	0.70	1.00	0.98	0.88	0.72	1.00	1.00	0.91	0.74	1.00	1.00	0.95	0.77	1.00	1.00	0.96	0.78
	ΔT	26	25	24	21	26	25	24	21	25	25	24	21	25	25	24	21	24	24	24	21	22	22	22	19
	kW	4.15	4.24	4.36	4.50	4.46	4.55	4.69	4.83	4.72	4.82	4.97	5.13	4.96	5.06	5.22	5.39	5.16	5.27	5.44	5.61	5.33	5.45	5.62	5.80
	Amps	15.7	16.1	16.7	17.3	17.1	17.5	18.1	18.8	18.6	19.1	19.7	20.5	20.0	20.5	21.2	22.0	21.3	21.8	22.6	23.5	22.6	23.2	24.0	24.9
	Hi PR	235	253	267	278	263	283	299	312	300	322	340	355	341	367	388	404	384	413	436	455	424	456	482	503
	Lo PR	107	114	125	133	113	121	132	140	118	125	137	146	124	132	144	153	130	138	151	161	134	143	156	166
	MBh	57.1	58.2	61.0	65.0	55.8	56.9	59.6	63.5	54.5	55.5	58.1	62.0	53.1	54.2	56.7	60.5	50.5	51.4	53.9	57.5	46.7	47.7	49.9	53.2
	S/T	0.91	0.88	0.79	0.64	0.94	0.91	0.82	0.67	0.97	0.93	0.84	0.68	1.00	0.96	0.87	0.71	1.00	1.00	0.90	0.73	1.00	1.00	0.91	0.74
	ΔT	27	26	25	21	27	26	25	22	27	26	25	22	27	27	25	22	26	26	25	22	24	24	23	20
85	kW	4.12	4.20	4.33	4.46	4.42	4.51	4.65	4.79	4.69	4.78	4.93	5.09	4.92	5.02	5.18	5.35	5.12	5.23	5.39	5.57	5.29	5.40	5.58	5.76
	Amps	15.6	16.0	16.5	17.2	16.9	17.3	17.9	18.6	18.4	18.9	19.6	20.3	19.8	20.3	21.0	21.8	21.1	21.6	22.4	23.3	22.4	23.0	23.8	24.7
	Hi PR	232	250	264	275	261	281	296	309	297	319	337	351	338	363	384	400	380	409	432	450	420	452	477	498
	Lo PR	106	113	123	131	112	119	130	139	117	124	136	144	123	130	142	152	129	137	149	159	133	141	154	164
	MBh	52.7	53.7	56.3	60.0	51.5	52.5	55.0	58.6	50.3	51.2	53.7	57.2	49.0	50.0	52.3	55.8	46.6	47.5	49.7	53.1	43.1	44.0	46.1	49.1
	S/T	0.88	0.85	0.77	0.62	0.91	0.88	0.79	0.64	0.93	0.90	0.81	0.66	0.96	0.93	0.84	0.68	1.00	0.97	0.87	0.71	1.00	0.97	0.88	0.71
	ΔT	27	27	25	22	27	27	25	22	27	27	25	22	28	27	26	22	27	27	25	22	25	25	24	20
	kW	4.03	4.11	4.23	4.36	4.32	4.41	4.54	4.68	4.58	4.67	4.81	4.97	4.80	4.90	5.06	5.22	5.00	5.10	5.26	5.43	5.16	5.27	5.44	5.62
	Amps	15.1	15.5	16.1	16.7	16.4	16.8	17.4	18.1	17.9	18.4	19.0	19.7	19.2	19.7	20.4	21.2	20.5	21.0	21.7	22.6	21.7	22.3	23.1	24.0
	Hi PR	225	243	256	267	253	272	287	300	288	310	327	341	328	353	372	388	369	397	419	437	407	438	463	483
Lo PR	103	110	120	128	109	116	127	135	113	120	132	140	119	127	138	147	125	133	145	154	129	137	150	159	

IDB: Entering Indoor Dry Bulb Temperature
 High and low pressures are measured at the liquid and suction service valves.
 Shaded area reflects AHRI (TVA) conditions
 Amps = outdoor unit amps (compressor + fan)
 kW=Total system power

EXPANDED HEATING DATA

ASZ130181A* / AR*F182416**

	Outdoor Ambient Temperature																	
	65	60	55	50	47	45	40	35	30	25	20	17	15	10	5	0	-5	-10
MBh	21.4	20.2	19.0	17.8	17.0	16.5	15.3	14.1	12.5	11.5	10.6	10.0	9.6	8.6	7.7	6.7	5.7	4.7
ΔT	33.0	31.2	29.4	27.5	26.2	25.4	23.6	21.8	19.2	17.7	16.3	15.4	14.9	13.3	11.8	10.3	8.8	7.2
KW	1.68	1.65	1.61	1.58	1.6	1.54	1.51	1.47	1.42	1.38	1.35	1.33	1.32	1.28	1.25	1.22	1.18	1.15
Amps	8.7	8.1	7.6	7.2	7.0	6.8	6.5	6.2	5.9	5.7	5.5	5.3	5.3	5.0	4.7	4.5	4.2	3.8
COP	3.72	3.60	3.46	3.30	3.20	3.13	2.97	2.80	2.57	2.43	2.29	2.20	2.14	1.97	1.79	1.60	1.41	1.19
EER	12.7	12.3	11.8	11.3	10.9	10.7	10.1	9.6	8.8	8.3	7.8	7.5	7.3	6.7	6.1	5.5	4.8	4.1
HI PR	397	381	366	350	342	336	323	310	297	283	272	265	261	251	241	231	223	215
LO PR	145	134	126	115	109	105	96	86	77	69	61	57	55	46	40	34	29	23

ASZ130241A* / ARUF182416**

	Outdoor Ambient Temperature																	
	65	60	55	50	47	45	40	35	30	25	20	17	15	10	5	0	-5	-10
MBh	28.9	27.4	25.8	24.1	23.0	22.3	20.7	19.1	16.7	15.4	14.2	13.4	12.9	11.6	10.3	9.0	7.6	6.3
ΔT	32.6	30.9	29.1	27.2	26.0	25.2	23.4	21.6	18.9	17.4	16.0	15.1	14.6	13.1	11.6	10.1	8.6	7.1
KW	2.20	2.15	2.11	2.07	2.04	2.02	1.98	1.94	1.99	1.94	1.90	1.87	1.85	1.81	1.76	1.72	1.67	1.63
Amps	9.6	8.9	8.3	7.8	7.6	7.4	7.0	6.6	6.3	6.0	5.8	5.6	5.5	5.2	4.9	4.6	4.2	3.8
COP	3.85	3.72	3.57	3.41	3.29	3.22	3.05	2.88	2.46	2.32	2.19	2.10	2.04	1.88	1.71	1.53	1.34	1.13
EER	13.2	12.7	12.2	11.6	11.3	11.0	10.4	9.8	8.4	7.9	7.5	7.2	7.0	6.4	5.8	5.2	4.6	3.8
HI PR	411	394	379	362	354	347	334	320	307	293	281	275	270	259	250	239	231	223
LO PR	138	128	120	110	104	100	92	82	74	66	58	54	52	44	38	32	28	22

ASZ130301A* / AR*F303016**

	Outdoor Ambient Temperature																	
	65	60	55	50	47	45	40	35	30	25	20	17	15	10	5	0	-5	-10
MBh	33.2	31.4	29.6	27.6	26.4	25.6	23.8	21.9	19.9	18.4	16.9	16.0	15.4	13.8	12.3	10.7	9.1	7.5
ΔT	30.7	29.1	27.4	25.6	24.4	23.7	22.0	20.3	18.5	17.0	15.7	14.8	14.3	12.8	11.3	9.9	8.4	6.9
KW	2.52	2.47	2.42	2.37	2.35	2.32	2.28	2.23	2.37	2.32	2.26	2.23	2.21	2.16	2.11	2.05	2.00	1.95
Amps	11.0	10.2	9.5	8.9	8.6	8.4	7.9	7.5	7.2	6.9	6.5	6.4	6.3	6.0	5.6	5.2	4.8	4.3
COP	3.86	3.72	3.57	3.41	3.29	3.22	3.05	2.87	2.46	2.33	2.19	2.10	2.04	1.87	1.70	1.52	1.33	1.12
EER	13.2	12.7	12.2	11.6	11.3	11.0	10.4	9.8	8.4	7.9	7.5	7.2	7.0	6.4	5.8	5.2	4.6	3.8
HI PR	372	356	343	328	320	314	302	290	277	265	254	248	244	235	226	216	209	201
LO PR	133	123	115	106	100	96	89	79	71	64	56	52	50	42	37	31	27	21

High pressure is measured at the liquid service valve .
 Low pressure is measured at the gauge port connection.

kW = Total system power

Amps = Outdoor unit amps (comp.+fan)

Calculations are based on nominal CFM and 70 °F indoor dry bulb.

EXPANDED HEATING DATA (CONT.)

ASZ130361A* / AR*F364216**

	Outdoor Ambient Temperature																	
	65	60	55	50	47	45	40	35	30	25	20	17	15	10	5	0	-5	-10
MBh	42.7	40.5	38.1	35.6	34.0	32.9	30.6	28.2	24.9	23.0	21.2	20.0	19.3	17.3	15.3	13.4	11.4	9.3
ΔT	31.0	29.4	27.7	25.9	24.7	23.9	22.2	20.5	18.1	16.7	15.4	14.5	14.0	12.5	11.1	9.7	8.3	6.8
KW	3.15	3.09	3.03	2.97	2.93	2.90	2.84	2.78	2.83	2.77	2.70	2.66	2.64	2.57	2.51	2.44	2.38	2.31
Amps	14.7	13.6	12.7	12.0	11.5	11.3	10.7	10.1	9.7	9.2	8.8	8.6	8.5	8.0	7.5	7.0	6.5	5.8
COP	3.97	3.83	3.68	3.51	3.39	3.32	3.15	2.97	2.57	2.43	2.29	2.20	2.14	1.97	1.79	1.60	1.40	1.18
EER	13.5	13.1	12.6	12.0	11.6	11.3	10.8	10.1	8.8	8.3	7.8	7.5	7.3	6.7	6.1	5.5	4.8	4.0
HI PR	381	365	351	336	328	322	309	297	284	272	261	255	250	240	231	222	214	206
LO PR	133	123	115	106	100	96	89	79	71	64	56	52	50	42	37	31	27	21

ASZ130421A* / AR*F364216**

	Outdoor Ambient Temperature																	
	65	60	55	50	47	45	40	35	30	25	20	17	15	10	5	0	-5	-10
MBh	50.3	47.6	44.8	41.9	40.0	38.8	36.0	33.2	29.9	27.6	25.4	24.0	23.1	20.7	18.4	16.0	13.7	11.2
ΔT	33.3	31.5	29.6	27.7	26.5	25.6	23.8	22.0	19.8	18.3	16.8	15.9	15.3	13.7	12.2	10.6	9.0	7.4
KW	3.71	3.63	3.56	3.49	3.45	3.42	3.35	3.28	3.25	3.17	3.10	3.06	3.03	2.96	2.88	2.81	2.74	2.67
Amps	17.5	16.2	15.1	14.2	13.7	13.4	12.6	11.9	11.4	10.9	10.3	10.1	9.9	9.4	8.7	8.2	7.5	6.7
COP	3.97	3.83	3.68	3.51	3.40	3.32	3.15	2.97	2.70	2.55	2.40	2.30	2.23	2.05	1.87	1.67	1.46	1.23
EER	13.6	13.1	12.6	12.0	11.6	11.3	10.8	10.1	9.2	8.7	8.2	7.8	7.6	7.0	6.4	5.7	5.0	4.2
HI PR	372	356	343	328	320	314	302	290	277	265	254	248	244	235	226	216	209	201
LO PR	159	148	138	127	120	115	106	95	85	76	67	62	60	51	44	37	32	25

ASZ130481A* / AR*F486016**

	Outdoor Ambient Temperature																	
	65	60	55	50	47	45	40	35	30	25	20	17	15	10	5	0	-5	-10
MBh	55.3	52.4	49.3	46.1	44.0	42.6	39.6	36.5	33.6	31.1	28.6	27.0	26.0	23.3	20.7	18.0	15.4	12.6
ΔT	34.1	32.3	30.4	28.4	27.2	26.3	24.4	22.5	20.8	19.2	17.7	16.7	16.1	14.4	12.8	11.1	9.5	7.8
KW	3.95	3.87	3.80	3.72	3.68	3.65	3.58	3.50	3.50	3.42	3.34	3.30	3.27	3.19	3.11	3.04	2.96	2.88
Amps	18.4	17.0	15.9	14.9	14.4	14.1	13.3	12.6	12.0	11.5	10.9	10.6	10.5	9.9	9.2	8.6	8.0	7.1
COP	4.10	3.96	3.80	3.62	3.50	3.42	3.24	3.05	2.82	2.66	2.50	2.40	2.33	2.14	1.94	1.74	1.52	1.28
EER	14.0	13.5	13.0	12.4	12.0	11.7	11.1	10.4	9.6	9.1	8.6	8.2	8.0	7.3	6.6	5.9	5.2	4.4
HI PR	381	365	351	336	328	322	309	297	284	272	261	255	250	240	231	222	214	206
LO PR	129	119	112	103	97	93	86	76	69	62	54	50	49	41	35	30	26	20

ASZ130601A* / AR*F486016**

	Outdoor Ambient Temperature																	
	65	60	55	50	47	45	40	35	30	25	20	17	15	10	5	0	-5	-10
MBh	72.9	69.0	65.0	60.7	58.0	56.2	52.2	48.1	44.9	41.4	38.1	36.0	34.7	31.1	27.6	24.0	20.5	16.8
ΔT	37.5	35.5	33.4	31.2	29.8	28.9	26.9	24.8	23.1	21.3	19.6	18.5	17.8	16.0	14.2	12.4	10.6	8.6
KW	5.21	5.11	5.01	4.91	4.86	4.81	4.72	4.62	4.66	4.55	4.45	4.39	4.35	4.25	4.14	4.04	3.94	3.84
Amps	26.9	24.8	23.2	21.7	20.9	20.5	19.3	18.2	17.4	16.6	15.7	15.3	15.1	14.3	13.3	12.4	11.4	10.2
COP	4.09	3.95	3.79	3.62	3.49	3.42	3.24	3.05	2.82	2.66	2.51	2.40	2.33	2.14	1.95	1.74	1.52	1.28
EER	14.0	13.5	13.0	12.4	11.9	11.7	11.1	10.4	9.6	9.1	8.6	8.2	8.0	7.3	6.7	5.9	5.2	4.4
HI PR	429	411	395	378	369	362	348	334	320	306	293	286	281	270	260	249	241	232
LO PR	138	128	120	110	104	100	92	82	74	66	58	54	52	44	38	32	28	22

High pressure is measured at the liquid service valve .
 Low pressure is measured at the gauge port connection.

kW = Total system power

Amps = Outdoor unit amps (comp.+fan)
 Calculations are based on nominal CFM and 70 °F indoor dry bulb.

AHRI PERFORMANCE RATINGS

OUTDOOR UNIT	INDOOR UNITS		COOLING CAPACITY (BTU/H)				TVA RATINGS ³		HEATING CAPACITY (BTU/H)			AHRI #	
	COIL & AIR HANDLER	FURNACE/ BLOWER	TOTAL	SENS.	SEER ¹	EER ²	TOTAL	SENS.	HIGH	HSPF ⁴	LOW		
ASZ13 0181A*	ADPF182416B*		17,400	12,900	13	11	16,100	12,700	17,000	8	10,000	3186544	
	AEPF183016C*		17,800	13,200	14	11.5	16,500	13,000	17,000	8	10,000	3186546	
	AR*F182416B*		17,400	12,900	13	11	16,100	12,700	17,000	8	10,000	3186547	
	ASPF183016B*		17,800	13,200	14	11.5	16,500	13,000	17,000	8	10,000	3186548	
	AT*F182416A*		17,400	12,900	13	11	16,100	12,700	17,000	8	10,000	3186549	
	AWUF18XX16A*		17,400	12,900	13	11	16,100	12,700	17,000	8	10,000	3407745	
	AWUF18XX16B*		17,400	12,900	13	11	16,100	12,700	17,000	8	10,000	3570290	
	AWUF24XX16A*		17,400	12,900	13	11	16,100	12,700	17,000	8	10,000	3422859	
	AWUF24XX16B*		17,400	12,900	13	11	16,100	12,700	17,000	8	10,000	3620210	
	AWUF31XX16A*		17,400	12,900	14	11.5	16,100	12,700	17,500	8.4	10,000	3629355	
	CA*F1824*6B*	A*V80704B**		17,400	12,900	14	11.5	16,100	12,700	17,000	8	10,000	3186550
	CA*F1824*6B*	A*V90453B**		17,400	12,900	13.5	11	16,100	12,700	17,000	8	10,000	3186551
	CA*F1824*6B*	A*VC950453BXA*		17,400	12,900	13.5	11	16,100	12,700	17,000	8	10,000	3597161
	CA*F1824*6B*+EEP			17,400	12,900	13	11.5	16,100	12,700	17,000	7.8	10,000	3186552
	CA*F1824*6B*	MBE1200**-1		17,400	12,900	14	11.5	16,100	12,700	17,000	8	10,000	3186553
	CHPF1824A6B*+EEP			17,400	12,900	13	11.5	16,100	12,700	17,000	7.8	10,000	3186554
	CHPF1824A6C*+EEP			17,400	12,900	13	11.5	16,100	12,700	17,000	7.8	10,000	3299324
	CHPF2430B6B*	A*V80704B**		17,400	12,900	14	11.5	16,100	12,700	17,000	8	10,000	3186555
	CHPF2430B6B*	A*V90453B**		17,400	12,900	13.5	11.3	16,100	12,700	17,000	8	10,000	3186556
	CHPF2430B6B*	A*VC950453BXA*		17,400	12,900	13.5	11.3	16,100	12,700	17,000	8	10,000	3597162
	CHPF2430B6C*	A*V80704B**		17,400	12,900	14	11.5	16,100	12,700	17,000	8	10,000	3299325
	CHPF2430B6C*	A*V90453B**		17,400	12,900	13.5	11.3	16,100	12,700	17,000	8	10,000	3299326
	CHPF2430B6C*	A*VC950453BXA*		17,400	12,900	13.5	11.3	16,100	12,700	17,000	8	10,000	3597165
	CSCF1824N6B*	A*V80704B**		17,400	12,900	14	11.5	16,100	12,700	17,000	8	10,000	3186557
	CSCF1824N6B*	A*V90453B**		17,400	12,900	13.5	11.3	16,100	12,700	17,000	8	10,000	3186558
	CSCF1824N6B*	A*VC950453BXA*		17,400	12,900	13.5	11.3	16,100	12,700	17,000	8	10,000	3597163
	CSCF1824N6B*+EEP			17,400	12,900	13	11	16,100	12,700	17,000	7.8	10,000	3186559
	CT*F1824*6A*	A*V80704B**		17,400	12,900	14	11.5	16,100	12,700	17,000	8	10,000	3186560
	CT*F1824*6A*	A*V90453B**		17,400	12,900	13.5	11.5	16,100	12,700	17,000	8	10,000	3186561
	CT*F1824*6A*	A*V90704C**		17,400	12,900	13.5	11	16,100	12,700	17,000	8	10,000	3186562
	CT*F1824*6A*	A*VC90704CXA*		17,400	12,900	13.5	11	16,100	12,700	17,000	8	10,000	3597046
	CT*F1824*6A*	A*VC950453BXA*		17,400	12,900	13.5	11.5	16,100	12,700	17,000	8	10,000	3597164
CT*F1824*6A*	A*VC950704CXA*		17,400	12,900	13.5	11	16,100	12,700	17,000	8	10,000	3597217	
CT*F1824*6A*+EEP			17,400	12,900	13	11.5	16,100	12,700	17,000	7.8	10,000	3186563	
CT*F1824*6A*	MBE1200**-1		17,400	12,900	14	11.5	16,100	12,700	17,000	8	10,000	3186564	
ASZ13 0241A*	ADPF182416B*		23,000	17,000	13	11	21,300	16,800	23,000	8	13,400	3186565	
	AEPF183016C*		23,000	17,000	14	11.5	21,300	16,800	23,000	8.2	13,400	3635253	
	AR*F182416B*		23,000	17,000	13	11	21,300	16,800	23,000	8	13,400	3186567	
	ASPF183016B*		23,000	17,000	14	11.5	21,300	16,800	23,000	8.2	13,400	3186568	
	AT*F182416A*		23,000	17,000	13	11	21,300	16,800	23,000	8	13,400	3186569	
	AWUF24XX16A*		22,600	16,700	13	11	20,900	16,500	23,000	8	13,400	3422860	
	AWUF24XX16B*		22,600	16,700	13	11	20,900	16,500	23,000	8	13,400	3620211	
	AWUF30XX16B*		23,000	17,000	13	11	21,300	16,800	23,000	8	13,400	3422852	
	AWUF31XX16A*		23,000	17,000	14	11.5	21,300	16,800	23,800	8.3	14,000	3629356	
	AWUF32XX16A*		23,000	17,000	14	11.5	21,300	16,800	23,800	8.3	14,000	3629357	
	AWUF36XX16B*		23,000	17,000	13	11	21,300	16,800	23,000	8	13,400	3422853	
	CA*F1824*6B*	A*V80704B**		23,000	17,000	14	11.5	21,300	16,800	23,000	8.2	13,400	3186570
	CA*F1824*6B*	A*V90453B**		23,000	17,000	13.5	11.3	21,300	16,800	23,000	8	13,400	3186571

See Notes on Page 26.

AHRI PERFORMANCE RATINGS (CONT.)

OUTDOOR UNIT	INDOOR UNITS		COOLING CAPACITY (BTU/H)				TVA RATINGS ³		HEATING CAPACITY (BTU/H)			AHRI #
	COIL & AIR HANDLER	FURNACE/ BLOWER	TOTAL	SENS.	SEER ¹	EER ²	TOTAL	SENS.	HIGH	HSPF ⁴	LOW	
ASZ13 0241A* (cont.)	CA*F1824*6B*	A*VC950453BXA*	23,000	17,000	13.5	11.3	21,300	16,800	23,000	8	13,400	3597176
	CA*F1824*6B*+EEP		23,000	17,000	13	11	21,300	16,800	23,000	8	13,400	3186572
	CA*F1824*6B*	MBE1200** -1	23,000	17,000	14	11.5	21,300	16,800	23,000	8.2	13,400	3186573
	CHPF1824A6B*+EEP		23,000	17,000	13	11	21,300	16,800	23,000	8	13,400	3186574
	CHPF1824A6C*+EEP		23,000	17,000	13	11	21,300	16,800	23,000	8	13,400	3299336
	CHPF2430B6B*	A*V80704B**	23,000	17,000	14	12.2	21,300	16,800	23,000	8.2	13,400	3186575
	CHPF2430B6B*	A*V90453B**	23,000	17,000	13.5	11.3	21,300	16,800	23,000	8	13,400	3186576
	CHPF2430B6B*	A*VC950453BXA*	23,000	17,000	13.5	11.3	21,300	16,800	23,000	8	13,400	3597177
	CHPF2430B6B*	MBE1200** -1A*	23,000	17,000	14	11.5	21,300	16,800	23,000	8.2	13,400	3186577
	CHPF2430B6C*	A*V80704B**	23,000	17,000	14	12.2	21,300	16,800	23,000	8.2	13,400	3299337
	CHPF2430B6C*	A*V90453B**	23,000	17,000	13.5	11.3	21,300	16,800	23,000	8	13,400	3299338
	CHPF2430B6C*	A*VC950453BXA*	23,000	17,000	13.5	11.3	21,300	16,800	23,000	8	13,400	3597180
	CHPF2430B6C*	MBE1200** -1B*	23,000	17,000	14	11.5	21,300	16,800	23,000	8.2	13,400	3299339
	CSCF1824N6B*	A*V80704B**	23,000	17,000	14	11.5	21,300	16,800	23,000	8.2	13,400	3186578
	CSCF1824N6B*	A*V90453B**	23,000	17,000	13.5	11.3	21,300	16,800	23,000	8	13,400	3186579
	CSCF1824N6B*	A*VC950453BXA*	23,000	17,000	13.5	11.3	21,300	16,800	23,000	8	13,400	3597178
	CSCF1824N6B*+EEP		23,000	17,000	13	11	21,300	16,800	23,000	8	13,400	3186580
	CT*F1824*6A*	A*V80704B**	23,000	17,000	14	11.5	21,300	16,800	23,000	8.2	13,400	3186581
	CT*F1824*6A*	A*V90453B**	23,000	17,000	13.5	11.3	21,300	16,800	23,000	8	13,400	3186582
	CT*F1824*6A*	A*VC950453BXA*	23,000	17,000	13.5	11.3	21,300	16,800	23,000	8	13,400	3597179
CT*F1824*6A*+EEP		23,000	17,000	13	11	21,300	16,800	23,000	8	13,400	3186583	
CT*F1824*6A*	MBE1200** -1	23,000	17,000	14	11.5	21,300	16,800	23,000	8.2	13,400	3186584	
ASZ13 0301A*	ADPF304216B*		28,400	21,600	13	11	26,300	21,300	26,400	8	16,000	3186585
	AR*F182416B*+TXV		26,800	20,400	13	11	24,800	20,100	26,400	8.2	16,000	3186587
	AR*F303016B*		28,400	21,600	13	11	26,300	21,300	26,400	8	16,000	3186588
	ASPF183016B*		28,400	21,600	14	11.5	26,300	21,300	26,400	8.2	16,000	3186589
	AT*F182416A*+TXV		26,800	20,400	13	11	24,800	20,100	26,400	8.2	16,000	3186590
	AT*F303016A*		28,400	21,600	13	11	26,300	21,300	26,400	8	16,000	3186591
	AWUF30XX16B*		27,400	20,800	13	11	25,300	20,500	25,600	8	14,400	3422854
	AWUF36XX16B*		28,000	21,300	13	11	25,900	21,000	25,600	8	14,400	3422855
	AWUF37XX16B*		28,000	21,300	13	11	25,900	21,000	25,800	8	14,000	3422856
	CA*F3131*6B*	A*V80704B**	28,400	21,600	14	11.5	26,300	21,300	26,400	8.2	16,000	3186592
	CA*F3131*6B*	A*V90453B**	28,400	21,600	13.5	11.3	26,300	21,300	26,400	8	16,000	3186593
	CA*F3131*6B*	A*V90704C**	28,400	21,600	13.5	11.3	26,300	21,300	26,400	8	16,000	3186594
	CA*F3131*6B*	A*VC90704CXA*	28,400	21,600	13.5	11.3	26,300	21,300	26,400	8	16,000	3597056
	CA*F3131*6B*	A*VC950453BXA*	28,400	21,600	13.5	11.3	26,300	21,300	26,400	8	16,000	3597197
	CA*F3131*6B*	A*VC950704CXA*	28,400	21,600	13.5	11.3	26,300	21,300	26,400	8	16,000	3597227
	CA*F3131*6B*+EEP		28,400	21,600	13	11	26,300	21,300	26,400	8	16,000	3186595
	CA*F3131*6B*	MBE1200** -1	28,400	21,600	14	11.5	26,300	21,300	26,400	8.2	16,000	3186596
	CHPF2430B6B*	A*V80704B**	28,400	21,600	14	11.5	26,300	21,300	26,400	8.2	16,000	3186597
	CHPF2430B6B*	A*V90453B**	28,400	21,600	13.5	11.3	26,300	21,300	26,400	8	16,000	3186598
	CHPF2430B6B*	A*VC950453BXA*	28,400	21,600	13.5	11.3	26,300	21,300	26,400	8	16,000	3597198
	CHPF2430B6B*+EEP		28,400	21,600	13	11	26,300	21,300	26,400	8	16,000	3186599
	CHPF2430B6B*	MBE1200** -1A*	28,400	21,600	14	11.5	26,300	21,300	26,400	8.2	16,000	3186600
	CHPF2430B6C*	A*V80704B**	28,400	21,600	14	11.5	26,300	21,300	26,400	8.2	16,000	3299363
CHPF2430B6C*	A*V90453B**	28,400	21,600	13.5	11.3	26,300	21,300	26,400	8	16,000	3299364	
CHPF2430B6C*	A*VC950453BXA*	28,400	21,600	13.5	11.3	26,300	21,300	26,400	8	16,000	3597201	
CHPF2430B6C*+EEP		28,400	21,600	13	11	26,300	21,300	26,400	8	16,000	3299365	

See Notes on Page 26.

AHRI PERFORMANCE RATINGS (CONT.)

OUTDOOR UNIT	INDOOR UNITS		COOLING CAPACITY (BTU/H)				TVA RATINGS ³		HEATING CAPACITY (BTU/H)			AHRI #
	COIL & AIR HANDLER	FURNACE/ BLOWER	TOTAL	SENS.	SEER ¹	EER ²	TOTAL	SENS.	HIGH	HSPF ⁴	LOW	
ASZ13 0301A* (cont.)	CHPF2430B6C*	MBE1200**-1B*	28,400	21,600	14	11.5	26,300	21,300	26,400	8.2	16,000	3299366
	CSCF3036N6B*	A*V80704B**	28,400	21,600	14	11.5	26,300	21,300	26,400	8.2	16,000	3186601
	CSCF3036N6B*	A*V90453B**	28,400	21,600	13.5	11.3	26,300	21,300	26,400	8	16,000	3186602
	CSCF3036N6B*	A*VC950453BXA*	28,400	21,600	13.5	11.3	26,300	21,300	26,400	8	16,000	3597199
	CSCF3036N6B*+EEP		28,400	21,600	13	11	26,300	21,300	26,400	8	16,000	3186603
	CT*F3131*6A*	A*V80704B**	28,400	21,600	14	11.5	26,300	21,300	26,400	8.2	16,000	3186604
	CT*F3131*6A*	A*V90453B**	28,400	21,600	13.5	11.3	26,300	21,300	26,400	8	16,000	3186605
	CT*F3131*6A*	A*V90704C**	28,400	21,600	13.5	11.3	26,300	21,300	26,400	8	16,000	3186606
	CT*F3131*6A*	A*VC90704CXA*	28,400	21,600	13.5	11.3	26,300	21,300	26,400	8	16,000	3597057
	CT*F3131*6A*	A*VC950453BXA*	28,400	21,600	13.5	11.3	26,300	21,300	26,400	8	16,000	3597200
	CT*F3131*6A*	A*VC950704CXA*	28,400	21,600	13.5	11.3	26,300	21,300	26,400	8	16,000	3597228
	CT*F3131*6A*+EEP		28,400	21,600	13	11	26,300	21,300	26,400	8	16,000	3186607
	CT*F3131*6A*	MBE1200**-1	28,400	21,600	14	11.5	26,300	21,300	26,400	8.2	16,000	3186608
ASZ13 0361A*	ADPF304216B*		35,000	25,900	13	11	32,400	25,600	34,000	8	20,000	3186609
	AEPF303616C*		35,000	25,900	14	11.5	32,400	25,600	34,000	8.2	20,000	3186611
	AEPF313716A*		35,000	25,900	14	11.5	32,400	25,600	34,000	8.2	20,000	3323263
	AR*F363616B*		35,000	25,900	13	11	32,400	25,600	34,000	8	20,000	3186612
	AR*F364216B*		35,000	25,900	13	11	32,400	25,600	34,000	8	20,000	3186613
	ASPF303616B*		35,000	25,900	14	11.5	32,400	25,600	34,000	8.2	20,000	3186614
	ASPF313716A*		35,000	25,900	14	11.5	32,400	25,600	34,000	8.2	20,000	3323264
	AT*F363616A*		35,000	25,900	13	11	32,400	25,600	34,000	8	20,000	3186615
	AT*F364216A*		35,000	25,900	13	11	32,400	25,600	34,000	8	20,000	3186616
	AWUF37XX16B*		34,000	25,200	13	11	31,500	24,900	34,000	8	17,000	3422857
	CA*F3642*6B*	A*V80905C**	35,000	25,900	14	11.5	32,400	25,600	34,000	8.2	20,000	3186617
	CA*F3642*6B*	A*V81155C**	35,000	25,900	14	11.5	32,400	25,600	34,000	8.2	20,000	3186618
	CA*F3642*6B*	A*V90905D**	35,000	25,900	13.5	11.3	32,400	25,600	34,000	8	20,000	3186619
	CA*F3642*6B*	A*V91155D**	35,000	25,900	13.5	11.3	32,400	25,600	34,000	8	20,000	3186620
	CA*F3642*6B*	A*VC90905DXA*	35,000	25,900	13.5	11.3	32,400	25,600	34,000	8	20,000	3597100
	CA*F3642*6B*	A*VC950905DXA*	35,000	25,900	13.5	11.3	32,400	25,600	34,000	8	20,000	3597271
	CA*F3642*6B*	A*VC951155DXA*	35,000	25,900	13.5	11.3	32,400	25,600	34,000	8	20,000	3597346
	CA*F3642*6B*+EEP		35,000	25,900	13	11	32,400	25,600	34,000	7.8	20,000	3186621
	CA*F3642*6B*	MBE1600**-1	35,000	25,900	14	11.5	32,400	25,600	34,000	8.2	20,000	3186622
	CA*F3743*6A*	A*V80905C**	35,000	25,900	14	11.5	32,400	25,600	34,000	8.2	20,000	3186720
	CA*F3743*6A*	A*V81155C**	35,000	25,900	14	11.5	32,400	25,600	34,000	8.2	20,000	3186721
	CA*F3743*6A*	A*V90905D**	35,000	25,900	13.5	11.3	32,400	25,600	34,000	8	20,000	3186722
	CA*F3743*6A*	A*V91155D**	35,000	25,900	13.5	11.3	32,400	25,600	34,000	8	20,000	3186723
	CA*F3743*6A*	A*VC90905DXA*	35,000	25,900	13.5	11.3	32,400	25,600	34,000	8	20,000	3597104
	CA*F3743*6A*	A*VC950905DXA*	35,000	25,900	13.5	11.3	32,400	25,600	34,000	8	20,000	3597275
	CA*F3743*6A*	A*VC951155DXA*	35,000	25,900	13.5	11.3	32,400	25,600	34,000	8	20,000	3597350
	CA*F3743*6A*	A*VC81155CXA*	35,000	25,900	14	11.5	32,400	25,600	34,000	8.2	20,000	3642843
	CA*F3743*6A*	MBE1600**-1	35,000	25,900	14	11.5	32,400	25,600	34,000	8.2	20,000	3186724
	CHPF3636B6B*+EEP		35,000	25,900	13	11	32,400	25,600	34,000	7.8	20,000	3186623
	CHPF3636B6C*+EEP		35,000	25,900	13	11	32,400	25,600	34,000	7.8	20,000	3299383
	CHPF3642C6B*	A*V80905C**	35,000	25,900	14	11.5	32,400	25,600	34,000	8.2	20,000	3186624
CHPF3642C6B*	A*V81155C**	35,000	25,900	14	11.5	32,400	25,600	34,000	8.2	20,000	3186625	
CHPF3642C6B*+EEP		35,000	25,900	13	11	32,400	25,600	34,000	7.8	20,000	3186626	
CHPF3642C6B*	MBE1600**-1A*	35,000	25,900	14	11.5	32,400	25,600	34,000	8	20,000	3186627	
CHPF3642C6C*	A*V80905C**	35,000	25,900	14	11.5	32,400	25,600	34,000	8.2	20,000	3299384	

See Notes on Page 26.

AHRI PERFORMANCE RATINGS (CONT.)

OUTDOOR UNIT	INDOOR UNITS		COOLING CAPACITY (BTU/H)				TVA RATINGS ³		HEATING CAPACITY (BTU/H)			AHRI #
	COIL & AIR HANDLER	FURNACE/ BLOWER	TOTAL	SENS.	SEER ¹	EER ²	TOTAL	SENS.	HIGH	HSPF ⁴	LOW	
ASZ13 0361A* (cont.)	CHPF3642C6C*	A*V81155C**	35,000	25,900	14	11.5	32,400	25,600	34,000	8.2	20,000	3299385
	CHPF3642C6C*	A*VC81155CXA*	35,000	25,900	14	11.5	32,400	25,600	34,000	8.2	20,000	3642844
	CHPF3642C6C*+EEP		35,000	25,900	13	11	32,400	25,600	34,000	7.8	20,000	3299386
	CHPF3642C6C*	MBE1600**-.1B*	35,000	25,900	14	11.5	32,400	25,600	34,000	8	20,000	3299387
	CHPF3642D6B*	A*V90905D**	35,000	25,900	14	11.5	32,400	25,600	34,000	8.2	20,000	3186628
	CHPF3642D6B*	A*V91155D**	35,000	25,900	14	11.5	32,400	25,600	34,000	8.2	20,000	3186629
	CHPF3642D6B*	A*VC90905DXA*	35,000	25,900	14	11.5	32,400	25,600	34,000	8.2	20,000	3597101
	CHPF3642D6B*	A*VC950905DXA*	35,000	25,900	14	11.5	32,400	25,600	34,000	8.2	20,000	3597272
	CHPF3642D6B*	A*VC951155DXA*	35,000	25,900	14	11.5	32,400	25,600	34,000	8.2	20,000	3597347
	CHPF3642D6B*+EEP		35,000	25,900	13	11	32,400	25,600	34,000	7.8	20,000	3186630
	CHPF3642D6C*	A*V90905D**	35,000	25,900	14	11.5	32,400	25,600	34,000	8.2	20,000	3299388
	CHPF3642D6C*	A*V91155D**	35,000	25,900	14	11.5	32,400	25,600	34,000	8.2	20,000	3299389
	CHPF3642D6C*	A*VC90905DXA*	35,000	25,900	14	11.5	32,400	25,600	34,000	8.2	20,000	3597105
	CHPF3642D6C*	A*VC950905DXA*	35,000	25,900	14	11.5	32,400	25,600	34,000	8.2	20,000	3597276
	CHPF3642D6C*	A*VC951155DXA*	35,000	25,900	14	11.5	32,400	25,600	34,000	8.2	20,000	3597351
	CHPF3642D6C*+EEP		35,000	25,900	13	11	32,400	25,600	34,000	7.8	20,000	3299390
	CSCF3642N6C*	A*V80905C**	35,000	25,900	14	11.5	32,400	25,600	34,000	8.2	20,000	3186631
	CSCF3642N6C*	A*V81155C**	35,000	25,900	14	11.5	32,400	25,600	34,000	8.2	20,000	3186632
	CSCF3642N6C*	A*V90905D**	35,000	25,900	14	11.5	32,400	25,600	34,000	8.2	20,000	3186633
	CSCF3642N6C*	A*V91155D**	35,000	25,900	14	11.5	32,400	25,600	34,000	8.2	20,000	3186634
	CSCF3642N6C*	A*VC90905DXA*	35,000	25,900	14	11.5	32,400	25,600	34,000	8.2	20,000	3597102
	CSCF3642N6C*	A*VC950905DXA*	35,000	25,900	14	11.5	32,400	25,600	34,000	8.2	20,000	3597273
	CSCF3642N6C*	A*VC951155DXA*	35,000	25,900	14	11.5	32,400	25,600	34,000	8.2	20,000	3597348
	CSCF3642N6C*	A*VC81155CXA*	35,000	25,900	14	11.5	32,400	25,600	34,000	8.2	20,000	3642846
	CSCF3642N6C*+EEP		35,000	25,900	13	11	32,400	25,600	34,000	7.8	20,000	3186635
	CT*F3642*6A*	A*V80905C**	35,000	25,900	14	11.5	32,400	25,600	34,000	8.2	20,000	3186636
	CT*F3642*6A*	A*V81155C**	35,000	25,900	14	11.5	32,400	25,600	34,000	8.2	20,000	3186637
	CT*F3642*6A*	A*V90905D**	35,000	25,900	14	11.5	32,400	25,600	34,000	8.2	20,000	3186638
	CT*F3642*6A*	A*V91155D**	35,000	25,900	14	11.5	32,400	25,600	34,000	8.2	20,000	3186639
	CT*F3642*6A*	A*VC90905DXA*	35,000	25,900	14	11.5	32,400	25,600	34,000	8.2	20,000	3597103
CT*F3642*6A*	A*VC950905DXA*	35,000	25,900	14	11.5	32,400	25,600	34,000	8.2	20,000	3597274	
CT*F3642*6A*	A*VC951155DXA*	35,000	25,900	14	11.5	32,400	25,600	34,000	8.2	20,000	3597349	
CT*F3642*6A*	A*VC81155CXA*	35,000	25,900	14	11.5	32,400	25,600	34,000	8.2	20,000	3642847	
CT*F3642*6A*+EEP		35,000	25,900	13	11	32,400	25,600	34,000	7.8	20,000	3186640	
CT*F3642*6A*	MBE1600**-.1	35,000	25,900	14	11.5	32,400	25,600	34,000	8.2	20,000	3186641	
ASZ13 0421A*	ADPF304216B*		40,500	30,000	13	11	37,500	29,600	40,000	8	24,000	3186642
	AEPF426016C*		41,000	30,300	14	11.5	37,900	29,900	40,500	8.2	24,000	3595302
	AR*F364216B*		40,500	30,000	13	11	37,500	29,600	40,000	8	24,000	3186644
	ASPF426016B*		41,000	30,300	14	11.5	37,900	29,900	40,500	8.2	24,000	3186645
	AT*F364216A*		40,500	30,000	13	11	37,500	29,600	40,000	8	24,000	3186646
	CA*F3642*6B*+EEP		40,000	29,600	13	11	37,000	29,200	40,000	8	24,000	3186647
	CA*F4860*6B*	A*V80905C**	41,000	30,300	14	11.5	37,900	29,900	40,500	8.2	24,000	3186648
	CA*F4860*6B*	A*V81155C**	41,000	30,300	14	11.5	37,900	29,900	40,500	8.2	24,000	3186649
	CA*F4860*6B*	A*V90905D**	41,000	30,300	13.5	11.3	37,900	29,900	40,500	8	24,000	3186650
	CA*F4860*6B*	A*V91155D**	41,000	30,300	13.5	11.3	37,900	29,900	40,500	8	24,000	3186651
	CA*F4860*6B*	A*VC90905DXA*	41,000	30,300	13.5	11.3	37,900	29,900	40,500	8	24,000	3597124
	CA*F4860*6B*	A*VC950905DXA*	41,000	30,300	13.5	11.3	37,900	29,900	40,500	8	24,000	3597295
	CA*F4860*6B*	A*VC951155DXA*	41,000	30,300	13.5	11.3	37,900	29,900	40,500	8	24,000	3597370

See Notes on Page 26.

AHRI PERFORMANCE RATINGS (CONT.)

OUTDOOR UNIT	INDOOR UNITS		COOLING CAPACITY (BTU/H)				TVA RATINGS ³		HEATING CAPACITY (BTU/H)			AHRI #
	COIL & AIR HANDLER	FURNACE/ BLOWER	TOTAL	SENS.	SEER ¹	EER ²	TOTAL	SENS.	HIGH	HSPF ⁴	LOW	
ASZ13 0421A* (cont.)	CA*F4860*6B*	A*VC80905CXA*	41,000	30,300	14	11.5	37,900	29,900	40,500	8.2	24,000	3642859
	CHPF3642C6B*+EEP		40,500	30,000	13	11	37,500	29,600	40,000	8	24,000	3186652
	CHPF3642C6C*+EEP		40,500	30,000	13	11	37,500	29,600	40,000	8	24,000	3299445
	CHPF3642D6B*+EEP		40,500	30,000	13	11	37,500	29,600	40,000	8	24,000	3186653
	CHPF3642D6C*+EEP		40,500	30,000	13	11	37,500	29,600	40,000	8	24,000	3299446
	CHPF4860D6C*	A*V80905C**	41,000	30,300	14	11.5	37,900	29,900	40,500	8.2	24,000	3186654
	CHPF4860D6C*	A*V81155C**	41,000	30,300	14	11.5	37,900	29,900	40,500	8.2	24,000	3186655
	CHPF4860D6C*	A*V90905D**	41,000	30,300	13.5	11.3	37,900	29,900	40,500	8	24,000	3186656
	CHPF4860D6C*	A*V91155D**	41,000	30,300	13.5	11.3	37,900	29,900	40,500	8	24,000	3186657
	CHPF4860D6C*	A*VC90905DXA*	41,000	30,300	13.5	11.3	37,900	29,900	40,500	8	24,000	3597125
	CHPF4860D6C*	A*VC950905DXA*	41,000	30,300	13.5	11.3	37,900	29,900	40,500	8	24,000	3597296
	CHPF4860D6C*	A*VC951155DXA*	41,000	30,300	13.5	11.3	37,900	29,900	40,500	8	24,000	3597371
	CHPF4860D6C*	MBE1600**-1	41,000	30,300	14	11.5	37,900	29,900	40,500	8.2	24,000	3186658
	CHPF4860D6D*	A*V80905C**	41,000	30,300	14	11.5	37,900	29,900	40,500	8.2	24,000	3299447
	CHPF4860D6D*	A*V81155C**	41,000	30,300	14	11.5	37,900	29,900	40,500	8.2	24,000	3299448
	CHPF4860D6D*	A*V90905D**	41,000	30,300	13.5	11.3	37,900	29,900	40,500	8	24,000	3299449
	CHPF4860D6D*	A*V91155D**	41,000	30,300	13.5	11.3	37,900	29,900	40,500	8	24,000	3299450
	CHPF4860D6D*	A*VC90905DXA*	41,000	30,300	13.5	11.3	37,900	29,900	40,500	8	24,000	3597128
	CHPF4860D6D*	A*VC950905DXA*	41,000	30,300	13.5	11.3	37,900	29,900	40,500	8	24,000	3597299
	CHPF4860D6D*	A*VC951155DXA*	41,000	30,300	13.5	11.3	37,900	29,900	40,500	8	24,000	3597373
	CHPF4860D6D*	A*VC80905CXA*	41,000	30,300	14	11.5	37,900	29,900	40,500	8.2	24,000	3642860
	CHPF4860D6D*	MBE1600**-1B*	41,000	30,300	14	11.5	37,900	29,900	40,500	8.2	24,000	3299451
	CSCF3642N6C*+EEP		40,000	29,600	13	11	37,000	29,200	40,000	8	24,000	3186659
	CSCF4860N6C*	A*V80905C**	41,000	30,300	14	11.5	37,900	29,900	40,500	8.2	24,000	3186660
	CSCF4860N6C*	A*V81155C**	41,000	30,300	14	11.5	37,900	29,900	40,500	8.2	24,000	3186661
	CSCF4860N6C*	A*V90905D**	41,000	30,300	14	11.3	37,900	29,900	40,500	8	24,000	3186662
	CSCF4860N6C*	A*VC90905DXA*	41,000	30,300	14	11.3	37,900	29,900	40,500	8	24,000	3597126
	CSCF4860N6C*	A*VC950905DXA*	41,000	30,300	14	11.3	37,900	29,900	40,500	8	24,000	3597297
	CSCF4860N6C*	A*VC80905CXA*	41,000	30,300	14	11.5	37,900	29,900	40,500	8.2	24,000	3642862
	CT*F3642*6A*+EEP		40,000	29,600	13	11	37,000	29,200	40,000	8	24,000	3186664
	CT*F4860*6A*	A*V80905C**	41,000	30,300	14	11.5	37,900	29,900	40,500	8.2	24,000	3186665
	CT*F4860*6A*	A*V81155C**	41,000	30,300	14	11.5	37,900	29,900	40,500	8.2	24,000	3186666
CT*F4860*6A*	A*V90905D**	41,000	30,300	13.5	11.3	37,900	29,900	40,500	8	24,000	3186667	
CT*F4860*6A*	A*V91155D**	41,000	30,300	13.5	11.3	37,900	29,900	40,500	8	24,000	3186668	
CT*F4860*6A*	A*VC90905DXA*	41,000	30,300	13.5	11.3	37,900	29,900	40,500	8	24,000	3597127	
CT*F4860*6A*	A*VC950905DXA*	41,000	30,300	13.5	11.3	37,900	29,900	40,500	8	24,000	3597298	
CT*F4860*6A*	A*VC951155DXA*	41,000	30,300	13.5	11.3	37,900	29,900	40,500	8	24,000	3597372	
CT*F4860*6A*	A*VC80905CXA*	41,000	30,300	14	11.5	37,900	29,900	40,500	8.2	24,000	3642863	
CT*F4860*6A*	MBE1600**-1	41,000	30,300	14	11.5	37,900	29,900	40,500	8.2	24,000	3186669	
ASZ13 0481A*	ADPF486016B*		46,000	35,000	13	11	42,600	34,500	44,000	8.2	27,000	3186670
	AEPF426016C*+TXV		46,000	35,000	14	11.5	42,600	34,500	44,000	8.4	27,000	3595303
	AR*F486016B*		46,000	35,000	13	11	42,600	34,500	44,000	8.2	27,000	3186672
	ASPF426016B*+TXV		46,000	35,000	14	11.5	42,600	34,500	44,000	8.4	27,000	3186673
	AT*F486016A*		46,000	35,000	13	11	42,600	34,500	44,000	8.2	27,000	3186674
	CA*F4860*6B*+EEP		46,000	35,000	13	11	42,600	34,500	44,000	8.2	27,000	3186675
	CA*F4860*6B*+TXV	MBE2000**-1	46,000	35,000	14	11.5	42,600	34,500	44,000	8.4	27,000	3186676

See Notes on Page 26.

AHRI PERFORMANCE RATINGS (CONT.)

OUTDOOR UNIT	INDOOR UNITS		COOLING CAPACITY (BTU/H)				TVA RATINGS ³		HEATING CAPACITY (BTU/H)			AHRI #
	COIL & AIR HANDLER	FURNACE/ BLOWER	TOTAL	SENS.	SEER ¹	EER ²	TOTAL	SENS.	HIGH	HSPF ⁴	LOW	
ASZ13 0481A* (cont.)	CA*F4860*6B*+TXV	A*V80905C**	46,000	35,000	14	11.5	42,600	34,500	44,000	8.4	27,000	3186677
	CA*F4860*6B*+TXV	A*V81155C**	46,000	35,000	14	11.5	42,600	34,500	44,000	8.4	27,000	3186678
	CA*F4860*6B*+TXV	A*V90905D**	46,000	35,000	14	11.5	42,600	34,500	44,000	8.4	27,000	3186679
	CA*F4860*6B*+TXV	A*V91155D**	46,000	35,000	14	11.5	42,600	34,500	44,000	8.4	27,000	3186680
	CA*F4860*6B*+TXV	A*VC90905DXA*	46,000	35,000	14	11.5	42,600	34,500	44,000	8.4	27,000	3597133
	CA*F4860*6B*+TXV	A*VC950905DXA*	46,000	35,000	14	11.5	42,600	34,500	44,000	8.4	27,000	3597304
	CA*F4860*6B*+TXV	A*VC951155DXA*	46,000	35,000	14	11.5	42,600	34,500	44,000	8.4	27,000	3597378
	CA*F4860*6B*+TXV	A*VC80905CXA*	46,000	35,000	14	11.5	42,600	34,500	44,000	8.4	27,000	3642868
	CHPF4860D6C*+EEP		46,000	35,000	13	11.3	42,600	34,500	44,000	8.3	27,000	3186681
	CHPF4860D6C*+TXV	MBE2000**-1A*	46,000	35,000	14	11.5	42,600	34,500	44,000	8.4	27,000	3186682
	CHPF4860D6C*+TXV	A*V80905C**	46,000	35,000	14	11.5	42,600	34,500	44,000	8.4	27,000	3186683
	CHPF4860D6C*+TXV	A*V81155C**	46,000	35,000	14	11.5	42,600	34,500	44,000	8.4	27,000	3186684
	CHPF4860D6C*+TXV	A*V90905D**	46,000	35,000	14	11.5	42,600	34,500	44,000	8.4	27,000	3186685
	CHPF4860D6C*+TXV	A*V91155D**	46,000	35,000	14	11.5	42,600	34,500	44,000	8.4	27,000	3186686
	CHPF4860D6C*+TXV	A*VC90905DXA*	46,000	35,000	14	11.5	42,600	34,500	44,000	8.4	27,000	3597134
	CHPF4860D6C*+TXV	A*VC950905DXA*	46,000	35,000	14	11.5	42,600	34,500	44,000	8.4	27,000	3597305
	CHPF4860D6C*+TXV	A*VC951155DXA*	46,000	35,000	14	11.5	42,600	34,500	44,000	8.4	27,000	3597379
	CHPF4860D6D*+EEP		46,000	35,000	13	11.3	42,600	34,500	44,000	8.3	27,000	3299462
	CHPF4860D6D*+TXV	MBE2000**-1B*	46,000	35,000	14	11.5	42,600	34,500	44,000	8.4	27,000	3299463
	CHPF4860D6D*+TXV	A*V80905C**	46,000	35,000	14	11.5	42,600	34,500	44,000	8.4	27,000	3299464
	CHPF4860D6D*+TXV	A*V81155C**	46,000	35,000	14	11.5	42,600	34,500	44,000	8.4	27,000	3299465
	CHPF4860D6D*+TXV	A*V90905D**	46,000	35,000	14	11.5	42,600	34,500	44,000	8.4	27,000	3299466
	CHPF4860D6D*+TXV	A*V91155D**	46,000	35,000	14	11.5	42,600	34,500	44,000	8.4	27,000	3299467
	CHPF4860D6D*+TXV	A*VC90905DXA*	46,000	35,000	14	11.5	42,600	34,500	44,000	8.4	27,000	3597137
	CHPF4860D6D*+TXV	A*VC950905DXA*	46,000	35,000	14	11.5	42,600	34,500	44,000	8.4	27,000	3597308
	CHPF4860D6D*+TXV	A*VC951155DXA*	46,000	35,000	14	11.5	42,600	34,500	44,000	8.4	27,000	3597382
	CHPF4860D6D*+TXV	A*VC80905CXA*	46,000	35,000	14	11.5	42,600	34,500	44,000	8.4	27,000	3642869
	CSCF4860N6C*+EEP		46,000	35,000	13	11.3	42,600	34,500	44,000	8.3	27,000	3186687
	CSCF4860N6C*+TXV	A*V80905C**	46,000	35,000	14	11.3	42,600	34,500	44,000	8.3	27,000	3186688
	CSCF4860N6C*+TXV	A*V81155C**	46,000	35,000	14	11	42,600	34,500	44,000	8.2	27,000	3186689
	CSCF4860N6C*+TXV	A*V90905D**	46,000	35,000	14	11.3	42,600	34,500	44,000	8.3	27,000	3186690
	CSCF4860N6C*+TXV	A*V91155D**	46,000	35,000	14	11.3	42,600	34,500	44,000	8.3	27,000	3186691
	CSCF4860N6C*+TXV	A*VC90905DXA*	46,000	35,000	14	11.3	42,600	34,500	44,000	8.3	27,000	3597135
	CSCF4860N6C*+TXV	A*VC950905DXA*	46,000	35,000	14	11.3	42,600	34,500	44,000	8.3	27,000	3597306
	CSCF4860N6C*+TXV	A*VC951155DXA*	46,000	35,000	14	11.3	42,600	34,500	44,000	8.3	27,000	3597380
	CSCF4860N6C*+TXV	A*VC80905CXA*	46,000	35,000	14	11.3	42,600	34,500	44,000	8.3	27,000	3642871
	CT*F4860*6A*+EEP		46,000	35,000	13	11	42,600	34,500	44,000	8.2	27,000	3186692
	CT*F4860*6A*+TXV	MBE2000**-1	46,000	35,000	14	11.5	42,600	34,500	44,000	8.4	27,000	3186693
	CT*F4860*6A*+TXV	A*V80905C**	46,000	35,000	14	11.5	42,600	34,500	44,000	8.4	27,000	3186694
	CT*F4860*6A*+TXV	A*V81155C**	46,000	35,000	14	11.5	42,600	34,500	44,000	8.4	27,000	3186695
CT*F4860*6A*+TXV	A*V90905D**	46,000	35,000	14	11.5	42,600	34,500	44,000	8.4	27,000	3186696	
CT*F4860*6A*+TXV	A*V91155D**	46,000	35,000	14	11.5	42,600	34,500	44,000	8.4	27,000	3186697	
CT*F4860*6A*+TXV	A*VC90905DXA*	46,000	35,000	14	11.5	42,600	34,500	44,000	8.4	27,000	3597136	
CT*F4860*6A*+TXV	A*VC950905DXA*	46,000	35,000	14	11.5	42,600	34,500	44,000	8.4	27,000	3597307	
CT*F4860*6A*+TXV	A*VC951155DXA*	46,000	35,000	14	11.5	42,600	34,500	44,000	8.4	27,000	3597381	
CT*F4860*6A*+TXV	A*VC80905CXA*	46,000	35,000	14	11.5	42,600	34,500	44,000	8.4	27,000	3642872	

See Notes on Page 26.

AHRI PERFORMANCE RATINGS (CONT.)

OUTDOOR UNIT	INDOOR UNITS		COOLING CAPACITY (BTU/H)				TVA RATINGS ³		HEATING CAPACITY (BTU/H)			AHRI #
	COIL & AIR HANDLER	FURNACE/ BLOWER	TOTAL	SENS.	SEER ¹	EER ²	TOTAL	SENS.	HIGH	HSPF ⁴	LOW	
ASZ13 0601A*	ADPF486016B*		57,000	42,800	13	11.1	52,700	42,200	58,000	8.4	36,000	3186698
	AEPF426016C*+TXV		57,000	42,800	13.5	11.2	52,700	42,200	58,000	8.6	36,000	3595304
	AR*F486016B*		57,000	42,800	13	11.1	52,700	42,200	58,000	8.4	36,000	3186700
	ASPF426016B*+TXV		57,000	42,800	13.5	11.2	52,700	42,200	58,000	8.6	36,000	3186701
	AT*F486016A*		57,000	42,800	13	11.1	52,700	42,200	58,000	8.4	36,000	3186702
	CA*F4860*6B*+EEP		57,000	42,800	13	11.1	52,700	42,200	58,000	8.4	36,000	3186703
	CA*F4860*6B*+TXV	MBE2000** -1	57,000	42,800	13.5	11.3	52,700	42,200	58,000	8.6	36,000	3186704
	CA*F4860*6B*+TXV	A*V80905C**	57,000	42,800	13.3	11.2	52,700	42,200	58,000	8.4	36,000	3186705
	CA*F4860*6B*+TXV	A*V81155C**	57,000	42,800	13.3	11.2	52,700	42,200	58,000	8.4	36,000	3186706
	CHPF4860D6C*+EEP		57,000	42,800	13	11.1	52,700	42,200	58,000	8.4	36,000	3186707
	CHPF4860D6C*+TXV	MBE2000** -1A*	57,000	42,800	13.5	11.3	52,700	42,200	58,000	8.6	36,000	3186708
	CHPF4860D6C*+TXV	A*V80905C**	57,000	42,800	13.3	11.2	52,700	42,200	58,000	8.4	36,000	3186709
	CHPF4860D6C*+TXV	A*V81155C**	57,000	42,800	13.3	11.2	52,700	42,200	58,000	8.4	36,000	3186710
	CHPF4860D6D*+EEP		57,000	42,800	13	11.1	52,700	42,200	58,000	8.4	36,000	3299488
	CHPF4860D6D*+TXV	MBE2000** -1B*	57,000	42,800	13.5	11.3	52,700	42,200	58,000	8.6	36,000	3299489
	CHPF4860D6D*+TXV	A*V80905C**	57,000	42,800	13.3	11.2	52,700	42,200	58,000	8.4	36,000	3299490
	CHPF4860D6D*+TXV	A*V81155C**	57,000	42,800	13.3	11.2	52,700	42,200	58,000	8.4	36,000	3299491
	CSCF4860N6C*+EEP		57,000	42,800	13	11.1	52,700	42,200	58,000	8.4	36,000	3186711
	CSCF4860N6C*+TXV	A*V80905C**	57,000	42,800	13.3	11.2	52,700	42,200	58,000	8.4	36,000	3186712
	CSCF4860N6C*+TXV	A*V81155C**	57,000	42,800	13.3	11.2	52,700	42,200	58,000	8.4	36,000	3186713
	CSCF4860N6C*+TXV	A*V90905D**	57,000	42,800	13.3	11.2	52,700	42,200	58,000	8.4	36,000	3186714
	CSCF4860N6C*+TXV	A*V91155D**	57,000	42,800	13.3	11.2	52,700	42,200	58,000	8.4	36,000	3186715
	CSCF4860N6C*+TXV	A*VC90905DXA*	57,000	42,800	13.3	11.2	52,700	42,200	58,000	8.4	36,000	3597152
	CSCF4860N6C*+TXV	A*VC950905DXA*	57,000	42,800	13.3	11.2	52,700	42,200	58,000	8.4	36,000	3597323
	CSCF4860N6C*+TXV	A*VC951155DXA*	57,000	42,800	13.3	11.2	52,700	42,200	58,000	8.4	36,000	3597403
	CT*F4860*6A*+EEP		57,000	42,800	13	11.1	52,700	42,200	58,000	8.4	36,000	3186716
	CT*F4860*6A*+TXV	MBE2000** -1	57,000	42,800	13.5	11.3	52,700	42,200	58,000	8.6	36,000	3186717
	CT*F4860*6A*+TXV	A*V80905C**	57,000	42,800	13.3	11.2	52,700	42,200	58,000	8.4	36,000	3186718
CT*F4860*6A*+TXV	A*V81155C**	57,000	42,800	13.3	11.2	52,700	42,200	58,000	8.4	36,000	3186719	

¹ Seasonal Energy Efficiency Ratio; Certified per ARI 210/240 @ 80°F/ 67°F/ 95°F

² Energy Efficiency Ratio @ 80°F/ 67°F/ 95°F

³ TVA Rating: BTU/h @ 75°F/ 63°F - 95°F

⁴ HSPF = Heating Seasonal Performance Factor

Notes:

- ° Always check the S&R plate for electrical data on the unit being installed.
- ° When matching outdoor unit to indoor unit, use the piston supplied with the outdoor unit or that specified on the piston kit chart supplied with the indoor unit.
- ° EEP - Order from Service Dept. Part No. B13707-38 or new Solid State Board B13707-35S. Part No. B13707-38 is not interchangeable with B13707-35S. The Goodman Gas Furnace contains the EEP cooling time delay

WIRING DIAGRAM

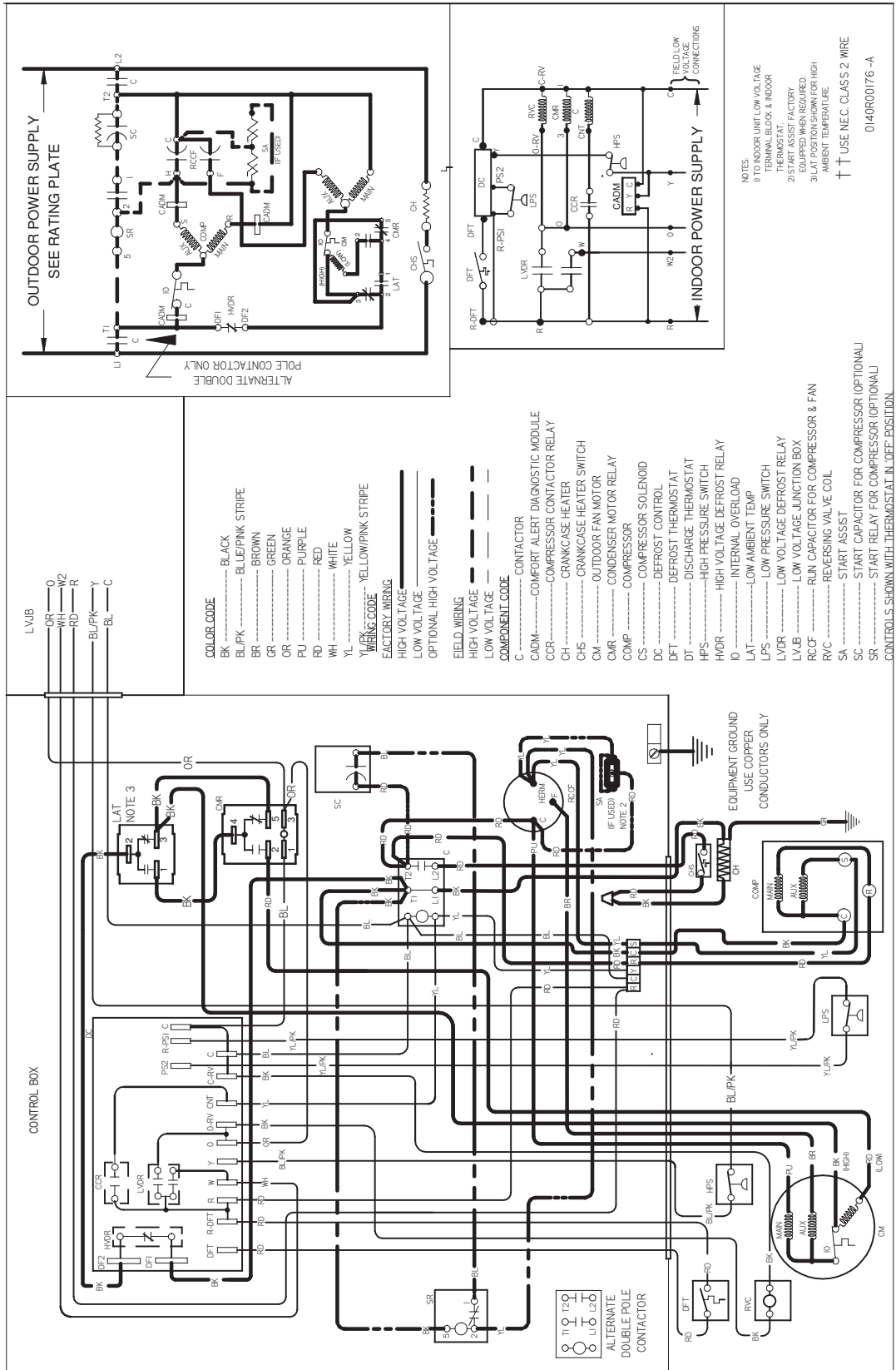

WARNING High Voltage: Disconnect all power before servicing or installing this unit. Multiple power sources may be present. Failure to do so may cause property damage, personal injury, or death.

Wiring is subject to change. Always refer to the wiring diagram or the unit for the most up-to-date wiring.

DIMENSIONS

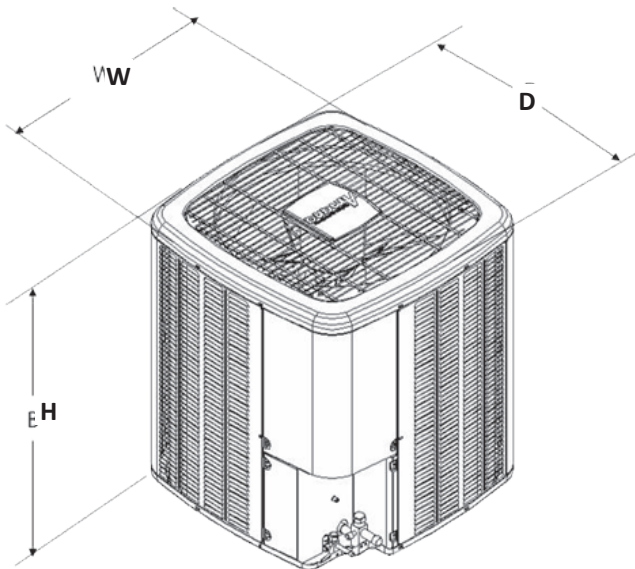

MODEL	DIMENSIONS		
	W"	D"	H"
ASZ130181A*	26	26	32½
ASZ130241A*	26	26	32½
ASZ130301A*	26	26	32½
ASZ130361A*	29	29	38½
ASZ130421A*	29	29	38½
ASZ130481A*	29	29	34½
ASZ130601A*	35½	35½	34½

ACCESSORIES

MODEL #	DESCRIPTION	ASZ13 0181	ASZ13 024	ASZ13 030	ASZ13 036	ASZ13 042	ASZ13 048	ASZ13 060
ABK-20	Anchor Bracket Kit [◊]	X	X	X	X	X	X	X
AFE18-60A	All-Fuel Kit	X	X	X	X	X	X	X
ASC01	Anti-Short Cycle Kit	X	X	X	X	X	X	X
CSR-U-1	Hard-Start Kit	X	X	X	X			
CSR-U-2	Hard-Start Kit				X	X	X	X
CSR-U-3	Hard-Start Kit						X	X
FSK01A1	Freeze Protection Kit	X	X	X	X	X	X	X
OT/EHR18-60	Emergency Heat Relay Kit	X	X	X	X	X	X	X
OT18-60A ²	Outdoor Thermostat w/ Lockout Stat	X	X	X	X	X	X	X
TX2N4 ³	TXV Kit	X						
TX3N4 ³	TXV Kit		X	X	X			
TX5N4 ³	TXV Kit					X	X	X

[◊] Contains 20 brackets; four brackets needed to anchor unit to pad

¹ Installed on indoor coil

² Required for heat pump applications where ambient temperatures fall below 0°F with 50% or higher relative humidity.

³ Field-installed, non-bleed, expansion valve kit — Condensing units and heat pumps with reciprocating compressors require the use of start-assist components when used in conjunction with an indoor coil using a non-bleed thermal expansion valve refrigerant metering device or liquid line solenoid kit.

