



## PRODUCT SPECIFICATIONS



**UP TO 18 SEER**

**R-410A**

**COOLING CAPACITY: 35,000 - 56,500 BTU/H**

**HEATING CAPACITY: 33,600 - 56,400 BTU/H**



\* To receive the Lifetime Unit Replacement Limited Warranty and 10-Year Parts Limited Warranty, online registration must be completed within 60 days of installation. Online registration is not required in California or Québec. Full warranty details are available at [www.amana-hac.com](http://www.amana-hac.com).

# ASZC18

## SPLIT SYSTEM HEAT PUMP

The Amana® brand ASZC18 Heat Pump uses the chlorine-free R-410A refrigerant and is part of our new ComfortNet™ family of communicating units. In addition, the ASZC18 contains the two-stage, high-efficiency Copeland® scroll compressor, which provides improved temperature and humidity control. This unit is designed for the consumer who desires superb comfort and quiet operation.

### Standard Features

- R-410A chlorine-free refrigerant
- Two-Stage Copeland UltraTech scroll compressor
- High-density foam compressor sound blanket
- ComfortNet™ Communications System compatible
- Expanded ComfortAlert diagnostics built in
- Set-up capable with 2 low-voltage wires to outdoor unit
- Diagnostic indicator lights and storage of 6 fault codes
- Color-coded terminal strip for non-communicating set-up
- High- and low-pressure switches
- Fully charged for 15' of tubing length
- Factory-installed filter dryer
- Coil and ambient temperature sensors
- Two-speed, quiet condenser fan motor
- Sweat connection service valves with easy access to gauge ports
- AHRI Certified; ETL Listed

### Cabinet Features

- Amana brand sound control top design
- Wire fan discharge grille
- Steel louver coil guard
- Baked-on powder paint finish
- Rust-resistant coated screws
- Compact footprint
- Top and side maintenance access
- Single panel access to controls with space provided for field-installed accessories
- When properly anchored, meets the 2001 Florida Building Code unit integrity requirements for hurricane-type winds (Anchor bracket kits available.)

### Contents

Nomenclature.....	2
Product Specifications.....	3
Expanded Cooling Data.....	4
Expanded Heating Data.....	16
AHRI Performance Ratings.....	18
Wiring Diagram.....	23
Dimensions.....	24
Accessories.....	24

# NOMENCLATURE

	A	S	Z	C	18	036	1	A	A		
	1	2	3	4	5,6	7,8,9	10	11	12		
<b>Brand</b>	A Amana® Brand							<b>Engineering *</b>			
								Minor Revision			
<b>Product Category</b>	S Split System									<b>Engineering *</b>	
										Major Revision	
<b>Unit Type</b>	X Condenser R-410A			Z Heat Pump R-410A							<b>Electrical</b>
							1 208/230 V, 1 Phase, 60 Hz				
							2 220/240 V, 1 Phase, 50 Hz				
							3 208/230 V, 3 Phase, 60 Hz				
							4 460 V, 3 Phase, 60 Hz				
							5 380/415 V, 3 Phase, 50 Hz				
<b>Communication Feature</b>	C ComfortNet 4-wire communications ready										
<b>Efficiency</b>	13 13 SEER		16 16 SEER						<b>Nominal Capacity</b>		
	14 14 SEER		18 18 SEER		024 2 Tons		048 4 Tons				
					036 3 Tons		060 5 Tons				

\* Neither used for order entry or inventory management.

**Important EnergyStar Notice:** EnergyStar ratings are dependent upon conditions beyond equipment installation. Proper sizing and installation of equipment is critical to achieve optimal performance. Split system air conditioners and heat pumps must be matched with appropriate coil components to meet EnergyStar criteria. Ask your contractor for details or visit [www.energystar.gov](http://www.energystar.gov).

# SPECIFICATIONS

	ASZC18 0361A	ASZC18 0481A	ASZC18 0601A
<b>Cooling Capacity</b>			
Nominal Cooling (BTU/h)	35,000	47,000	57,000
Nominal Heating (BTU/h)	35,000	47,000	57,000
Decibels	72	73	75
<b>Compressor</b>			
RLA	16.7	21.2	25.6
LRA	82	96	118
<b>Condenser Fan Motor</b>			
Horsepower (RPM)	1/3	1/3	1/3
FLA	2.80	2.80	2.80
<b>Refrigeration System</b>			
Refrigerant Line Size <sup>1</sup>			
Liquid Line Size ("O.D.)	3/8"	3/8"	3/8"
Suction Line Size ("O.D.)	7/8"	1 1/8"	1 1/8"
Refrigerant Connection Size			
Liquid Valve Size ("O.D.)	3/8"	3/8"	3/8"
Suction Valve Size ("O.D.)	7/8"	1 1/8"	1 1/8"
Valve Connection Type	Sweat	Sweat	Sweat
Refrigerant Charge	188	278	278
Expansion Device	TXV	TXV	TXV
Superheat at Service Valve	5-7°F	5-7°F	5-7°F
Subcooling at Service Valve	8-10°F	8-10°F	8-10°F
<b>Electrical Data</b>			
Voltage-Phase-Hz	208/230-1-60	208/230-1-60	208/230-1-60
Minimum Circuit Ampacity <sup>2</sup>	23.7	29.3	34.8
Max. Overcurrent Protection <sup>3</sup>	40 amps	50 amps	60 amps
Min / Max Volts	197 / 253	197 / 253	197 / 253
Electrical Conduit Size	1/2" or 3/4"	1/2" or 3/4"	1/2" or 3/4"
<b>Ship Weight (lbs)</b>	285	330	350

<sup>1</sup> Tested and rated in accordance with ARI Standard 210/240

<sup>2</sup> Wire size should be determined in accordance with National Electrical Codes; extensive wire runs will require larger wire sizes

<sup>3</sup> Must use time-delay fuses or HACR-type circuit breakers of the same size as noted.

**NOTES**

- Always check the S&R plate for electrical data on the unit being installed.
- Installer will need to supply 7/8" to 1 1/8" adapters for suction line connections.
- Unit is charged with refrigerant for 15' of 3/8" liquid line. System charge must be adjusted per Installation Instructions Final Charge Procedure.
- Installation of these units requires the specified TXV Kit to be installed on the indoor coil. THE SPECIFIED TXV IS DETERMINED BY THE OUTDOOR UNIT, NOT THE INDOOR COIL.

EXPANDED COOLING DATA — ASZC180361A\*/CA\*F3743\*6\*\*+TXV/MBVC1600\*\* LOW STAGE

IDB	AIRFLOW	OUTDOOR AMBIENT TEMPERATURE																							
		65°F				75°F				85°F				95°F				105°F				115°F			
		59	63	67	71	59	63	67	71	59	63	67	71	59	63	67	71	59	63	67	71	59	63	67	71
70	MBh	24.8	25.7	28.1	-	24.2	25.1	27.5	-	23.6	24.5	26.8	-	23.1	23.9	26.2	-	21.9	22.7	24.9	-	20.3	21.0	23.0	-
	S/T	0.77	0.64	0.44	-	0.79	0.66	0.46	-	0.81	0.68	0.47	-	0.84	0.70	0.49	-	0.87	0.73	0.50	-	0.88	0.73	0.51	-
	ΔT	18	16	12	-	18	16	12	-	18	16	12	-	19	16	12	-	18	16	12	-	17	15	11	-
	kW	1.34	1.37	1.42	-	1.45	1.48	1.54	-	1.55	1.58	1.64	-	1.63	1.67	1.73	-	1.71	1.75	1.81	-	1.77	1.81	1.88	-
	Amps	5.3	5.4	5.6	-	5.7	5.9	6.1	-	6.2	6.4	6.6	-	6.7	6.8	7.1	-	7.1	7.3	7.5	-	7.5	7.7	8.0	-
	Hi PR	209	225	237	-	234	252	266	-	267	287	303	-	304	327	345	-	342	368	388	-	377	406	429	-
	Lo PR	111	118	128	-	117	124	136	-	121	129	141	-	128	136	148	-	134	142	155	-	138	147	161	-
	MBh	24.1	24.9	27.3	-	23.5	24.4	26.7	-	22.9	23.8	26.1	-	22.4	23.2	25.4	-	21.3	22.0	24.1	-	19.7	20.4	22.4	-
	S/T	0.73	0.61	0.42	-	0.76	0.63	0.44	-	0.78	0.65	0.45	-	0.80	0.67	0.46	-	0.83	0.69	0.48	-	0.84	0.70	0.48	-
	ΔT	19	16	12	-	19	17	13	-	19	17	13	-	19	17	13	-	19	17	13	-	18	15	12	-
kW	1.33	1.36	1.40	-	1.44	1.47	1.52	-	1.54	1.57	1.63	-	1.62	1.66	1.72	-	1.69	1.73	1.79	-	1.76	1.80	1.86	-	
Amps	5.3	5.4	5.6	-	5.7	5.8	6.0	-	6.2	6.3	6.5	-	6.6	6.8	7.0	-	7.0	7.2	7.5	-	7.5	7.6	7.9	-	
Hi PR	207	223	235	-	232	250	264	-	264	284	300	-	301	324	342	-	338	364	384	-	374	402	425	-	
Lo PR	110	117	127	-	116	123	134	-	120	128	140	-	126	134	147	-	132	141	154	-	137	146	159	-	
MBh	22.2	23.0	25.2	-	21.7	22.5	24.6	-	21.2	21.9	24.0	-	20.7	21.4	23.5	-	19.6	20.3	22.3	-	18.2	18.8	20.6	-	
S/T	0.70	0.59	0.41	-	0.73	0.61	0.42	-	0.75	0.62	0.43	-	0.77	0.64	0.45	-	0.80	0.67	0.46	-	0.81	0.67	0.47	-	
ΔT	19	17	13	-	20	17	13	-	20	17	13	-	20	17	13	-	19	17	13	-	18	16	12	-	
kW	1.29	1.32	1.37	-	1.40	1.43	1.48	-	1.50	1.53	1.58	-	1.58	1.61	1.67	-	1.65	1.69	1.75	-	1.71	1.75	1.81	-	
Amps	5.1	5.2	5.4	-	5.5	5.7	5.9	-	6.0	6.2	6.4	-	6.4	6.6	6.8	-	6.8	7.0	7.2	-	7.2	7.4	7.7	-	
Hi PR	201	216	228	-	225	242	256	-	256	276	291	-	292	314	331	-	328	353	373	-	363	390	412	-	
Lo PR	106	113	123	-	112	119	130	-	117	124	135	-	123	130	142	-	128	137	149	-	133	141	154	-	

75	MBh	25.2	25.9	28.1	30.1	24.6	25.3	27.4	29.4	24.0	24.7	26.8	28.7	23.4	24.1	26.1	28.0	22.3	22.9	24.8	26.6	20.6	21.2	23.0	24.7
	S/T	0.87	0.78	0.59	0.38	0.90	0.81	0.61	0.39	0.92	0.83	0.63	0.40	0.95	0.85	0.65	0.42	0.99	0.89	0.67	0.43	1.00	0.89	0.68	0.44
	ΔT	21	19	16	11	21	20	16	11	21	20	16	11	22	20	16	11	21	20	16	11	20	18	15	10
	kW	1.35	1.38	1.43	1.48	1.46	1.50	1.55	1.60	1.56	1.60	1.65	1.71	1.65	1.69	1.75	1.81	1.72	1.76	1.83	1.89	1.79	1.83	1.89	1.96
	Amps	5.4	5.5	5.7	5.9	5.8	5.9	6.1	6.4	6.3	6.5	6.7	6.9	6.7	6.9	7.1	7.4	7.2	7.3	7.6	7.9	7.6	7.8	8.0	8.4
	Hi PR	211	227	240	250	237	255	269	281	269	290	306	319	307	330	349	364	345	371	392	409	381	410	433	452
	Lo PR	112	119	130	138	118	126	137	146	123	131	143	152	129	137	150	159	135	144	157	167	140	149	162	173
	MBh	24.5	25.2	27.3	29.3	23.9	24.6	26.6	28.6	23.3	24.0	26.0	27.9	22.8	23.4	25.4	27.2	21.6	22.3	24.1	25.9	20.0	20.6	22.3	24.0
	S/T	0.83	0.74	0.56	0.36	0.86	0.77	0.58	0.37	0.88	0.79	0.60	0.38	0.91	0.81	0.62	0.40	0.94	0.85	0.64	0.41	0.95	0.85	0.64	0.41
	ΔT	22	20	17	11	22	20	17	12	22	20	17	12	22	21	17	12	22	20	17	12	21	19	16	11
kW	1.34	1.37	1.42	1.47	1.45	1.48	1.54	1.59	1.55	1.59	1.64	1.70	1.64	1.67	1.73	1.79	1.71	1.75	1.81	1.87	1.77	1.81	1.88	1.95	
Amps	5.3	5.4	5.6	5.8	5.7	5.9	6.1	6.3	6.2	6.4	6.6	6.9	6.7	6.8	7.1	7.3	7.1	7.3	7.5	7.8	7.5	7.7	8.0	8.3	
Hi PR	209	225	237	248	234	252	266	278	267	287	303	316	304	327	345	360	342	368	388	405	378	406	429	447	
Lo PR	111	118	128	137	117	124	136	145	121	129	141	150	128	136	148	158	134	142	155	165	138	147	161	171	
MBh	22.6	23.3	25.2	27.0	22.1	22.7	24.6	26.4	21.5	22.2	24.0	25.8	21.0	21.6	23.4	25.1	20.0	20.5	22.2	23.9	18.5	19.0	20.6	22.1	
S/T	0.80	0.72	0.54	0.35	0.83	0.74	0.56	0.36	0.85	0.76	0.58	0.37	0.88	0.79	0.59	0.38	0.91	0.81	0.62	0.40	0.92	0.82	0.62	0.40	
ΔT	22	21	17	12	23	21	17	12	23	21	17	12	23	21	17	12	23	21	17	12	21	19	16	11	
kW	1.31	1.34	1.38	1.43	1.41	1.45	1.50	1.55	1.51	1.54	1.60	1.65	1.59	1.63	1.69	1.75	1.66	1.70	1.76	1.82	1.72	1.77	1.83	1.89	
Amps	5.2	5.3	5.5	5.7	5.6	5.7	5.9	6.1	6.1	6.2	6.4	6.7	6.5	6.6	6.9	7.1	6.9	7.1	7.3	7.6	7.3	7.5	7.7	8.0	
Hi PR	203	218	230	240	227	245	258	270	259	278	294	307	295	317	335	349	331	357	377	393	366	394	416	434	
Lo PR	107	114	125	133	113	121	132	140	118	125	137	146	124	132	144	153	130	138	151	160	134	143	156	166	

Shaded area is ACCA (TVA) conditions IDB: Entering Indoor Dry Bulb Temperature kW = Total system power Amps = outdoor unit amps (comp.+fan)  
 High and low pressures are measured at the liquid and suction service valves. Design Subcooling 5 - 7 °F @ the liquid service valve, AHR1 95 test conditions

EXPANDED COOLING DATA — ASZC180361A\*/CA\*F3743\*6\*\*+TXV/MBVC1600\*\* LOW STAGE (CONT.)

IDB	AIRFLOW	OUTDOOR AMBIENT TEMPERATURE																							
		65°F				75°F				85°F				95°F				105°F				115°F			
		59	63	67	71	59	63	67	71	59	63	67	71	59	63	67	71	59	63	67	71	59	63	67	71
80	MBh	25.7	26.2	28.0	29.9	25.1	25.6	27.4	29.2	24.5	25.0	26.7	28.5	23.9	24.4	26.0	27.8	22.7	23.2	24.7	26.5	21.0	21.5	22.9	24.5
	S/T	0.95	0.90	0.73	0.54	1.00	0.93	0.75	0.56	1.00	0.95	0.77	0.58	1.00	1.00	0.80	0.60	1.00	1.00	0.83	0.62	1.00	1.00	0.84	0.63
	ΔT	24	23	20	16	24	23	20	16	23	23	20	16	23	23	20	16	22	22	20	16	20	20	18	15
	kW	1.36	1.39	1.44	1.49	1.48	1.51	1.56	1.62	1.58	1.61	1.67	1.73	1.66	1.70	1.76	1.83	1.74	1.78	1.84	1.91	1.80	1.85	1.91	1.98
	Amps	5.4	5.5	5.7	5.9	5.9	6.0	6.2	6.4	6.4	6.5	6.7	7.0	6.8	7.0	7.2	7.5	7.2	7.4	7.7	8.0	7.7	7.9	8.1	8.4
	Hi PR	213	229	242	253	239	257	272	284	272	293	309	322	310	333	352	367	349	375	396	413	385	415	438	457
	Lo PR	113	120	131	140	119	127	138	147	124	132	144	153	130	138	151	161	136	145	158	169	141	150	164	175
	MBh	24.9	25.4	27.2	29.1	24.3	24.9	26.6	28.4	23.7	24.3	25.9	27.7	23.2	23.7	25.3	27.0	22.0	22.5	24.0	25.7	20.4	20.8	22.3	23.8
	S/T	0.91	0.85	0.69	0.52	0.94	0.88	0.72	0.54	0.97	0.91	0.74	0.55	1.00	0.94	0.76	0.57	1.00	0.97	0.79	0.59	1.00	0.98	0.80	0.60
	ΔT	25	23	20	16	25	24	21	17	25	24	21	17	25	24	21	17	24	24	21	16	22	22	19	15
kW	1.35	1.38	1.43	1.48	1.46	1.50	1.55	1.60	1.56	1.60	1.65	1.71	1.65	1.69	1.75	1.81	1.72	1.76	1.83	1.89	1.79	1.83	1.89	1.96	
Amps	5.4	5.5	5.7	5.9	5.8	5.9	6.1	6.4	6.3	6.5	6.7	6.9	6.7	6.9	7.1	7.4	7.2	7.3	7.6	7.9	7.6	7.8	8.0	8.4	
Hi PR	211	227	240	250	237	255	269	281	269	290	306	319	307	330	349	364	345	371	392	409	381	410	433	452	
Lo PR	112	119	130	138	118	126	137	146	123	131	143	152	129	137	150	159	135	144	157	167	140	149	162	173	
MBh	23.0	23.5	25.1	26.8	22.5	22.9	24.5	26.2	21.9	22.4	23.9	25.6	21.4	21.8	23.3	25.0	20.3	20.8	22.2	23.7	18.8	19.2	20.5	22.0	
S/T	0.88	0.82	0.67	0.50	0.91	0.85	0.69	0.52	0.93	0.87	0.71	0.53	0.96	0.90	0.73	0.55	1.00	0.94	0.76	0.57	1.01	0.94	0.77	0.57	
ΔT	25	24	21	17	25	24	21	17	25	24	21	17	25	24	21	17	25	24	21	17	23	22	20	16	
kW	1.32	1.35	1.39	1.44	1.43	1.46	1.51	1.56	1.52	1.56	1.61	1.67	1.61	1.64	1.70	1.76	1.68	1.72	1.78	1.84	1.74	1.78	1.84	1.91	
Amps	5.2	5.3	5.5	5.7	5.6	5.8	6.0	6.2	6.1	6.3	6.5	6.7	6.5	6.7	6.9	7.2	7.0	7.1	7.4	7.7	7.4	7.6	7.8	8.1	
Hi PR	205	220	233	243	230	247	261	272	261	281	297	310	298	320	338	353	335	360	380	397	370	398	420	438	
Lo PR	108	115	126	134	115	122	133	142	119	127	138	147	125	133	145	155	131	139	152	162	136	144	157	168	

85	MBh	26.1	26.6	27.9	29.7	25.5	26.0	27.2	29.0	24.9	25.4	26.6	28.3	24.3	24.7	25.9	27.7	23.1	23.5	24.6	26.3	21.4	21.8	22.8	24.3
	S/T	1.00	0.97	0.87	0.71	1.00	1.00	0.90	0.73	1.00	1.00	0.93	0.75	1.00	1.00	0.96	0.78	1.00	1.00	0.99	0.80	1.00	1.00	1.00	0.81
	ΔT	25	25	23	20	25	25	24	20	24	24	24	20	23	24	24	21	22	23	23	20	21	21	21	19
	kW	1.38	1.41	1.45	1.50	1.49	1.52	1.58	1.63	1.59	1.63	1.68	1.74	1.68	1.72	1.78	1.84	1.75	1.80	1.86	1.93	1.82	1.86	1.93	2.00
	Amps	5.5	5.6	5.8	6.0	5.9	6.0	6.2	6.5	6.4	6.6	6.8	7.0	6.9	7.0	7.3	7.5	7.3	7.5	7.7	8.0	7.7	7.9	8.2	8.5
	Hi PR	215	232	245	255	242	260	275	286	275	296	312	326	313	337	356	371	352	379	400	417	389	419	442	461
	Lo PR	114	121	132	141	120	128	140	149	125	133	145	155	131	140	153	163	138	147	160	170	143	152	166	176
	MBh	25.3	25.8	27.1	28.9	24.7	25.2	26.4	28.2	24.2	24.6	25.8	27.5	23.6	24.0	25.2	26.8	22.4	22.8	23.9	25.5	20.7	21.1	22.1	23.6
	S/T	0.95	0.92	0.83	0.67	0.99	0.95	0.86	0.70	1.00	0.98	0.88	0.72	1.00	1.00	0.91	0.74	1.00	1.00	0.95	0.77	1.00	1.00	0.95	0.77
	ΔT	26	26	24	21	26	26	25	21	26	26	25	21	25	26	25	21	25	25	24	21	22	22	23	20
kW	1.36	1.39	1.44	1.49	1.48	1.51	1.56	1.62	1.58	1.61	1.67	1.73	1.66	1.70	1.76	1.83	1.74	1.78	1.84	1.91	1.80	1.85	1.91	1.98	
Amps	5.4	5.5	5.7	5.9	5.9	6.0	6.2	6.4	6.4	6.5	6.7	7.0	6.8	7.0	7.2	7.5	7.2	7.4	7.7	8.0	7.7	7.9	8.1	8.4	
Hi PR	213	229	242	253	239	257	272	284	272	293	309	322	310	333	352	367	349	375	396	413	385	415	438	457	
Lo PR	113	120	131	140	119	127	138	147	124	132	144	153	130	138	151	161	136	145	158	169	141	150	164	175	
MBh	23.4	23.8	25.0	26.6	22.8	23.3	24.4	26.0	22.3	22.7	23.8	25.4	21.8	22.2	23.2	24.8	20.7	21.1	22.1	23.5	19.1	19.5	20.4	21.8	
S/T	0.92	0.89	0.80	0.65	0.95	0.92	0.83	0.67	0.98	0.94	0.85	0.69	1.00	0.97	0.88	0.71	1.00	1.00	0.91	0.74	1.00	1.00	0.92	0.75	
ΔT	26.6	26	25	21	27	26	25	22	27	27	25	22	27	27	25	22	26	26	25	22	24	24	23	20	
kW	1.33	1.36	1.40	1.45	1.44	1.47	1.52	1.57	1.53	1.57	1.62	1.68	1.62	1.66	1.72	1.78	1.69	1.73	1.79	1.86	1.76	1.80	1.86	1.93	
Amps	5.3	5.4	5.6	5.8	5.7	5.8	6.0	6.2	6.2	6.3	6.5	6.8	6.6	6.8	7.0	7.3	7.0	7.2	7.4	7.7	7.5	7.6	7.9	8.2	
Hi PR	207	223	235	245	232	250	264	275	264	284	300	313	301	323	342	356	338	364	384	401	374	402	425	443	
Lo PR	109	116	127	135	116	123	134	143	120	128	140	149	126	134	147	156	132	141	154	164	137	146	159	169	

Shaded area is AHRI Rating conditions IDB: Entering Indoor Dry Bulb Temperature  
 High and low pressures are measured at the liquid and suction service valves.  
 kW = Total system power  
 Amps = outdoor unit amps (comp.+fan)  
 Design Subcooling 5 - 7 °F @ the liquid service valve, AHRI 95 test conditions

EXPANDED COOLING DATA — ASZC180361A\*/CA\*F3743\*6\*\*+TXV/MBVC1600\*\* HIGH STAGE

IDB	AIRFLOW	OUTDOOR AMBIENT TEMPERATURE																							
		65°F				75°F				85°F				95°F				105°F				115°F			
		59	63	67	71	59	63	67	71	59	63	67	71	59	63	67	71	59	63	67	71	59	63	67	71
70	MBh	34.5	35.8	39.2	-	33.7	34.9	38.3	-	32.9	34.1	37.4	-	32.1	33.3	36.5	-	30.5	31.6	34.6	-	28.3	29.3	32.1	-
	S/T	0.76	0.63	0.44	-	0.79	0.66	0.45	-	0.81	0.67	0.47	-	0.83	0.70	0.48	-	0.86	0.72	0.50	-	0.87	0.73	0.50	-
	ΔT	17	15	11	-	17	15	11	-	17	15	11	-	17	15	11	-	17	15	11	-	16	14	11	-
	kW	2.10	2.14	2.21	-	2.26	2.31	2.39	-	2.41	2.47	2.55	-	2.54	2.60	2.69	-	2.65	2.71	2.81	-	2.75	2.81	2.91	-
	Amps	7.8	8.0	8.2	-	8.4	8.6	8.9	-	9.2	9.4	9.7	-	9.8	10.1	10.4	-	10.5	10.7	11.1	-	11.1	11.4	11.8	-
	Hi PR	219	235	249	-	245	264	279	-	279	300	317	-	318	342	361	-	358	385	406	-	395	425	449	-
	Lo PR	107	114	124	-	113	120	131	-	117	125	136	-	123	131	143	-	129	137	150	-	134	142	155	-
	MBh	33.5	34.7	38.1	-	32.7	33.9	37.2	-	32.0	33.1	36.3	-	31.2	32.3	35.4	-	29.6	30.7	33.6	-	27.4	28.4	31.2	-
	S/T	0.72	0.60	0.42	-	0.75	0.63	0.43	-	0.77	0.64	0.44	-	0.79	0.66	0.46	-	0.82	0.69	0.48	-	0.83	0.69	0.48	-
	ΔT	18	15	12	-	18	16	12	-	18	16	12	-	18	16	12	-	18	16	12	-	17	15	11	-
kW	2.08	2.13	2.19	-	2.25	2.30	2.37	-	2.39	2.45	2.53	-	2.52	2.58	2.67	-	2.63	2.69	2.78	-	2.73	2.79	2.88	-	
Amps	7.7	7.9	8.1	-	8.3	8.5	8.8	-	9.1	9.3	9.6	-	9.7	10.0	10.3	-	10.4	10.6	11.0	-	11.0	11.3	11.7	-	
Hi PR	217	233	246	-	243	261	276	-	276	297	314	-	315	339	358	-	354	381	402	-	391	421	445	-	
Lo PR	106	113	123	-	112	119	130	-	116	124	135	-	122	130	142	-	128	136	149	-	132	141	154	-	
MBh	30.9	32.1	35.1	-	30.2	31.3	34.3	-	29.5	30.6	33.5	-	28.8	29.8	32.7	-	27.3	28.3	31.0	-	25.3	26.2	28.8	-	
S/T	0.70	0.58	0.40	-	0.72	0.60	0.42	-	0.74	0.62	0.43	-	0.77	0.64	0.44	-	0.79	0.66	0.46	-	0.80	0.67	0.46	-	
ΔT	18	16	12	-	18	16	12	-	18	16	12	-	19	16	12	-	18	16	12	-	17	15	11	-	
kW	2.03	2.07	2.14	-	2.19	2.24	2.31	-	2.33	2.38	2.46	-	2.46	2.51	2.60	-	2.56	2.62	2.71	-	2.66	2.72	2.81	-	
Amps	7.5	7.7	7.9	-	8.1	8.3	8.6	-	8.8	9.0	9.3	-	9.4	9.7	10.0	-	10.1	10.3	10.7	-	10.7	10.9	11.3	-	
Hi PR	210	226	239	-	236	254	268	-	268	288	305	-	305	329	347	-	343	370	390	-	379	408	431	-	
Lo PR	103	109	119	-	108	115	126	-	113	120	131	-	118	126	138	-	124	132	144	-	128	137	149	-	

75	MBh	35.1	36.1	39.1	42.0	34.3	35.3	38.2	41.0	33.5	34.5	37.3	40.0	32.7	33.6	36.4	39.1	31.0	31.9	34.6	37.1	28.7	29.6	32.0	34.4
	S/T	0.86	0.77	0.58	0.38	0.89	0.80	0.60	0.39	0.92	0.82	0.62	0.40	0.95	0.85	0.64	0.41	0.98	0.88	0.66	0.43	0.99	0.89	0.67	0.43
	ΔT	20	18	15	10	20	18	15	10	20	18	15	10	20	19	15	11	20	18	15	10	19	17	14	10
	kW	2.11	2.16	2.23	2.31	2.28	2.33	2.41	2.49	2.43	2.49	2.57	2.66	2.56	2.62	2.71	2.81	2.68	2.74	2.83	2.93	2.77	2.84	2.94	3.04
	Amps	7.8	8.0	8.3	8.6	8.5	8.7	9.0	9.3	9.2	9.5	9.8	10.2	9.9	10.2	10.5	10.9	10.6	10.8	11.2	11.6	11.2	11.5	11.9	12.3
	Hi PR	221	238	251	262	248	267	282	294	282	303	320	334	321	346	365	381	361	389	411	428	399	430	454	473
	Lo PR	108	115	125	134	114	121	133	141	119	126	138	147	125	133	145	154	131	139	152	161	135	144	157	167
	MBh	34.1	35.1	38.0	40.8	33.3	34.3	37.1	39.8	32.5	33.5	36.2	38.9	31.7	32.6	35.3	37.9	30.1	31.0	33.6	36.0	27.9	28.7	31.1	33.4
	S/T	0.82	0.74	0.56	0.36	0.85	0.76	0.58	0.37	0.87	0.78	0.59	0.38	0.90	0.81	0.61	0.39	0.94	0.84	0.63	0.41	0.94	0.84	0.64	0.41
	ΔT	21	19	16	11	21	19	16	11	21	19	16	11	21	19	16	11	21	19	16	11	19	18	15	10
kW	2.10	2.14	2.21	2.29	2.26	2.32	2.39	2.47	2.41	2.47	2.55	2.64	2.54	2.60	2.69	2.78	2.65	2.72	2.81	2.91	2.75	2.81	2.91	3.01	
Amps	7.8	8.0	8.2	8.5	8.4	8.6	8.9	9.3	9.2	9.4	9.7	10.1	9.8	10.1	10.4	10.8	10.5	10.7	11.1	11.5	11.1	11.4	11.8	12.2	
Hi PR	219	235	249	259	245	264	279	291	279	300	317	331	318	342	361	377	358	385	406	424	395	425	449	468	
Lo PR	107	114	124	132	113	120	131	140	117	125	136	145	123	131	143	153	129	138	150	160	134	142	155	165	
MBh	31.5	32.4	35.1	37.6	30.7	31.6	34.2	36.8	30.0	30.9	33.4	35.9	29.3	30.1	32.6	35.0	27.8	28.6	31.0	33.3	25.8	26.5	28.7	30.8	
S/T	0.79	0.71	0.54	0.35	0.82	0.74	0.56	0.36	0.84	0.75	0.57	0.37	0.87	0.78	0.59	0.38	0.90	0.81	0.61	0.39	0.91	0.81	0.62	0.40	
ΔT	21	19	16	11	21	20	16	11	21	20	16	11	21	20	16	11	21	19	16	11	20	18	15	10	
kW	2.04	2.09	2.16	2.23	2.21	2.26	2.33	2.41	2.35	2.40	2.48	2.57	2.48	2.53	2.62	2.71	2.59	2.64	2.73	2.83	2.68	2.74	2.83	2.93	
Amps	7.5	7.7	8.0	8.3	8.2	8.4	8.7	9.0	8.9	9.1	9.4	9.8	9.5	9.8	10.1	10.5	10.2	10.4	10.8	11.2	10.8	11.1	11.4	11.9	
Hi PR	212	228	241	251	238	256	271	282	271	291	308	321	308	332	350	366	347	373	394	411	383	413	436	454	
Lo PR	104	110	120	128	110	117	127	136	114	121	132	141	120	127	139	148	125	133	146	155	130	138	151	160	

Shaded area is ACCA (TVA) conditions IDB: Entering Indoor Dry Bulb Temperature kW = Total system power Amps = outdoor unit amps (comp.+fan)  
 High and low pressures are measured at the liquid and suction service valves. Design Subcooling 5 - 7 °F @ the liquid service valve, AHR1 95 test conditions



EXPANDED COOLING DATA — ASZC180361A\*/CA\*F3743\*6\*\*+TXV/MBVC1600\*\* HIGH STAGE (CONT.)

IDB	AIRFLOW	OUTDOOR AMBIENT TEMPERATURE																							
		65°F				75°F				85°F				95°F				105°F				115°F			
		59	63	67	71	59	63	67	71	59	63	67	71	59	63	67	71	59	63	67	71	59	63	67	71
1406	MBh	35.7	36.5	39.0	41.7	34.9	35.7	38.1	40.7	34.1	34.8	37.2	39.8	33.2	34.0	36.3	38.8	31.6	32.3	34.5	36.8	29.2	29.9	31.9	34.1
	S/T	0.95	0.89	0.72	0.54	1.00	0.92	0.75	0.56	1.00	0.94	0.77	0.57	1.00	1.00	0.79	0.59	1.00	1.00	0.82	0.61	1.00	1.00	0.83	0.62
	ΔT	22	21	18	15	23	22	19	15	22	22	19	15	22	22	19	15	21	21	19	15	19	20	17	14
	kW	2.13	2.18	2.25	2.33	2.30	2.35	2.43	2.52	2.45	2.51	2.59	2.68	2.59	2.65	2.74	2.83	2.70	2.76	2.86	2.96	2.80	2.86	2.96	3.07
	Amps	7.9	8.1	8.4	8.7	8.6	8.8	9.1	9.4	9.3	9.6	9.9	10.3	10.0	10.2	10.6	11.0	10.7	10.9	11.3	11.7	11.3	11.6	12.0	12.5
	Hi PR	223	240	254	265	250	269	285	297	285	306	324	338	324	349	369	384	365	393	415	433	403	434	458	478
	Lo PR	109	116	127	135	115	123	134	143	120	127	139	148	126	134	146	156	132	140	153	163	136	145	158	169
	MBh	34.7	35.4	37.9	40.5	33.9	34.6	37.0	39.5	33.1	33.8	36.1	38.6	32.3	33.0	35.2	37.7	30.7	31.3	33.5	35.8	28.4	29.0	31.0	33.1
	S/T	0.90	0.85	0.69	0.51	0.93	0.88	0.71	0.53	0.96	0.90	0.73	0.55	0.99	0.93	0.76	0.56	1.00	0.96	0.78	0.59	1.00	0.97	0.79	0.59
	ΔT	23	22	19	15	23	22	19	16	23	22	19	16	23	23	20	16	23	22	19	15	21	21	18	14
80	kW	2.11	2.16	2.23	2.31	2.28	2.33	2.41	2.49	2.43	2.49	2.57	2.66	2.57	2.62	2.71	2.81	2.68	2.74	2.83	2.93	2.77	2.84	2.94	3.04
	Amps	7.8	8.0	8.3	8.6	8.5	8.7	9.0	9.3	9.2	9.5	9.8	10.2	9.9	10.2	10.5	10.9	10.6	10.8	11.2	11.6	11.2	11.5	11.9	12.3
	Hi PR	221	238	251	262	248	267	282	294	282	303	320	334	321	346	365	381	361	389	411	428	399	430	454	473
	Lo PR	108	115	125	134	114	121	133	141	119	126	138	147	125	133	145	154	131	139	152	162	135	144	157	167
	MBh	32.0	32.7	35.0	37.4	31.3	32.0	34.1	36.5	30.5	31.2	33.3	35.6	29.8	30.4	32.5	34.8	28.3	28.9	30.9	33.0	26.2	26.8	28.6	30.6
	S/T	0.87	0.82	0.66	0.50	0.90	0.85	0.69	0.51	0.92	0.87	0.71	0.53	0.95	0.89	0.73	0.54	0.99	0.93	0.76	0.56	1.00	0.94	0.76	0.57
	ΔT	23	22	20	16	24	23	20	16	24	23	20	16	24	23	20	16	24	23	20	16	22	21	18	15
	kW	2.06	2.11	2.18	2.25	2.23	2.28	2.35	2.43	2.37	2.42	2.51	2.59	2.50	2.56	2.64	2.73	2.61	2.67	2.76	2.85	2.70	2.76	2.86	2.96
	Amps	7.6	7.8	8.1	8.4	8.3	8.5	8.7	9.1	9.0	9.2	9.5	9.9	9.6	9.9	10.2	10.6	10.3	10.5	10.9	11.3	10.9	11.2	11.5	12.0
	Hi PR	214	231	244	254	240	259	273	285	274	294	311	324	312	335	354	369	350	377	398	415	387	417	440	459
Lo PR	105	111	122	130	111	118	129	137	115	122	134	142	121	129	140	149	127	135	147	157	131	139	152	162	

1406	MBh	36.4	37.1	38.8	41.4	35.5	36.2	37.9	40.4	34.7	35.3	37.0	39.5	33.8	34.5	36.1	38.5	32.1	32.7	34.3	36.6	29.8	30.3	31.8	33.9
	S/T	0.99	0.96	0.86	0.70	1.00	0.99	0.89	0.73	1.00	1.00	0.92	0.74	1.00	1.00	0.95	0.77	1.00	1.00	0.98	0.80	1.00	1.00	0.99	0.80
	ΔT	24	23	22	19	23	23	22	19	23	23	22	19	22	23	22	19	21	21	22	19	19	20	21	18
	kW	2.15	2.20	2.27	2.35	2.32	2.37	2.45	2.54	2.47	2.53	2.62	2.71	2.61	2.67	2.76	2.86	2.72	2.79	2.88	2.98	2.82	2.89	2.99	3.09
	Amps	8.0	8.2	8.5	8.8	8.7	8.9	9.2	9.5	9.4	9.7	10.0	10.4	10.1	10.3	10.7	11.1	10.8	11.0	11.4	11.9	11.4	11.7	12.1	12.6
	Hi PR	225	243	256	267	253	272	287	300	288	310	327	341	328	353	372	388	369	397	419	437	407	438	463	483
	Lo PR	110	117	128	136	116	124	135	144	121	129	141	150	127	135	148	157	133	142	155	165	138	147	160	170
	MBh	35.3	36.0	37.7	40.2	34.5	35.1	36.8	39.3	33.7	34.3	35.9	38.3	32.8	33.5	35.1	37.4	31.2	31.8	33.3	35.5	28.9	29.5	30.8	32.9
	S/T	0.95	0.91	0.82	0.67	0.98	0.95	0.85	0.69	1.00	0.97	0.88	0.71	1.00	1.00	0.90	0.73	1.00	1.00	0.94	0.76	1.00	1.00	0.95	0.77
	ΔT	25	24	23	20	25	24	23	20	25	24	23	20	24	25	23	20	24	25	23	20	21	22	21	19
85	kW	2.13	2.18	2.25	2.33	2.30	2.35	2.43	2.52	2.45	2.51	2.59	2.68	2.59	2.65	2.74	2.83	2.70	2.76	2.86	2.96	2.80	2.86	2.96	3.07
	Amps	7.9	8.1	8.4	8.7	8.6	8.8	9.1	9.4	9.3	9.6	9.9	10.3	10.0	10.2	10.6	11.0	10.7	10.9	11.3	11.7	11.3	11.6	12.0	12.5
	Hi PR	223	240	254	265	250	269	285	297	285	306	324	338	324	349	369	384	365	393	415	433	403	434	458	478
	Lo PR	109	116	127	135	115	123	134	143	120	127	139	148	126	134	146	156	132	140	153	163	136	145	158	169
	MBh	32.6	33.2	34.8	37.1	31.8	32.4	34.0	36.2	31.1	31.7	33.2	35.4	30.3	30.9	32.4	34.5	28.8	29.3	30.7	32.8	26.7	27.2	28.5	30.4
	S/T	0.91	0.88	0.79	0.64	0.94	0.91	0.82	0.67	0.97	0.93	0.84	0.68	1.00	0.97	0.87	0.71	1.00	1.00	0.90	0.73	1.00	1.00	0.91	0.74
	ΔT	25	25	23	20	25	25	23	20	25	25	24	20	25	25	24	21	24	25	23	20	22	23	22	19
	kW	2.08	2.12	2.19	2.27	2.24	2.29	2.37	2.45	2.39	2.45	2.53	2.61	2.52	2.58	2.67	2.76	2.63	2.69	2.78	2.88	2.73	2.79	2.88	2.98
	Amps	7.7	7.9	8.1	8.5	8.3	8.5	8.8	9.2	9.1	9.3	9.6	10.0	9.7	10.0	10.3	10.7	10.4	10.6	11.0	11.4	11.0	11.3	11.7	12.1
	Hi PR	216	233	246	257	243	261	276	288	276	297	314	327	315	339	358	373	354	381	402	420	391	421	444	464
Lo PR	106	113	123	131	112	119	130	138	116	124	135	144	122	130	142	151	128	136	149	158	132	141	154	164	

Shaded area is AHR1 Rating conditions IDB: Entering Indoor Dry Bulb Temperature kW = Total system power Amps = outdoor unit amps (comp.+fan)  
 High and low pressures are measured at the liquid and suction service valves. Design Subcooling 5 - 7 °F @ the liquid service valve, AHR1 95 test conditions

EXPANDED COOLING DATA — ASZC180481A\*/CA\*F3743\*6\*\*+TXV/MBVC2000\*\* Low STAGE

IDB	AIRFLOW	OUTDOOR AMBIENT TEMPERATURE																							
		65°F				75°F				85°F				95°F				105°F				115°F			
		59	63	67	71	59	63	67	71	59	63	67	71	59	63	67	71	59	63	67	71	59	63	67	71
70	MBh	35.0	36.3	39.8	-	34.2	35.5	38.9	-	33.4	34.6	37.9	-	32.6	33.8	37.0	-	31.0	32.1	35.2	-	28.7	29.7	32.6	-
	S/T	0.76	0.63	0.44	-	0.78	0.65	0.45	-	0.80	0.67	0.46	-	0.83	0.69	0.48	-	0.86	0.72	0.50	-	0.87	0.72	0.50	-
	ΔT	18	16	12	-	18	16	12	-	18	16	12	-	18	16	12	-	18	16	12	-	17	15	11	-
	kW	1.85	1.89	1.96	-	2.01	2.05	2.13	-	2.14	2.20	2.27	-	2.27	2.32	2.40	-	2.37	2.43	2.51	-	2.46	2.52	2.61	-
	Amps	0.1	0.1	0.1	-	0.1	0.1	0.1	-	0.1	0.1	0.1	-	0.1	0.1	0.1	-	0.1	0.1	0.1	-	0.1	0.1	0.1	-
	Hi PR	209	225	237	-	234	252	266	-	266	287	303	-	303	326	345	-	341	367	388	-	377	406	429	-
	Lo PR	110	117	128	-	116	123	135	-	121	128	140	-	127	135	147	-	133	141	154	-	137	146	160	-
	MBh	34.0	35.3	38.6	-	33.2	34.4	37.7	-	32.4	33.6	36.8	-	31.6	32.8	35.9	-	30.1	31.2	34.1	-	27.8	28.9	31.6	-
	S/T	0.72	0.60	0.42	-	0.75	0.62	0.43	-	0.77	0.64	0.44	-	0.79	0.66	0.46	-	0.82	0.69	0.47	-	0.83	0.69	0.48	-
	ΔT	19	16	12	-	19	16	12	-	19	16	13	-	19	17	13	-	19	16	12	-	18	15	12	-
1050	kW	1.84	1.88	1.94	-	1.99	2.04	2.11	-	2.13	2.18	2.25	-	2.25	2.30	2.38	-	2.35	2.40	2.49	-	2.44	2.49	2.58	-
	Amps	0.1	0.1	0.1	-	0.1	0.1	0.1	-	0.1	0.1	0.1	-	0.1	0.1	0.1	-	0.1	0.1	0.1	-	0.1	0.1	0.1	-
	Hi PR	207	222	235	-	232	250	264	-	264	284	300	-	300	323	341	-	338	364	384	-	373	402	424	-
	Lo PR	109	116	126	-	115	122	133	-	119	127	139	-	125	133	146	-	131	140	153	-	136	145	158	-
	MBh	31.4	32.5	35.7	-	30.7	31.8	34.8	-	29.9	31.0	34.0	-	29.2	30.3	33.2	-	27.7	28.8	31.5	-	25.7	26.6	29.2	-
	S/T	0.70	0.58	0.40	-	0.72	0.60	0.42	-	0.74	0.62	0.43	-	0.76	0.64	0.44	-	0.79	0.66	0.46	-	0.80	0.67	0.46	-
	ΔT	19	17	13	-	19	17	13	-	19	17	13	-	19	17	13	-	19	17	13	-	18	16	12	-
	kW	1.79	1.83	1.89	-	1.94	1.98	2.05	-	2.07	2.12	2.19	-	2.19	2.24	2.32	-	2.28	2.34	2.42	-	2.37	2.43	2.51	-
	Amps	0.1	0.1	0.1	-	0.1	0.1	0.1	-	0.1	0.1	0.1	-	0.1	0.1	0.1	-	0.1	0.1	0.1	-	0.1	0.1	0.1	-
	Hi PR	200	216	228	-	225	242	256	-	256	275	291	-	291	314	331	-	328	353	372	-	362	390	412	-
Lo PR	106	112	123	-	111	119	129	-	116	123	135	-	122	129	141	-	128	136	148	-	132	140	153	-	

75	MBh	35.6	36.7	39.7	42.6	34.8	35.8	38.8	41.6	34.0	35.0	37.9	40.6	33.1	34.1	36.9	39.6	31.5	32.4	35.1	37.7	29.2	30.0	32.5	34.9
	S/T	0.86	0.77	0.58	0.37	0.89	0.80	0.60	0.39	0.91	0.82	0.62	0.40	0.94	0.84	0.64	0.41	0.98	0.87	0.66	0.43	0.99	0.88	0.67	0.43
	ΔT	21	19	16	11	21	19	16	11	21	19	16	11	21	20	16	11	21	19	16	11	20	18	15	10
	kW	1.87	1.91	1.98	2.05	2.03	2.07	2.14	2.22	2.16	2.22	2.29	2.37	2.29	2.34	2.42	2.51	2.39	2.45	2.53	2.63	2.48	2.54	2.63	2.73
	Amps	0.1	0.1	0.1	0.1	0.1	0.1	0.1	0.1	0.1	0.1	0.1	0.1	0.1	0.1	0.1	0.1	0.1	0.1	0.1	0.1	0.1	0.1	0.1	0.1
	Hi PR	211	227	240	250	237	255	269	280	269	290	306	319	306	330	348	363	345	371	392	409	381	410	433	452
	Lo PR	111	118	129	137	117	125	136	145	122	130	142	151	128	136	149	158	134	143	156	166	139	148	161	172
	MBh	34.6	35.6	38.5	41.4	33.8	34.8	37.7	40.4	33.0	34.0	36.8	39.4	32.2	33.1	35.9	38.5	30.6	31.5	34.1	36.6	28.3	29.2	31.6	33.9
	S/T	0.82	0.73	0.55	0.36	0.85	0.76	0.57	0.37	0.87	0.78	0.59	0.38	0.90	0.80	0.61	0.39	0.93	0.83	0.63	0.41	0.94	0.84	0.64	0.41
	ΔT	22	20	16	11	22	20	17	11	22	20	17	11	22	20	17	12	22	20	16	11	20	19	15	11
1050	kW	1.85	1.89	1.96	2.03	2.01	2.05	2.13	2.20	2.15	2.20	2.27	2.35	2.27	2.32	2.40	2.49	2.37	2.43	2.51	2.60	2.46	2.52	2.61	2.70
	Amps	0.1	0.1	0.1	0.1	0.1	0.1	0.1	0.1	0.1	0.1	0.1	0.1	0.1	0.1	0.1	0.1	0.1	0.1	0.1	0.1	0.1	0.1	0.1	0.1
	Hi PR	209	225	237	247	234	252	266	278	266	287	303	316	303	327	345	360	341	367	388	405	377	406	429	447
	Lo PR	110	117	128	136	116	124	135	144	121	128	140	149	127	135	147	157	133	141	154	164	137	146	160	170
	MBh	31.9	32.9	35.6	38.2	31.2	32.1	34.8	37.3	30.4	31.3	33.9	36.4	29.7	30.6	33.1	35.5	28.2	29.0	31.4	33.7	26.1	26.9	29.1	31.3
	S/T	0.79	0.71	0.53	0.34	0.82	0.73	0.55	0.36	0.84	0.75	0.57	0.37	0.87	0.78	0.59	0.38	0.90	0.80	0.61	0.39	0.91	0.81	0.61	0.40
	ΔT	22	20	17	12	22	21	17	12	22	21	17	12	23	21	17	12	23	20	17	12	21	19	16	11
	kW	1.80	1.85	1.91	1.98	1.95	2.00	2.07	2.14	2.09	2.14	2.21	2.29	2.21	2.26	2.34	2.42	2.31	2.36	2.44	2.53	2.39	2.45	2.54	2.63
	Amps	0.1	0.1	0.1	0.1	0.1	0.1	0.1	0.1	0.1	0.1	0.1	0.1	0.1	0.1	0.1	0.1	0.1	0.1	0.1	0.1	0.1	0.1	0.1	0.1
	Hi PR	203	218	230	240	227	245	258	269	258	278	294	306	294	317	334	349	331	356	376	392	366	394	416	434
Lo PR	107	113	124	132	113	120	131	139	117	125	136	145	123	131	143	152	129	137	150	159	133	142	155	165	

Shaded area is ACCA (TVA) conditions IDB: Entering Indoor Dry Bulb Temperature kW = Total system power Amps = outdoor unit amps (comp.+fan)  
 High and low pressures are measured at the liquid and suction service valves. Design Subcooling 5 - 7 °F @ the liquid service valve, AHR1 95 test conditions



EXPANDED COOLING DATA — ASZC180481A\*/CA\*F3743\*6\*\*+TXV/MBVC2000\*\* Low STAGE (CONT.)

IDB	AIRFLOW	OUTDOOR AMBIENT TEMPERATURE																							
		65°F				75°F				85°F				95°F				105°F				115°F			
		59	63	67	71	59	63	67	71	59	63	67	71	59	63	67	71	59	63	67	71	59	63	67	71
80	MBh	36.3	37.1	39.6	42.3	35.4	36.2	38.7	41.3	34.6	35.3	37.7	40.3	33.7	34.5	36.8	39.4	32.0	32.7	35.0	37.4	29.7	30.3	32.4	34.6
	S/T	0.94	0.88	0.72	0.54	1.00	0.92	0.75	0.56	1.00	0.94	0.76	0.57	1.00	0.97	0.79	0.59	1.00	1.00	0.82	0.61	1.00	1.00	0.83	0.62
	ΔT	23	22	19	15	24	23	20	16	24	23	20	16	23	23	20	16	22	22	20	16	20	21	18	15
	kW	1.88	1.93	1.99	2.06	2.04	2.09	2.16	2.24	2.18	2.24	2.31	2.40	2.31	2.36	2.45	2.53	2.41	2.47	2.56	2.65	2.50	2.56	2.65	2.75
	Amps	0.1	0.1	0.1	0.1	0.1	0.1	0.1	0.1	0.1	0.1	0.1	0.1	0.1	0.1	0.1	0.1	0.1	0.1	0.1	0.1	0.1	0.1	0.1	0.1
	Hi PR	213	229	242	252	239	257	272	283	272	292	309	322	310	333	352	367	348	375	396	413	385	414	437	456
	Lo PR	112	119	130	139	118	126	138	147	123	131	143	152	129	138	150	160	136	144	157	168	140	149	163	173
	MBh	35.2	36.0	38.4	41.1	34.4	35.1	37.5	40.1	33.6	34.3	36.6	39.2	32.7	33.5	35.8	38.2	31.1	31.8	34.0	36.3	28.8	29.4	31.5	33.6
	S/T	0.90	0.84	0.69	0.51	0.93	0.87	0.71	0.53	0.96	0.90	0.73	0.54	0.99	0.92	0.75	0.56	1.00	0.96	0.78	0.58	1.00	0.97	0.79	0.59
	ΔT	24	23	20	16	25	24	20	16	25	24	20	16	25	24	21	16	24	23	20	16	22	22	19	15
kW	1.87	1.91	1.98	2.05	2.03	2.07	2.15	2.22	2.16	2.22	2.29	2.38	2.29	2.34	2.42	2.51	2.39	2.45	2.54	2.63	2.48	2.54	2.63	2.73	
Amps	0.1	0.1	0.1	0.1	0.1	0.1	0.1	0.1	0.1	0.1	0.1	0.1	0.1	0.1	0.1	0.1	0.1	0.1	0.1	0.1	0.1	0.1	0.1	0.1	
Hi PR	211	227	240	250	237	255	269	280	269	290	306	319	307	330	348	363	345	371	392	409	381	410	433	452	
Lo PR	111	118	129	137	117	125	136	145	122	130	142	151	128	136	149	158	134	143	156	166	139	148	161	172	
MBh	32.5	33.2	35.5	37.9	31.7	32.4	34.6	37.0	31.0	31.7	33.8	36.2	30.2	30.9	33.0	35.3	28.7	29.3	31.3	33.5	26.6	27.2	29.0	31.0	
S/T	0.87	0.81	0.66	0.49	0.90	0.84	0.69	0.51	0.92	0.86	0.70	0.53	0.95	0.89	0.73	0.54	0.99	0.93	0.75	0.56	0.99	0.93	0.76	0.57	
ΔT	25	24	21	16	25	24	21	17	25	24	21	17	25	24	21	17	25	24	21	17	23	22	19	15	
kW	1.82	1.86	1.93	1.99	1.97	2.02	2.09	2.16	2.11	2.16	2.23	2.31	2.23	2.28	2.36	2.44	2.33	2.38	2.47	2.56	2.41	2.47	2.56	2.65	
Amps	0.1	0.1	0.1	0.1	0.1	0.1	0.1	0.1	0.1	0.1	0.1	0.1	0.1	0.1	0.1	0.1	0.1	0.1	0.1	0.1	0.1	0.1	0.1	0.1	
Hi PR	205	220	232	242	230	247	261	272	261	281	297	309	297	320	338	352	334	360	380	396	370	398	420	438	
Lo PR	108	115	125	133	114	121	132	141	118	126	137	146	124	132	144	154	130	138	151	161	135	143	156	167	

85	MBh	36.9	37.6	39.4	42.0	36.0	36.7	38.5	41.0	35.2	35.9	37.6	40.1	34.3	35.0	36.6	39.1	32.6	33.2	34.8	37.1	30.2	30.8	32.2	34.4
	S/T	0.99	0.95	0.86	0.70	1.00	0.99	0.89	0.72	1.00	1.00	0.91	0.74	1.00	1.00	0.94	0.77	1.00	1.00	0.98	0.79	1.00	1.00	0.99	0.80
	ΔT	25	24	23	20	25	25	23	20	24	24	23	20	23	24	24	20	22	23	23	20	21	21	22	19
	kW	1.90	1.94	2.01	2.08	2.06	2.11	2.18	2.26	2.20	2.26	2.33	2.42	2.33	2.38	2.47	2.56	2.43	2.49	2.58	2.67	2.53	2.59	2.68	2.78
	Amps	0.1	0.1	0.1	0.1	0.1	0.1	0.1	0.1	0.1	0.1	0.1	0.1	0.1	0.1	0.1	0.1	0.1	0.1	0.1	0.1	0.1	0.1	0.1	0.1
	Hi PR	215	231	244	255	241	260	274	286	275	295	312	325	313	336	355	371	352	379	400	417	389	418	442	461
	Lo PR	113	120	132	140	120	127	139	148	124	132	144	154	131	139	152	162	137	146	159	169	142	151	164	175
	MBh	35.8	36.5	38.2	40.8	35.0	35.7	37.4	39.8	34.2	34.8	36.5	38.9	33.3	34.0	35.6	38.0	31.7	32.3	33.8	36.1	29.3	29.9	31.3	33.4
	S/T	0.94	0.91	0.82	0.67	0.98	0.94	0.85	0.69	1.00	0.97	0.87	0.71	1.00	1.00	0.90	0.73	1.00	1.00	0.93	0.76	1.00	1.00	0.94	0.76
	ΔT	26	25	24	21	26	26	24	21	26	26	24	21	26	26	25	21	24	25	24	21	22	23	23	20
kW	1.88	1.93	1.99	2.06	2.04	2.09	2.16	2.24	2.18	2.24	2.31	2.40	2.31	2.36	2.45	2.53	2.41	2.47	2.56	2.65	2.50	2.56	2.65	2.75	
Amps	0.1	0.1	0.1	0.1	0.1	0.1	0.1	0.1	0.1	0.1	0.1	0.1	0.1	0.1	0.1	0.1	0.1	0.1	0.1	0.1	0.1	0.1	0.1	0.1	
Hi PR	213	229	242	252	239	257	272	283	272	292	309	322	310	333	352	367	348	375	396	413	385	414	437	456	
Lo PR	112	119	130	139	118	126	138	147	123	131	143	152	129	138	150	160	136	144	157	168	140	149	163	173	
MBh	33.1	33.7	35.3	37.7	32.3	32.9	34.5	36.8	31.5	32.1	33.7	35.9	30.8	31.4	32.8	35.0	29.2	29.8	31.2	33.3	27.1	27.6	28.9	30.8	
S/T	0.91	0.88	0.79	0.64	0.94	0.91	0.82	0.67	0.97	0.93	0.84	0.68	1.00	0.96	0.87	0.70	1.00	1.00	0.90	0.73	1.00	1.00	0.91	0.74	
ΔT	26.3	26	24	21	27	26	25	21	27	26	25	21	27	26	25	22	26	26	25	21	24	24	23	20	
kW	1.84	1.88	1.94	2.01	1.99	2.04	2.11	2.18	2.13	2.18	2.25	2.33	2.25	2.30	2.38	2.47	2.35	2.40	2.49	2.58	2.44	2.49	2.58	2.68	
Amps	0.1	0.1	0.1	0.1	0.1	0.1	0.1	0.1	0.1	0.1	0.1	0.1	0.1	0.1	0.1	0.1	0.1	0.1	0.1	0.1	0.1	0.1	0.1	0.1	
Hi PR	207	222	235	245	232	249	263	275	264	284	300	312	300	323	341	356	338	364	384	400	373	402	424	442	
Lo PR	109	116	126	135	115	122	133	142	119	127	139	148	125	133	146	155	131	140	153	163	136	145	158	168	

Shaded area is AHRI Rating conditions IDB: Entering Indoor Dry Bulb Temperature  
 High and low pressures are measured at the liquid and suction service valves.  
 kW = Total system power  
 Design Subcooling 5 - 7 °F @ the liquid service valve, AHRI 95 test conditions  
 Amps = outdoor unit amps (comp.+fan)

EXPANDED COOLING DATA — ASZC180481A\*/CA\*F3743\*6\*\*+TXV/MBVC2000\*\* HIGH STAGE

IDB	AIRFLOW	OUTDOOR AMBIENT TEMPERATURE																							
		65°F				75°F				85°F				95°F				105°F				115°F			
		59	63	67	71	59	63	67	71	59	63	67	71	59	63	67	71	59	63	67	71	59	63	67	71
70	MBh	49.0	50.8	55.6	-	47.9	49.6	54.3	-	46.7	48.4	53.1	-	45.6	47.2	51.8	-	43.3	44.9	49.2	-	40.1	41.6	45.5	-
	S/T	0.75	0.63	0.44	-	0.78	0.65	0.45	-	0.80	0.67	0.46	-	0.83	0.69	0.48	-	0.86	0.72	0.50	-	0.87	0.72	0.50	-
	ΔT	17	15	11	-	17	15	11	-	17	15	11	-	18	15	12	-	17	15	11	-	16	14	11	-
	kW	2.88	2.94	3.04	-	3.10	3.17	3.28	-	3.31	3.38	3.49	-	3.48	3.56	3.68	-	3.63	3.72	3.84	-	3.76	3.85	3.98	-
	Amps	10.3	10.6	10.9	-	11.2	11.5	11.8	-	12.2	12.5	12.9	-	13.1	13.4	13.9	-	13.9	14.3	14.8	-	14.8	15.2	15.7	-
	Hi PR	214	231	244	-	241	259	273	-	274	295	311	-	312	335	354	-	351	377	399	-	387	417	440	-
	Lo PR	106	113	123	-	112	119	130	-	116	124	135	-	122	130	142	-	128	136	149	-	132	141	154	-
	MBh	47.6	49.3	54.0	-	46.5	48.2	52.8	-	45.4	47.0	51.5	-	44.3	45.9	50.3	-	42.0	43.6	47.7	-	38.9	40.4	44.2	-
	S/T	0.72	0.60	0.42	-	0.75	0.62	0.43	-	0.76	0.64	0.44	-	0.79	0.66	0.46	-	0.82	0.68	0.47	-	0.83	0.69	0.48	-
	ΔT	18	16	12	-	18	16	12	-	18	16	12	-	18	16	12	-	18	16	12	-	17	15	11	-
kW	2.85	2.92	3.01	-	3.08	3.15	3.25	-	3.28	3.35	3.46	-	3.45	3.53	3.65	-	3.60	3.68	3.81	-	3.73	3.82	3.95	-	
Amps	10.2	10.5	10.8	-	11.1	11.3	11.7	-	12.1	12.4	12.8	-	12.9	13.3	13.7	-	13.8	14.1	14.6	-	14.7	15.0	15.6	-	
Hi PR	212	229	241	-	238	256	271	-	271	292	308	-	309	332	351	-	347	374	395	-	384	413	436	-	
Lo PR	105	112	122	-	111	118	129	-	115	123	134	-	121	129	141	-	127	135	147	-	131	140	152	-	
MBh	43.9	45.5	49.9	-	42.9	44.4	48.7	-	41.9	43.4	47.5	-	40.8	42.3	46.4	-	38.8	40.2	44.1	-	35.9	37.3	40.8	-	
S/T	0.69	0.58	0.40	-	0.72	0.60	0.42	-	0.74	0.62	0.43	-	0.76	0.64	0.44	-	0.79	0.66	0.46	-	0.80	0.66	0.46	-	
ΔT	18	16	12	-	19	16	12	-	19	16	12	-	19	16	12	-	18	16	12	-	17	15	11	-	
kW	2.78	2.84	2.94	-	3.00	3.07	3.17	-	3.20	3.27	3.37	-	3.37	3.44	3.56	-	3.51	3.59	3.71	-	3.64	3.72	3.84	-	
Amps	9.9	10.2	10.5	-	10.7	11.0	11.4	-	11.7	12.0	12.4	-	12.6	12.9	13.3	-	13.4	13.7	14.2	-	14.2	14.6	15.1	-	
Hi PR	206	222	234	-	231	249	263	-	263	283	299	-	299	322	340	-	337	362	383	-	372	400	423	-	
Lo PR	102	108	118	-	108	114	125	-	112	119	130	-	117	125	136	-	123	131	143	-	127	135	148	-	

75	MBh	49.8	51.3	55.5	59.6	48.7	50.1	54.2	58.2	47.5	48.9	52.9	56.8	46.4	47.7	51.7	55.4	44.0	45.3	49.1	52.7	40.8	42.0	45.5	48.8
	S/T	0.86	0.77	0.58	0.37	0.89	0.79	0.60	0.39	0.91	0.81	0.62	0.40	0.94	0.84	0.64	0.41	0.98	0.87	0.66	0.42	0.98	0.88	0.67	0.43
	ΔT	20	18	15	10	20	19	15	11	20	19	15	11	20	19	15	11	20	18	15	10	19	17	14	10
	kW	2.90	2.96	3.06	3.16	3.13	3.20	3.31	3.42	3.33	3.41	3.52	3.64	3.51	3.59	3.71	3.84	3.67	3.75	3.88	4.01	3.80	3.88	4.02	4.16
	Amps	10.4	10.7	11.0	11.4	11.3	11.6	12.0	12.4	12.3	12.6	13.0	13.6	13.2	13.5	14.0	14.5	14.1	14.4	14.9	15.5	14.9	15.3	15.9	16.5
	Hi PR	217	233	246	257	243	262	276	288	277	298	314	328	315	339	358	373	354	381	403	420	391	421	445	464
	Lo PR	107	114	124	132	113	120	131	140	118	125	137	145	123	131	143	153	129	138	150	160	134	142	155	166
	MBh	48.4	49.8	53.9	57.9	47.3	48.6	52.7	56.5	46.1	47.5	51.4	55.2	45.0	46.3	50.2	53.8	42.8	44.0	47.6	51.1	39.6	40.8	44.1	47.4
	S/T	0.82	0.73	0.55	0.36	0.85	0.76	0.57	0.37	0.87	0.78	0.59	0.38	0.90	0.80	0.61	0.39	0.93	0.83	0.63	0.41	0.94	0.84	0.64	0.41
	ΔT	21	19	16	11	21	19	16	11	21	19	16	11	21	20	16	11	21	19	16	11	20	18	15	10
kW	2.88	2.94	3.04	3.14	3.11	3.17	3.28	3.39	3.31	3.38	3.49	3.61	3.48	3.56	3.68	3.81	3.63	3.72	3.84	3.98	3.76	3.85	3.98	4.12	
Amps	10.3	10.6	10.9	11.3	11.2	11.5	11.8	12.3	12.2	12.5	12.9	13.4	13.1	13.4	13.9	14.4	13.9	14.3	14.8	15.4	14.8	15.2	15.7	16.3	
Hi PR	215	231	244	254	241	259	274	285	274	295	311	324	312	336	354	370	351	377	399	416	388	417	440	459	
Lo PR	106	113	123	131	112	119	130	138	116	124	135	144	122	130	142	151	128	136	149	158	133	141	154	164	
MBh	44.7	46.0	49.8	53.4	43.6	44.9	48.6	52.2	42.6	43.8	47.4	50.9	41.5	42.8	46.3	49.7	39.5	40.6	44.0	47.2	36.6	37.6	40.7	43.7	
S/T	0.79	0.70	0.53	0.34	0.82	0.73	0.55	0.36	0.84	0.75	0.57	0.36	0.86	0.77	0.59	0.38	0.90	0.80	0.61	0.39	0.90	0.81	0.61	0.39	
ΔT	21	19	16	11	21	20	16	11	21	20	16	11	22	20	16	11	21	20	16	11	20	18	15	10	
kW	2.81	2.87	2.96	3.06	3.03	3.09	3.20	3.30	3.22	3.29	3.40	3.52	3.39	3.47	3.59	3.71	3.54	3.62	3.74	3.87	3.67	3.75	3.88	4.01	
Amps	10.0	10.3	10.6	11.0	10.9	11.1	11.5	12.0	11.8	12.1	12.6	13.0	12.7	13.0	13.5	14.0	13.5	13.9	14.4	14.9	14.4	14.7	15.2	15.9	
Hi PR	208	224	236	247	233	251	265	277	266	286	302	315	302	325	344	358	340	366	387	403	376	405	427	446	
Lo PR	103	109	119	127	109	116	126	134	113	120	131	140	119	126	138	147	124	132	144	154	129	137	149	159	

Shaded area is ACCA (TVA) conditions IDB: Entering Indoor Dry Bulb Temperature kW = Total system power Amps = outdoor unit amps (comp.+fan)  
 High and low pressures are measured at the liquid and suction service valves. Design Subcooling 5 - 7 °F @ the liquid service valve, AHR1 95 test conditions

EXPANDED COOLING DATA — ASZC180481A\*/CA\*F3743\*6\*\*+TXV/MBVC2000\*\* HIGH STAGE (CONT.)

IDB	AIRFLOW	OUTDOOR AMBIENT TEMPERATURE																							
		65°F				75°F				85°F				95°F				105°F				115°F			
		59	63	67	71	59	63	67	71	59	63	67	71	59	63	67	71	59	63	67	71	59	63	67	71
80	MBh	50.7	51.8	55.4	59.2	49.5	50.6	54.1	57.8	48.4	49.4	52.8	56.4	47.2	48.2	51.5	55.1	44.8	45.8	48.9	52.3	41.5	42.4	45.3	48.4
	S/T	0.94	0.88	0.72	0.54	1.00	0.91	0.74	0.56	1.00	0.94	0.76	0.57	1.00	0.97	0.79	0.59	1.00	1.00	0.82	0.61	1.00	1.00	0.82	0.62
	ΔT	22	21	19	15	23	22	19	15	23	22	19	15	22	22	19	15	21	21	19	15	19	20	17	14
	kW	2.93	2.99	3.09	3.19	3.16	3.23	3.33	3.45	3.36	3.44	3.55	3.67	3.54	3.62	3.75	3.87	3.70	3.78	3.91	4.05	3.83	3.92	4.05	4.19
	Amps	10.5	10.8	11.1	11.6	11.4	11.7	12.1	12.5	12.4	12.7	13.2	13.7	13.3	13.6	14.1	14.7	14.2	14.6	15.1	15.7	15.1	15.5	16.0	16.6
	Hi PR	219	236	249	259	246	264	279	291	279	301	317	331	318	342	361	377	358	385	407	424	395	426	449	469
	Lo PR	108	115	126	134	114	122	133	141	119	126	138	147	125	133	145	154	131	139	152	162	135	144	157	167
	MBh	49.2	50.3	53.8	57.5	48.1	49.1	52.5	56.1	46.9	48.0	51.3	54.8	45.8	46.8	50.0	53.5	43.5	44.5	47.5	50.8	40.3	41.2	44.0	47.0
	S/T	0.90	0.84	0.68	0.51	0.93	0.87	0.71	0.53	0.95	0.89	0.73	0.54	0.98	0.92	0.75	0.56	1.00	0.96	0.78	0.58	1.00	0.97	0.79	0.59
	ΔT	23	22	19	15	23	22	20	16	24	23	20	16	24	23	20	16	24	23	20	16	21	21	18	15
kW	2.90	2.96	3.06	3.16	3.13	3.20	3.31	3.42	3.33	3.41	3.52	3.64	3.51	3.59	3.71	3.84	3.67	3.75	3.88	4.01	3.80	3.88	4.02	4.16	
Amps	10.4	10.7	11.0	11.5	11.3	11.6	12.0	12.4	12.3	12.6	13.0	13.6	13.2	13.5	14.0	14.5	14.1	14.4	14.9	15.5	14.9	15.3	15.9	16.5	
Hi PR	217	233	246	257	243	262	276	288	277	298	314	328	315	339	358	373	354	381	403	420	391	421	445	464	
Lo PR	107	114	124	132	113	120	131	140	118	125	137	145	123	131	143	153	129	138	150	160	134	142	155	166	
MBh	45.4	46.4	49.6	53.0	44.4	45.4	48.5	51.8	43.3	44.3	47.3	50.6	42.3	43.2	46.2	49.3	40.2	41.0	43.8	46.9	37.2	38.0	40.6	43.4	
S/T	0.86	0.81	0.66	0.49	0.90	0.84	0.68	0.51	0.92	0.86	0.70	0.52	0.95	0.89	0.72	0.54	0.98	0.92	0.75	0.56	0.99	0.93	0.76	0.57	
ΔT	24	23	20	16	24	23	20	16	24	23	20	16	24	23	20	16	24	23	20	16	22	21	18	15	
kW	2.83	2.89	2.98	3.08	3.05	3.12	3.22	3.33	3.25	3.32	3.43	3.55	3.42	3.50	3.62	3.74	3.57	3.65	3.78	3.91	3.70	3.78	3.91	4.05	
Amps	10.1	10.4	10.7	11.1	11.0	11.2	11.6	12.1	11.9	12.3	12.7	13.2	12.8	13.1	13.6	14.1	13.7	14.0	14.5	15.1	14.5	14.9	15.4	16.0	
Hi PR	210	226	239	249	236	254	268	280	268	289	305	318	306	329	347	362	344	370	391	407	380	409	432	450	
Lo PR	104	110	121	128	110	117	127	136	114	121	132	141	120	127	139	148	126	134	146	155	130	138	151	161	

85	MBh	51.6	52.6	55.1	58.8	50.4	51.4	53.8	57.4	49.2	50.2	52.5	56.0	48.0	48.9	51.2	54.7	45.6	46.5	48.7	51.9	42.2	43.1	45.1	48.1
	S/T	0.99	0.95	0.86	0.70	1.00	0.99	0.89	0.72	1.00	1.00	0.91	0.74	1.00	1.00	0.94	0.76	1.00	1.00	0.98	0.79	1.00	1.00	0.99	0.80
	ΔT	24	23	22	19	24	24	22	19	23	23	22	19	22	23	23	19	21	22	22	19	20	20	21	18
	kW	2.95	3.01	3.11	3.22	3.18	3.25	3.36	3.48	3.39	3.47	3.58	3.71	3.57	3.65	3.78	3.91	3.73	3.81	3.94	4.08	3.86	3.95	4.09	4.23
	Amps	10.6	10.9	11.2	11.7	11.5	11.8	12.2	12.7	12.5	12.9	13.3	13.8	13.4	13.8	14.3	14.8	14.3	14.7	15.2	15.8	15.2	15.6	16.2	16.8
	Hi PR	221	238	251	262	248	267	282	294	282	304	321	334	321	346	365	381	361	389	411	428	399	430	454	473
	Lo PR	109	116	127	135	115	123	134	143	120	128	139	148	126	134	146	156	132	140	153	163	137	145	159	169
	MBh	50.1	51.1	53.5	57.1	48.9	49.9	52.2	55.7	47.8	48.7	51.0	54.4	46.6	47.5	49.8	53.1	44.3	45.1	47.3	50.4	41.0	41.8	43.8	46.7
	S/T	0.94	0.91	0.82	0.66	0.97	0.94	0.85	0.69	1.00	0.96	0.87	0.71	1.00	0.99	0.90	0.73	1.00	1.00	0.93	0.76	1.00	1.00	0.94	0.76
	ΔT	25	24	23	20	25	25	23	20	25	25	23	20	24	25	23	20	24	25	23	20	22	22	22	19
kW	2.93	2.99	3.09	3.19	3.16	3.23	3.33	3.45	3.36	3.44	3.55	3.67	3.54	3.62	3.75	3.87	3.70	3.78	3.91	4.05	3.83	3.92	4.05	4.19	
Amps	10.5	10.8	11.1	11.6	11.4	11.7	12.1	12.5	12.4	12.7	13.2	13.7	13.3	13.6	14.1	14.7	14.2	14.6	15.1	15.7	15.1	15.5	16.0	16.6	
Hi PR	219	236	249	259	246	264	279	291	279	301	317	331	318	342	361	377	358	385	407	424	395	426	449	469	
Lo PR	108	115	126	134	114	122	133	141	119	126	138	147	125	133	145	154	131	139	152	162	135	144	157	167	
MBh	46.2	47.1	49.4	52.7	45.2	46.0	48.2	51.4	44.1	44.9	47.1	50.2	43.0	43.8	45.9	49.0	40.9	41.7	43.6	46.5	37.9	38.6	40.4	43.1	
S/T	0.91	0.87	0.79	0.64	0.94	0.91	0.82	0.66	0.96	0.93	0.84	0.68	0.99	0.96	0.87	0.70	1.00	1.00	0.90	0.73	1.00	1.00	0.91	0.74	
ΔT	25	25	23	20	25	25	24	20	25	25	24	21	26	25	24	21	26	25	24	21	25	25	24	21	
kW	2.85	2.92	3.01	3.11	3.08	3.15	3.25	3.36	3.28	3.35	3.46	3.58	3.45	3.53	3.65	3.77	3.60	3.68	3.81	3.94	3.73	3.82	3.95	4.08	
Amps	10.2	10.5	10.8	11.2	11.1	11.3	11.7	12.2	12.1	12.4	12.8	13.3	12.9	13.3	13.7	14.3	13.8	14.1	14.6	15.2	14.6	15.0	15.5	16.2	
Hi PR	212	228	241	252	238	256	271	282	271	292	308	321	309	332	351	366	347	374	394	411	384	413	436	455	
Lo PR	105	112	122	130	111	118	129	137	115	123	134	142	121	129	140	150	127	135	147	157	131	139	152	162	

Shaded area is AHR1 Rating conditions IDB: Entering Indoor Dry Bulb Temperature kW = Total system power Amps = outdoor unit amps (comp.+fan)  
 High and low pressures are measured at the liquid and suction service valves. Design Subcooling 5 - 7 °F @ the liquid service valve, AHR1 95 test conditions

EXPANDED COOLING DATA — ASZC180601A\*/CA\*F3743\*6\*\*+TXV/MBVC2000\*\* Low STAGE

IDB	AIRFLOW	OUTDOOR AMBIENT TEMPERATURE																							
		65°F				75°F				85°F				95°F				105°F				115°F			
		59	63	67	71	59	63	67	71	59	63	67	71	59	63	67	71	59	63	67	71	59	63	67	71
70	MBh	41.6	43.1	47.2	-	40.6	42.1	46.1	-	39.7	41.1	45.0	-	38.7	40.1	43.9	-	36.8	38.1	41.7	-	34.0	35.3	38.7	-
	S/T	0.71	0.59	0.41	-	0.74	0.62	0.43	-	0.76	0.63	0.44	-	0.78	0.65	0.45	-	0.81	0.68	0.47	-	0.82	0.68	0.47	-
	ΔT	20	17	13	-	20	18	13	-	21	18	14	-	21	18	14	-	20	18	13	-	19	16	12	-
	kW	2.35	2.41	2.49	-	2.55	2.61	2.71	-	2.73	2.80	2.90	-	2.89	2.96	3.06	-	3.02	3.09	3.21	-	3.14	3.21	3.33	-
	Amps	9.1	9.4	9.7	-	9.9	10.2	10.5	-	10.8	11.1	11.5	-	11.6	11.9	12.3	-	12.3	12.7	13.1	-	13.1	13.4	13.9	-
	Hi PR	209	225	237	-	234	252	266	-	266	287	303	-	303	326	345	-	341	367	388	-	377	406	428	-
	Lo PR	105	112	122	-	111	118	129	-	115	123	134	-	121	129	141	-	127	135	147	-	131	140	152	-
	MBh	40.4	41.8	45.9	-	39.4	40.9	44.8	-	38.5	39.9	43.7	-	37.6	38.9	42.7	-	35.7	37.0	40.5	-	33.1	34.3	37.5	-
	S/T	0.68	0.57	0.39	-	0.70	0.59	0.41	-	0.72	0.60	0.42	-	0.74	0.62	0.43	-	0.77	0.65	0.45	-	0.78	0.65	0.45	-
	ΔT	21	18	14	-	21	18	14	-	21	18	14	-	21	19	14	-	21	18	14	-	20	17	13	-
kW	2.33	2.39	2.47	-	2.53	2.59	2.68	-	2.71	2.77	2.87	-	2.86	2.93	3.04	-	2.99	3.07	3.18	-	3.11	3.18	3.30	-	
Amps	9.1	9.3	9.6	-	9.8	10.1	10.4	-	10.7	11.0	11.4	-	11.5	11.8	12.2	-	12.2	12.5	13.0	-	13.0	13.3	13.8	-	
Hi PR	207	222	235	-	232	249	263	-	264	284	300	-	300	323	341	-	338	364	384	-	373	402	424	-	
Lo PR	104	111	121	-	110	117	128	-	114	121	133	-	120	128	139	-	126	134	146	-	130	138	151	-	
MBh	37.3	38.6	42.3	-	36.4	37.7	41.3	-	35.5	36.8	40.4	-	34.7	35.9	39.4	-	32.9	34.1	37.4	-	30.5	31.6	34.6	-	
S/T	0.65	0.55	0.38	-	0.68	0.57	0.39	-	0.70	0.58	0.40	-	0.72	0.60	0.42	-	0.75	0.62	0.43	-	0.75	0.63	0.43	-	
ΔT	21	18	14	-	22	19	14	-	22	19	14	-	22	19	14	-	21	19	14	-	20	17	13	-	
kW	2.27	2.32	2.40	-	2.46	2.52	2.61	-	2.63	2.70	2.79	-	2.78	2.85	2.95	-	2.91	2.98	3.09	-	3.02	3.10	3.21	-	
Amps	8.8	9.0	9.3	-	9.5	9.8	10.1	-	10.4	10.7	11.0	-	11.1	11.4	11.8	-	11.9	12.2	12.6	-	12.6	12.9	13.4	-	
Hi PR	200	216	228	-	225	242	256	-	256	275	291	-	291	313	331	-	328	353	372	-	362	390	411	-	
Lo PR	101	107	117	-	107	113	124	-	111	118	129	-	116	124	135	-	122	130	142	-	126	134	146	-	

75	MBh	42.3	43.5	47.1	50.6	41.3	42.5	46.0	49.4	40.3	41.5	44.9	48.2	39.3	40.5	43.8	47.1	37.4	38.5	41.7	44.7	34.6	35.6	38.6	41.4
	S/T	0.81	0.72	0.55	0.35	0.84	0.75	0.57	0.37	0.86	0.77	0.58	0.37	0.89	0.79	0.60	0.39	0.92	0.82	0.62	0.40	0.93	0.83	0.63	0.40
	ΔT	23	21	18	12	24	22	18	12	24	22	18	12	24	22	18	12	24	22	18	12	22	20	17	11
	kW	2.37	2.43	2.51	2.60	2.58	2.64	2.73	2.83	2.76	2.82	2.92	3.03	2.91	2.98	3.09	3.20	3.05	3.12	3.24	3.35	3.17	3.24	3.36	3.48
	Amps	9.2	9.5	9.8	10.2	10.0	10.3	10.6	11.0	10.9	11.2	11.6	12.0	11.7	12.0	12.4	12.9	12.5	12.8	13.2	13.7	13.2	13.6	14.0	14.6
	Hi PR	211	227	240	250	237	255	269	280	269	289	306	319	306	330	348	363	345	371	392	409	381	410	433	451
	Lo PR	106	113	123	131	112	119	130	139	116	124	135	144	122	130	142	151	128	136	149	159	133	141	154	164
	MBh	41.1	42.3	45.8	49.1	40.1	41.3	44.7	48.0	39.2	40.3	43.6	46.8	38.2	39.3	42.6	45.7	36.3	37.4	40.4	43.4	33.6	34.6	37.5	40.2
	S/T	0.77	0.69	0.52	0.34	0.80	0.72	0.54	0.35	0.82	0.73	0.55	0.36	0.85	0.76	0.57	0.37	0.88	0.79	0.59	0.38	0.89	0.79	0.60	0.39
	ΔT	24	22	18	13	25	23	19	13	25	23	19	13	25	23	19	13	24	22	18	13	23	21	17	12
kW	2.35	2.41	2.49	2.58	2.55	2.61	2.71	2.80	2.73	2.80	2.90	3.00	2.89	2.96	3.06	3.18	3.02	3.09	3.21	3.32	3.14	3.21	3.33	3.45	
Amps	9.1	9.4	9.7	10.1	9.9	10.2	10.5	10.9	10.8	11.1	11.5	11.9	11.6	11.9	12.3	12.8	12.3	12.7	13.1	13.6	13.1	13.4	13.9	14.5	
Hi PR	209	225	237	247	234	252	266	278	266	287	303	316	303	326	345	360	341	367	388	404	377	406	428	447	
Lo PR	105	112	122	130	111	118	129	137	115	123	134	143	121	129	141	150	127	135	147	157	131	140	152	162	
MBh	37.9	39.0	42.2	45.3	37.0	38.1	41.3	44.3	36.1	37.2	40.3	43.2	35.3	36.3	39.3	42.2	33.5	34.5	37.3	40.1	31.0	31.9	34.6	37.1	
S/T	0.74	0.67	0.50	0.32	0.77	0.69	0.52	0.34	0.79	0.71	0.54	0.34	0.82	0.73	0.55	0.36	0.85	0.76	0.57	0.37	0.85	0.76	0.58	0.37	
ΔT	25	23	19	13	25	23	19	13	25	23	19	13	25	23	19	13	25	23	19	13	23	21	17	12	
kW	2.29	2.34	2.43	2.51	2.49	2.54	2.63	2.73	2.66	2.72	2.82	2.92	2.81	2.88	2.98	3.09	2.94	3.01	3.12	3.23	3.05	3.12	3.24	3.36	
Amps	8.9	9.1	9.4	9.8	9.6	9.9	10.2	10.6	10.5	10.8	11.1	11.6	11.2	11.5	11.9	12.4	12.0	12.3	12.7	13.2	12.7	13.1	13.5	14.0	
Hi PR	202	218	230	240	227	244	258	269	258	278	294	306	294	317	334	349	331	356	376	392	366	394	416	434	
Lo PR	102	108	118	126	108	114	125	133	112	119	130	138	117	125	136	145	123	131	143	152	127	135	148	158	

Shaded area is ACCA (TVA) conditions IDB: Entering Indoor Dry Bulb Temperature kW = Total system power Amps = outdoor unit amps (comp.+fan)  
 High and low pressures are measured at the liquid and suction service valves. Design Subcooling 5 - 7 °F @ the liquid service valve, AHR1 95 test conditions

EXPANDED COOLING DATA — ASZC180601A\*/CA\*F3743\*6\*\*+TXV/MBVC2000\*\* LOW STAGE (CONT.)

IDB	AIRFLOW	OUTDOOR AMBIENT TEMPERATURE																							
		65°F				75°F				85°F				95°F				105°F				115°F			
		59	63	67	71	59	63	67	71	59	63	67	71	59	63	67	71	59	63	67	71	59	63	67	71
80	MBh	43.0	44.0	47.0	50.2	42.0	43.0	45.9	49.1	41.0	41.9	44.8	47.9	40.0	40.9	43.7	46.7	38.0	38.9	41.5	44.4	35.2	36.0	38.5	41.1
	S/T	0.89	0.83	0.68	0.51	0.92	0.86	0.70	0.52	0.94	0.88	0.72	0.54	1.00	0.91	0.74	0.56	1.00	0.95	0.77	0.58	1.00	0.96	0.78	0.58
	ΔT	26	25	22	17	26	25	22	18	27	25	22	18	27	25	22	18	26	25	22	17	24	23	20	16
	kW	2.39	2.45	2.54	2.63	2.60	2.66	2.76	2.86	2.78	2.85	2.95	3.06	2.94	3.01	3.12	3.23	3.08	3.15	3.27	3.38	3.19	3.27	3.39	3.52
	Amps	9.3	9.5	9.9	10.3	10.1	10.4	10.7	11.1	11.0	11.3	11.7	12.1	11.8	12.1	12.5	13.0	12.6	12.9	13.4	13.9	13.4	13.7	14.2	14.7
	Hi PR	213	229	242	252	239	257	271	283	272	292	309	322	309	333	352	367	348	375	396	413	385	414	437	456
	Lo PR	107	114	124	133	113	120	131	140	118	125	137	146	124	131	144	153	130	138	150	160	134	143	156	166
	MBh	41.8	42.7	45.6	48.8	40.8	41.7	44.6	47.6	39.8	40.7	43.5	46.5	38.9	39.7	42.4	45.4	36.9	37.7	40.3	43.1	34.2	35.0	37.3	39.9
	S/T	0.85	0.79	0.65	0.48	0.88	0.82	0.67	0.50	0.90	0.84	0.69	0.51	0.93	0.87	0.71	0.53	0.96	0.90	0.74	0.55	0.97	0.91	0.74	0.55
	ΔT	27	26	23	18	27	26	23	18	28	27	26	23	28	26	23	18	27	26	23	18	25	24	21	17
kW	2.37	2.43	2.51	2.60	2.58	2.64	2.73	2.83	2.76	2.82	2.92	3.03	2.91	2.98	3.09	3.20	3.05	3.12	3.24	3.35	3.17	3.24	3.36	3.48	
Amps	9.2	9.5	9.8	10.2	10.0	10.3	10.6	11.0	10.9	11.2	11.6	12.0	11.7	12.0	12.4	12.9	12.5	12.8	13.2	13.7	13.2	13.6	14.0	14.6	
Hi PR	211	227	240	250	237	255	269	280	269	290	306	319	306	330	348	363	345	371	392	409	381	410	433	451	
Lo PR	106	113	123	131	112	119	130	139	116	124	135	144	122	130	142	151	128	136	149	159	133	141	154	164	
MBh	38.6	39.4	42.1	45.0	37.7	38.5	41.1	44.0	36.8	37.6	40.2	42.9	35.9	36.7	39.2	41.9	34.1	34.8	37.2	39.8	31.6	32.3	34.5	36.9	
S/T	0.82	0.77	0.62	0.47	0.85	0.79	0.65	0.48	0.87	0.81	0.66	0.49	0.89	0.84	0.68	0.51	0.93	0.87	0.71	0.53	0.94	0.88	0.71	0.53	
ΔT	28	26	23	18	28	27	23	19	28	27	23	19	28	27	23	19	28	27	23	18	26	25	22	17	
kW	2.31	2.36	2.45	2.53	2.51	2.57	2.66	2.75	2.68	2.75	2.84	2.95	2.84	2.90	3.01	3.12	2.97	3.04	3.15	3.26	3.08	3.15	3.27	3.39	
Amps	9.0	9.2	9.5	9.9	9.7	10.0	10.3	10.7	10.6	10.9	11.2	11.7	11.4	11.6	12.0	12.5	12.1	12.4	12.8	13.4	12.9	13.2	13.6	14.2	
Hi PR	204	220	232	242	229	247	261	272	261	281	297	309	297	320	338	352	334	360	380	396	369	398	420	438	
Lo PR	103	109	120	127	109	116	126	134	113	120	131	140	119	126	138	147	124	132	144	154	129	137	149	159	

85	MBh	43.8	44.6	46.8	49.9	42.8	43.6	45.7	48.7	41.8	42.6	44.6	47.6	40.7	41.5	43.5	46.4	38.7	39.5	41.3	44.1	35.9	36.5	38.3	40.8
	S/T	0.93	0.90	0.81	0.66	0.96	0.93	0.84	0.68	0.99	0.95	0.86	0.70	1.00	0.98	0.89	0.72	1.00	1.00	0.92	0.75	1.00	1.00	0.93	0.75
	ΔT	28	27	26	22	28	28	26	23	28	28	26	23	28	28	26	23	26	27	26	22	24	25	24	21
	kW	2.42	2.47	2.56	2.65	2.62	2.69	2.78	2.88	2.81	2.87	2.98	3.08	2.97	3.04	3.15	3.26	3.10	3.18	3.30	3.42	3.22	3.30	3.42	3.55
	Amps	9.4	9.6	10.0	10.4	10.2	10.5	10.8	11.2	11.1	11.4	11.8	12.3	11.9	12.2	12.6	13.1	12.7	13.0	13.5	14.0	13.5	13.8	14.3	14.9
	Hi PR	215	231	244	255	241	260	274	286	274	295	312	325	313	336	355	370	352	378	400	417	389	418	442	460
	Lo PR	108	115	126	134	114	122	133	141	119	126	138	147	125	133	145	154	131	139	152	162	135	144	157	167
	MBh	42.5	43.3	45.4	48.4	41.5	42.3	44.3	47.3	40.5	41.3	43.3	46.2	39.6	40.3	42.2	45.1	37.6	38.3	40.1	42.8	34.8	35.5	37.2	39.6
	S/T	0.89	0.86	0.77	0.63	0.92	0.89	0.80	0.65	0.94	0.91	0.82	0.67	0.97	0.94	0.85	0.69	1.00	0.97	0.88	0.71	1.00	0.98	0.89	0.72
	ΔT	29	28	27	23	29	29	27	24	29	29	27	24	29	29	27	24	29	29	27	23	27	27	25	22
kW	2.39	2.45	2.54	2.63	2.60	2.66	2.76	2.86	2.78	2.85	2.95	3.06	2.94	3.01	3.12	3.23	3.08	3.15	3.27	3.38	3.19	3.27	3.39	3.52	
Amps	9.3	9.5	9.9	10.3	10.1	10.4	10.7	11.1	11.0	11.3	11.7	12.1	11.8	12.1	12.5	13.0	12.6	12.9	13.4	13.9	13.4	13.7	14.2	14.7	
Hi PR	213	229	242	252	239	257	271	283	272	292	309	322	309	333	352	367	348	375	396	413	385	414	437	456	
Lo PR	107	114	124	133	113	120	131	140	118	125	137	146	124	131	144	153	130	138	150	160	134	143	156	166	
MBh	39.2	40.0	41.9	44.7	38.3	39.1	40.9	43.7	37.4	38.1	40.0	42.6	36.5	37.2	39.0	41.6	34.7	35.4	37.0	39.5	32.1	32.7	34.3	36.6	
S/T	0.86	0.83	0.74	0.60	0.89	0.86	0.77	0.63	0.91	0.88	0.79	0.64	0.94	0.91	0.82	0.66	0.97	0.94	0.85	0.69	0.98	0.95	0.86	0.69	
ΔT	29.4	29	27	24	30	29	28	24	30	29	28	24	30	29	28	24	30	29	27	24	28	27	26	22	
kW	2.33	2.39	2.47	2.56	2.53	2.59	2.68	2.78	2.71	2.77	2.87	2.97	2.86	2.93	3.03	3.15	2.99	3.07	3.18	3.29	3.11	3.18	3.30	3.42	
Amps	9.1	9.3	9.6	10.0	9.8	10.1	10.4	10.8	10.7	11.0	11.3	11.8	11.5	11.8	12.2	12.6	12.2	12.5	13.0	13.5	13.0	13.3	13.8	14.3	
Hi PR	207	222	235	245	232	249	263	275	264	284	300	312	300	323	341	356	338	363	384	400	373	402	424	442	
Lo PR	104	111	121	129	110	117	128	136	114	121	133	141	120	128	139	148	126	134	146	155	130	138	151	161	

Shaded area is AHR1 Rating conditions  
 High and low pressures are measured at the liquid and suction service valves.  
 IDB: Entering Indoor Dry Bulb Temperature  
 kW = Total system power  
 Amps = outdoor unit amps (comp.+fan)  
 Design Subcooling 5 - 7 °F @ the liquid service valve, AHR1 95 test conditions



EXPANDED COOLING DATA — ASZC180601A\*/CA\*F3743\*6\*\*+TXV/MBVC2000\*\* HIGH STAGE

IDB	AIRFLOW	OUTDOOR AMBIENT TEMPERATURE																							
		65°F				75°F				85°F				95°F				105°F				115°F			
		59	63	67	71	59	63	67	71	59	63	67	71	59	63	67	71	59	63	67	71	59	63	67	71
70	MBh	55.4	57.4	62.9	-	54.1	56.1	61.4	-	52.8	54.7	59.9	-	51.5	53.4	58.5	-	48.9	50.7	55.6	-	45.3	47.0	51.5	-
	S/T	0.72	0.60	0.42	-	0.75	0.63	0.43	-	0.77	0.64	0.44	-	0.79	0.66	0.46	-	0.82	0.69	0.48	-	0.83	0.69	0.48	-
	ΔT	19	16	12	-	19	16	12	-	19	16	12	-	19	16	13	-	19	16	12	-	18	15	12	-
	kW	3.59	3.67	3.80	-	3.89	3.98	4.11	-	4.15	4.24	4.39	-	4.38	4.48	4.64	-	4.57	4.68	4.85	-	4.74	4.86	5.03	-
	Amps	7.2	7.5	8.0	-	8.3	8.7	9.2	-	9.6	10.0	10.6	-	10.8	11.2	11.8	-	11.9	12.4	13.0	-	13.0	13.5	14.2	-
	Hi PR	218	235	248	-	245	264	278	-	279	300	317	-	317	342	361	-	357	384	406	-	395	425	448	-
	Lo PR	101	107	117	-	106	113	124	-	111	118	129	-	116	124	135	-	122	130	141	-	126	134	146	-
	MBh	53.8	55.7	61.0	-	52.5	54.4	59.6	-	51.3	53.1	58.2	-	50.0	51.8	56.8	-	47.5	49.2	53.9	-	44.0	45.6	50.0	-
	S/T	0.69	0.58	0.40	-	0.71	0.60	0.41	-	0.73	0.61	0.42	-	0.76	0.63	0.44	-	0.78	0.66	0.45	-	0.79	0.66	0.46	-
	ΔT	19	17	13	-	20	17	13	-	20	17	13	-	20	17	13	-	20	17	13	-	18	16	12	-
kW	3.56	3.64	3.76	-	3.85	3.94	4.08	-	4.11	4.21	4.35	-	4.34	4.44	4.60	-	4.53	4.64	4.80	-	4.70	4.81	4.98	-	
Amps	7.1	7.4	7.9	-	8.2	8.5	9.1	-	9.5	9.9	10.4	-	10.6	11.0	11.6	-	11.7	12.2	12.8	-	12.8	13.3	14.0	-	
Hi PR	216	233	246	-	243	261	276	-	276	297	314	-	314	338	357	-	354	381	402	-	391	420	444	-	
Lo PR	100	106	116	-	105	112	122	-	110	117	127	-	115	122	134	-	121	128	140	-	125	133	145	-	
MBh	49.6	51.4	56.3	-	48.5	50.2	55.0	-	47.3	49.0	53.7	-	46.2	47.8	52.4	-	43.8	45.4	49.8	-	40.6	42.1	46.1	-	
S/T	0.66	0.55	0.38	-	0.69	0.58	0.40	-	0.71	0.59	0.41	-	0.73	0.61	0.42	-	0.76	0.63	0.44	-	0.76	0.64	0.44	-	
ΔT	20	17	13	-	20	17	13	-	20	17	13	-	20	17	13	-	20	17	13	-	19	16	12	-	
kW	3.47	3.55	3.67	-	3.75	3.84	3.97	-	4.01	4.10	4.24	-	4.23	4.33	4.47	-	4.42	4.52	4.68	-	4.58	4.69	4.85	-	
Amps	6.7	7.0	7.5	-	7.8	8.1	8.6	-	9.0	9.4	10.0	-	10.1	10.5	11.1	-	11.2	11.7	12.3	-	12.3	12.8	13.4	-	
Hi PR	210	226	238	-	235	253	267	-	268	288	304	-	305	328	346	-	343	369	390	-	379	408	431	-	
Lo PR	97	103	112	-	102	109	119	-	106	113	123	-	112	119	130	-	117	124	136	-	121	129	141	-	

75	MBh	56.3	58.0	62.7	67.3	55.0	56.6	61.3	65.8	53.7	55.3	59.8	64.2	52.4	53.9	58.4	62.6	49.8	51.2	55.5	59.5	46.1	47.5	51.4	55.1
	S/T	0.82	0.73	0.56	0.36	0.85	0.76	0.58	0.37	0.87	0.78	0.59	0.38	0.90	0.81	0.61	0.39	0.93	0.84	0.63	0.41	0.94	0.84	0.64	0.41
	ΔT	22	20	16	11	22	20	16	11	22	20	17	11	22	20	17	11	22	20	16	11	20	19	15	11
	kW	3.62	3.71	3.83	3.96	3.92	4.01	4.15	4.29	4.19	4.28	4.43	4.59	4.42	4.52	4.68	4.84	4.62	4.72	4.89	5.06	4.79	4.90	5.07	5.25
	Amps	7.3	7.7	8.1	8.7	8.5	8.8	9.4	10.0	9.8	10.2	10.8	11.4	10.9	11.4	12.0	12.7	12.1	12.5	13.2	14.0	13.2	13.7	14.4	15.2
	Hi PR	221	237	251	261	248	266	281	293	282	303	320	334	321	345	364	380	361	388	410	428	399	429	453	472
	Lo PR	102	108	118	126	108	114	125	133	112	119	130	138	117	125	136	145	123	131	143	152	127	135	148	157
	MBh	54.7	56.3	60.9	65.4	53.4	55.0	59.5	63.9	52.1	53.7	58.1	62.3	50.9	52.4	56.7	60.8	48.3	49.7	53.8	57.8	44.7	46.1	49.9	53.5
	S/T	0.78	0.70	0.53	0.34	0.81	0.73	0.55	0.35	0.83	0.74	0.56	0.36	0.86	0.77	0.58	0.37	0.89	0.80	0.60	0.39	0.90	0.80	0.61	0.39
	ΔT	22	21	17	12	23	21	17	12	23	21	17	12	23	21	17	12	23	21	17	12	21	19	16	11
kW	3.59	3.67	3.80	3.93	3.89	3.98	4.11	4.26	4.15	4.25	4.39	4.55	4.38	4.48	4.64	4.80	4.58	4.68	4.85	5.02	4.74	4.86	5.03	5.21	
Amps	7.2	7.5	8.0	8.5	8.3	8.7	9.2	9.8	9.6	10.0	10.6	11.3	10.8	11.2	11.8	12.5	11.9	12.4	13.0	13.8	13.0	13.5	14.2	15.0	
Hi PR	218	235	248	259	245	264	279	291	279	300	317	330	318	342	361	376	357	384	406	423	395	425	448	468	
Lo PR	101	107	117	125	106	113	124	132	111	118	129	137	116	124	135	144	122	130	142	151	126	134	146	156	
MBh	50.5	51.9	56.2	60.3	49.3	50.7	54.9	58.9	48.1	49.5	53.6	57.5	46.9	48.3	52.3	56.1	44.6	45.9	49.7	53.3	41.3	42.5	46.0	49.4	
S/T	0.76	0.68	0.51	0.33	0.78	0.70	0.53	0.34	0.80	0.72	0.54	0.35	0.83	0.74	0.56	0.36	0.86	0.77	0.58	0.37	0.87	0.78	0.59	0.38	
ΔT	23	21	17	12	23	21	17	12	23	21	17	12	23	21	18	12	23	21	17	12	21	20	16	11	
kW	3.50	3.58	3.70	3.83	3.79	3.87	4.01	4.14	4.04	4.13	4.28	4.43	4.26	4.36	4.52	4.67	4.45	4.56	4.72	4.89	4.62	4.73	4.89	5.07	
Amps	6.8	7.1	7.6	8.1	7.9	8.3	8.8	9.3	9.2	9.6	10.1	10.8	10.3	10.7	11.3	12.0	11.4	11.8	12.5	13.2	12.5	13.0	13.6	14.4	
Hi PR	212	228	241	251	238	256	270	282	270	291	307	320	308	331	350	365	346	373	394	411	383	412	435	454	
Lo PR	98	104	114	121	103	110	120	128	107	114	125	133	113	120	131	139	118	126	137	146	122	130	142	151	

Shaded area is ACCA (TVA) conditions IDB: Entering Indoor Dry Bulb Temperature kW = Total system power Amps = outdoor unit amps (comp.+fan)  
 High and low pressures are measured at the liquid and suction service valves. Design Subcooling 5 - 7 °F @ the liquid service valve, AHR1 95 test conditions



EXPANDED COOLING DATA — ASZC180601A\*/CA\*F3743\*6\*\*+TXV/MBVC2000\*\* HIGH STAGE (CONT.)

IDB	AIRFLOW	OUTDOOR AMBIENT TEMPERATURE																							
		65°F				75°F				85°F				95°F				105°F				115°F			
		59	63	67	71	59	63	67	71	59	63	67	71	59	63	67	71	59	63	67	71	59	63	67	71
1969	MBh	57.3	58.6	62.6	66.9	56.0	57.2	61.1	65.3	54.6	55.8	59.6	63.8	53.3	54.5	58.2	62.2	50.6	51.7	55.3	59.1	46.9	47.9	51.2	54.7
	S/T	0.90	0.84	0.69	0.51	0.93	0.88	0.71	0.53	0.96	0.90	0.73	0.55	1.00	0.93	0.75	0.56	1.00	0.96	0.78	0.59	1.00	0.97	0.79	0.59
	ΔT	24	23	20	16	24	23	20	16	25	24	20	16	25	24	20	16	24	23	20	16	22	22	19	15
	kW	3.65	3.74	3.86	4.00	3.96	4.05	4.19	4.33	4.22	4.32	4.47	4.63	4.46	4.56	4.72	4.89	4.66	4.77	4.93	5.11	4.83	4.94	5.12	5.30
	Amps	7.4	7.8	8.3	8.8	8.6	9.0	9.5	10.1	9.9	10.4	10.9	11.6	11.1	11.5	12.2	12.9	12.3	12.7	13.4	14.2	13.4	13.9	14.6	15.4
	Hi PR	223	240	253	264	250	269	284	296	284	306	323	337	324	349	368	384	364	392	414	432	403	433	458	477
	Lo PR	103	109	119	127	109	116	126	134	113	120	131	140	119	126	138	147	124	132	144	154	129	137	149	159
	MBh	55.6	56.9	60.7	64.9	54.3	55.5	59.3	63.4	53.0	54.2	57.9	61.9	51.8	52.9	56.5	60.4	49.2	50.2	53.7	57.4	45.5	46.5	49.7	53.2
	S/T	0.86	0.81	0.66	0.49	0.89	0.83	0.68	0.51	0.91	0.86	0.70	0.52	0.94	0.88	0.72	0.54	0.98	0.92	0.75	0.56	0.99	0.92	0.75	0.56
	ΔT	25	24	21	17	25	24	21	17	25	24	21	17	26	25	21	17	25	24	21	17	24	23	20	16
1750	kW	3.62	3.71	3.83	3.96	3.92	4.01	4.15	4.29	4.19	4.28	4.43	4.59	4.42	4.52	4.68	4.85	4.62	4.73	4.89	5.06	4.79	4.90	5.07	5.25
	Amps	7.3	7.7	8.1	8.7	8.5	8.8	9.4	10.0	9.8	10.2	10.8	11.4	10.9	11.4	12.0	12.7	12.1	12.6	13.2	14.0	13.2	13.7	14.4	15.2
	Hi PR	221	237	251	262	248	266	281	293	282	303	320	334	321	345	364	380	361	388	410	428	399	429	453	472
	Lo PR	102	108	118	126	108	114	125	133	112	119	130	138	117	125	136	145	123	131	143	152	127	135	148	157
	MBh	51.4	52.5	56.1	59.9	50.2	51.3	54.8	58.5	49.0	50.0	53.5	57.1	47.8	48.8	52.1	55.7	45.4	46.4	49.5	53.0	42.0	43.0	45.9	49.1
	S/T	0.83	0.78	0.63	0.47	0.86	0.81	0.66	0.49	0.88	0.83	0.67	0.50	0.91	0.85	0.69	0.52	0.94	0.88	0.72	0.54	0.95	0.89	0.73	0.54
	ΔT	26	24	21	17	26	25	22	17	26	25	22	17	26	25	22	17	26	25	21	17	24	23	20	16
	kW	3.53	3.61	3.73	3.86	3.82	3.91	4.04	4.18	4.08	4.17	4.31	4.47	4.30	4.40	4.56	4.72	4.49	4.60	4.76	4.93	4.66	4.77	4.94	5.11
	Amps	6.9	7.3	7.7	8.3	8.0	8.4	8.9	9.5	9.3	9.7	10.3	10.9	10.4	10.9	11.5	12.2	11.6	12.0	12.6	13.4	12.7	13.1	13.8	14.6
	Hi PR	214	230	243	254	240	258	273	285	273	294	310	324	311	335	354	369	350	377	398	415	387	416	439	458
Lo PR	99	105	115	122	104	111	121	129	108	115	126	134	114	121	132	141	119	127	139	148	123	131	143	153	

1969	MBh	58.3	59.4	62.2	66.4	56.9	58.1	60.8	64.9	55.6	56.7	59.4	63.3	54.2	55.3	57.9	61.8	51.5	52.5	55.0	58.7	47.7	48.7	51.0	54.4
	S/T	0.94	0.91	0.82	0.67	0.98	0.94	0.85	0.69	1.00	0.97	0.87	0.71	1.00	0.90	0.80	0.73	1.00	0.90	0.80	0.76	1.00	0.90	0.94	0.77
	ΔT	26	25	24	21	26	26	24	21	25	26	24	21	25	26	24	21	24	25	24	21	22	23	22	19
	kW	3.69	3.77	3.90	4.03	3.99	4.08	4.22	4.37	4.26	4.36	4.51	4.67	4.50	4.60	4.76	4.93	4.70	4.81	4.98	5.16	4.87	4.99	5.16	5.35
	Amps	7.6	7.9	8.4	9.0	8.7	9.1	9.7	10.3	10.1	10.5	11.1	11.8	11.3	11.7	12.3	13.1	12.4	12.9	13.6	14.4	13.6	14.1	14.8	15.6
	Hi PR	225	242	256	267	253	272	287	299	287	309	326	340	327	352	372	388	368	396	418	436	407	438	462	482
	Lo PR	104	111	121	128	110	117	127	136	114	121	132	141	120	127	139	148	126	134	146	155	130	138	151	161
	MBh	56.6	57.7	60.4	64.5	55.3	56.4	59.0	63.0	54.0	55.0	57.6	61.5	52.7	53.7	56.2	60.0	50.0	51.0	53.4	57.0	46.3	47.2	49.5	52.8
	S/T	0.90	0.87	0.78	0.64	0.93	0.90	0.81	0.66	0.96	0.92	0.83	0.68	0.99	0.95	0.86	0.70	1.00	0.99	0.89	0.72	1.00	0.90	0.90	0.73
	ΔT	27	26	25	22	27	27	25	22	27	27	25	22	27	27	25	22	27	27	25	22	24	25	23	20
1750	kW	3.65	3.74	3.86	4.00	3.96	4.05	4.19	4.33	4.22	4.32	4.47	4.63	4.46	4.56	4.72	4.89	4.66	4.77	4.93	5.11	4.83	4.94	5.12	5.30
	Amps	7.4	7.8	8.3	8.8	8.6	9.0	9.5	10.1	9.9	10.4	10.9	11.6	11.1	11.5	12.2	12.9	12.3	12.7	13.4	14.2	13.4	13.9	14.6	15.4
	Hi PR	223	240	253	264	250	269	284	296	284	306	323	337	324	349	368	384	364	392	414	432	403	433	458	477
	Lo PR	103	109	119	127	109	116	126	134	113	120	131	140	119	126	138	147	124	132	144	154	129	137	149	159
	MBh	52.2	53.3	55.8	59.5	51.0	52.0	54.5	58.1	49.8	50.8	53.2	56.7	48.6	49.5	51.9	55.4	46.2	47.1	49.3	52.6	42.8	43.6	45.7	48.7
	S/T	0.87	0.84	0.76	0.61	0.90	0.87	0.78	0.64	0.92	0.89	0.80	0.65	0.95	0.92	0.83	0.67	0.99	0.95	0.86	0.70	1.00	0.96	0.87	0.70
	ΔT	27	27	25	22	28	27	26	22	28	27	26	22	28	27	26	22	27	27	25	22	26	25	24	21
	kW	3.56	3.64	3.76	3.89	3.85	3.94	4.08	4.22	4.11	4.21	4.35	4.50	4.34	4.44	4.60	4.76	4.53	4.64	4.80	4.97	4.70	4.81	4.98	5.16
	Amps	7.1	7.4	7.9	8.4	8.2	8.5	9.1	9.6	9.5	9.9	10.4	11.1	10.6	11.0	11.6	12.3	11.7	12.2	12.8	13.6	12.8	13.3	14.0	14.8
	Hi PR	216	233	246	256	243	261	276	287	276	297	313	327	314	338	357	372	353	380	402	419	391	420	444	463
Lo PR	100	106	116	123	105	112	122	130	110	117	127	135	115	122	134	142	121	128	140	149	125	133	145	154	

Shaded area is AHR1 Rating conditions IDB: Entering Indoor Dry Bulb Temperature  
 High and low pressures are measured at the liquid and suction service valves.  
 kW = Total system power  
 Design Subcooling 5 - 7 °F @ the liquid service valve, AHR1 95 test conditions  
 Amps = outdoor unit amps (comp.+fan)

## EXPANDED HEATING DATA — LOW STAGE

ASZC180361A\* / CA\*F3743\*6\*\*+TXV/ MBVC1600\*\*-1

	OUTDOOR AMBIENT TEMPERATURE																	
	65	60	55	50	47	45	40	35	30	25	20	17	15	10	5	0	-5	-10
MBh	30.8	29.2	27.4	25.6	24.5	23.7	22.0	20.3	18.0	16.6	15.3	14.5	13.9	12.5	11.1	9.7	8.3	6.8
ΔT	33.5	31.8	29.9	27.9	26.7	25.9	24.0	22.1	19.6	18.1	16.7	15.8	15.2	13.6	12.1	10.5	9.0	7.4
kW	1.98	1.94	1.90	1.86	1.8	1.81	1.77	1.73	1.78	1.74	1.69	1.67	1.65	1.60	1.56	1.51	1.47	1.42
Amps	9.5	8.8	8.2	7.7	7.5	7.3	6.9	6.5	6.2	6.0	5.7	5.5	5.5	5.2	4.8	4.5	4.2	3.7
COP	4.54	4.39	4.23	4.04	3.91	3.83	3.64	3.44	2.96	2.81	2.65	2.54	2.48	2.28	2.08	1.87	1.64	1.39
EER	15.5	15.0	14.4	13.8	13.4	13.1	12.4	11.7	10.1	9.6	9.1	8.7	8.5	7.8	7.1	6.4	5.6	4.7
HI PR	393	377	362	346	338	332	319	306	293	280	269	262	258	248	238	229	221	213
LO PR	145	134	126	116	109	105	97	86	78	69	61	57	55	46	40	34	29	23

ASZC180481A\* / CA\*F4961\*6\*\*+TXV/ MBVC2000\*\*-1

	OUTDOOR AMBIENT TEMPERATURE																	
	65	60	55	50	47	45	40	35	30	25	20	17	15	10	5	0	-5	-10
MBh	43.8	41.4	39.0	36.5	34.8	33.7	31.3	28.9	27.0	25.0	23.0	21.7	20.9	18.7	16.6	14.5	12.4	10.1
ΔT	33.8	32.0	30.1	28.1	26.9	26.0	24.2	22.3	20.9	19.3	17.7	16.7	16.1	14.5	12.8	11.2	9.5	7.8
kW	2.67	2.62	2.56	2.50	2.5	2.44	2.39	2.33	2.44	2.38	2.32	2.28	2.26	2.19	2.13	2.07	2.01	1.95
Amps	12.7	11.7	10.9	10.2	9.8	9.6	9.0	8.5	8.1	7.7	7.2	7.0	6.9	6.5	6.0	5.6	5.1	4.5
COP	4.79	4.63	4.46	4.27	4.13	4.04	3.84	3.63	3.24	3.07	2.90	2.78	2.71	2.50	2.28	2.05	1.80	1.52
EER	16.4	15.8	15.2	14.6	14.1	13.8	13.1	12.4	11.1	10.5	9.9	9.5	9.3	8.5	7.8	7.0	6.2	5.2
HI PR	391	375	360	344	336	330	317	304	292	278	267	261	256	247	237	227	219	212
LO PR	145	134	126	115	109	105	97	86	78	69	61	57	55	46	40	34	29	23

ASZC180601A\* / CA\*F4961\*6\*\*+TXV/ MBVC2000\*\*-1

	OUTDOOR AMBIENT TEMPERATURE																	
	65	60	55	50	47	45	40	35	30	25	20	17	15	10	5	0	-5	-10
MBh	52.0	49.2	46.3	43.3	41.4	40.1	37.2	34.3	32.6	30.1	27.7	26.1	25.2	22.6	20.0	17.5	14.9	12.2
ΔT	40.1	38.0	35.7	33.4	31.9	30.9	28.7	26.5	25.1	23.2	21.4	20.2	19.4	17.4	15.5	13.5	11.5	9.4
kW	3.66	3.58	3.50	3.42	3.4	3.34	3.26	3.18	3.23	3.15	3.06	3.01	2.98	2.90	2.81	2.73	2.65	2.57
Amps	17.5	16.2	15.1	14.2	13.6	13.4	12.6	11.9	11.3	10.8	10.3	10.0	9.8	9.3	8.6	8.1	7.4	6.6
COP	4.16	4.02	3.87	3.71	3.59	3.51	3.34	3.16	2.95	2.80	2.64	2.54	2.47	2.28	2.08	1.87	1.65	1.39
EER	14.2	13.7	13.2	12.7	12.3	12.0	11.4	10.8	10.1	9.6	9.0	8.7	8.4	7.8	7.1	6.4	5.6	4.8
HI PR	421	403	388	371	362	355	341	328	314	300	288	281	276	265	255	245	236	228
LO PR	138	128	120	110	104	100	92	82	74	66	58	54	52	44	38	32	28	22

High pressure is measured at the suction service valve ( the larger valve).  
 Low pressure is measured at the gauge port connection.  
 Calculations are based on nominal CFM and 70 °F indoor dry bulb.

Amps = Outdoor unit amps (comp.+fan)  
 kW = Total system power

## EXPANDED HEATING DATA — HIGH STAGE

ASZC180361A\* / CA\*F3743\*6\*\*+TXV/ MBVC1600\*\*-1

	OUTDOOR AMBIENT TEMPERATURE																	
	65	60	55	50	47	45	40	35	30	25	20	17	15	10	5	0	-5	-10
MBh	44.5	42.2	39.7	37.1	35.4	34.3	31.9	29.4	27.5	25.4	23.4	22.0	21.2	19.1	16.9	14.7	12.6	10.3
ΔT	33.0	31.2	29.4	27.5	26.2	25.4	23.6	21.8	20.4	18.8	17.3	16.3	15.7	14.1	12.5	10.9	9.3	7.6
kW	2.81	2.75	2.69	2.63	2.6	2.57	2.52	2.46	2.43	2.37	2.32	2.28	2.26	2.20	2.14	2.08	2.02	1.97
Amps	12.8	11.8	11.1	10.4	10.0	9.8	9.2	8.7	8.3	8.0	7.6	7.4	7.3	6.9	6.4	6.0	5.5	4.9
COP	4.64	4.49	4.32	4.12	3.99	3.90	3.71	3.50	3.30	3.13	2.95	2.83	2.75	2.54	2.31	2.07	1.82	1.53
EER	15.9	15.3	14.8	14.1	13.6	13.3	12.7	12.0	11.3	10.7	10.1	9.7	9.4	8.7	7.9	7.1	6.2	5.2
HI PR	400	383	369	352	344	338	324	311	298	285	274	267	262	252	243	233	224	216
LO PR	143	132	124	114	108	104	95	85	77	68	60	56	54	46	39	33	29	23

ASZC180481A\* / CA\*F4961\*6\*\*+TXV/ MBVC2000\*\*-1

	OUTDOOR AMBIENT TEMPERATURE																	
	65	60	55	50	47	45	40	35	30	25	20	17	15	10	5	0	-5	-10
MBh	62.2	58.9	55.4	51.8	49.5	48.0	44.6	41.1	38.9	35.9	33.0	31.2	30.0	27.0	23.9	20.8	17.8	14.6
ΔT	32.9	31.2	29.3	27.4	26.2	25.4	23.6	21.7	20.6	19.0	17.5	16.5	15.9	14.3	12.6	11.0	9.4	7.7
kW	3.80	3.72	3.64	3.56	3.5	3.49	3.41	3.33	3.28	3.20	3.12	3.07	3.04	2.96	2.89	2.81	2.73	2.66
Amps	17.0	15.7	14.7	13.8	13.2	13.0	12.2	11.5	11.0	10.5	10.0	9.7	9.6	9.1	8.4	7.9	7.2	6.4
COP	4.80	4.64	4.46	4.26	4.12	4.03	3.82	3.61	3.47	3.29	3.10	2.97	2.89	2.66	2.42	2.17	1.90	1.61
EER	16.4	15.8	15.2	14.5	14.1	13.8	13.1	12.3	11.9	11.2	10.6	10.2	9.9	9.1	8.3	7.4	6.5	5.5
HI PR	398	382	367	351	343	336	323	310	297	284	272	266	261	251	241	232	223	215
LO PR	137	127	119	109	103	99	91	81	73	65	57	53	51	44	38	32	28	22

ASZC180601A\* / CA\*F4961\*6\*\*+TXV/ MBVC2000\*\*-1

	OUTDOOR AMBIENT TEMPERATURE																	
	65	60	55	50	47	45	40	35	30	25	20	17	15	10	5	0	-5	-10
MBh	71.6	67.8	63.8	59.7	57.0	55.2	51.3	47.3	46.7	43.1	39.7	37.5	36.1	32.4	28.7	25.0	21.4	17.5
ΔT	37.9	35.9	33.8	31.6	30.2	29.2	27.1	25.0	24.7	22.8	21.0	19.8	19.1	17.1	15.2	13.2	11.3	9.3
kW	4.94	4.84	4.73	4.63	4.6	4.52	4.42	4.32	4.28	4.17	4.07	4.00	3.96	3.85	3.75	3.65	3.54	3.44
Amps	24.5	22.1	20.2	18.6	17.6	17.1	15.7	14.5	13.6	12.6	11.7	11.2	10.9	10.0	8.8	7.9	6.7	5.3
COP	4.24	4.10	3.95	3.77	3.65	3.57	3.40	3.21	3.19	3.02	2.86	2.74	2.66	2.46	2.24	2.01	1.77	1.49
EER	14.5	14.0	13.5	12.9	12.5	12.2	11.6	11.0	10.9	10.3	9.8	9.4	9.1	8.4	7.7	6.9	6.0	5.1
HI PR	421	403	388	371	362	355	342	328	314	300	288	281	276	265	255	245	236	228
LO PR	127	118	111	102	96	92	85	76	68	61	54	50	48	41	35	30	26	20

High pressure is measured at the suction service valve ( the larger valve).  
 Low pressure is measured at the gauge port connection.  
 Calculations are based on nominal CFM and 70 °F indoor dry bulb.

Amps = Outdoor unit amps (comp.+fan)  
 kW = Total system power

# AHRI PERFORMANCE RATINGS

OUTDOOR UNIT	INDOOR UNITS		COOLING CAPACITY (BTU/H)				TVA RATINGS <sup>3</sup>		HEATING CAPACITY			AHRI #
	COILS & AIR HANDLERS	FURNACE/BLOWER	TOTAL	SENS.	SEER <sup>1</sup>	EER <sup>2</sup>	TOTAL	SENS.	HIGH	HSPF <sup>4</sup>	LOW	
ASZC18 0361A*	AEPF313716A*+TXV		35,000	26,600	18	13	32,400	26,200	35,000	9.25	20,400	3610827
	AEPF426016C*+TXV		35,000	26,600	18	13	32,400	26,200	35,000	9.25	20,400	3610828
	CA*F3743*6A*+TXV	MBE1600**-1B*	35,000	26,600	18	13	32,400	26,200	35,000	9.5	20,400	3610829
	CA*F3743*6A*+TXV	MBE2000**-1B*	35,000	26,600	18	13	32,400	26,200	35,000	9.25	20,400	3610830
	CA*F3743*6A*+TXV	MBVC1600**-1A*	35,000	26,600	18	13	32,400	26,200	35,000	9.5	20,400	3611066
	CA*F3743*6A*+TXV	MBVC2000**-1A*	35,000	26,600	18	13	32,400	26,200	35,000	9.25	20,400	3611067
	CA*F3743*6A*+TXV	A*V80704B**	34,600	26,300	17.5	12.5	32,000	25,900	35,000	9.25	20,000	3610737
	CA*F3743*6A*+TXV	A*V80905C**	34,600	26,300	17.5	12.5	32,000	25,900	35,000	9.25	20,000	3610738
	CA*F3743*6A*+TXV	A*V81155C**	34,600	26,300	17.5	12.5	32,000	25,900	35,000	9.25	20,000	3610739
	CA*F3743*6A*+TXV	A*V90453B**	34,600	26,300	17.5	12.5	32,000	25,900	35,000	9.25	20,000	3610740
	CA*F3743*6A*+TXV	A*VC950453BXA*	34,600	26,300	17.5	12.5	32,000	25,900	35,000	9.25	20,000	3610741
	CA*F3743*6A*+TXV	G*V90704C**	34,600	26,300	17	12.5	32,000	25,900	35,000	9	20,400	3610742
	CA*F3743*6A*+TXV	G*V950704C**	34,600	26,300	17.5	12.5	32,000	25,900	35,000	9.25	20,000	3610743
	CA*F3743*6A*+TXV	G*VC90704CXA*	34,600	26,300	17	12.5	32,000	25,900	35,000	9	20,400	3610744
	CA*F3743*6A*+TXV	G*VC950704CXA*	34,600	26,300	17.5	12.5	32,000	25,900	35,000	9.25	20,000	3610745
	CA*F3743*6A*+TXV	A*V90905D**	35,000	26,600	18	13	32,400	26,200	35,000	9.25	20,400	3610831
	CA*F3743*6A*+TXV	A*V91155D**	35,000	26,600	18	13	32,400	26,200	35,000	9.25	20,400	3610832
	CA*F3743*6A*+TXV	A*VC90905DXA*	35,000	26,600	18	13	32,400	26,200	35,000	9.25	20,400	3610833
	CA*F3743*6A*+TXV	A*VC950905DXA*	35,000	26,600	18	13	32,400	26,200	35,000	9.25	20,400	3610834
	CA*F3743*6A*+TXV	A*VC951155DXA*	35,000	26,600	18	13	32,400	26,200	35,000	9.25	20,400	3610835
	CA*F3743*6A*+TXV	G*V950905D**	35,000	26,600	18	13	32,400	26,200	35,000	9.25	20,400	3610836
	CA*F3743*6A*+TXV	G*V951155D**	35,000	26,600	18	13	32,400	26,200	35,000	9.25	20,400	3610837
	CA*F3743*6A*+TXV	G*VC950905DXA*	35,000	26,600	18	13	32,400	26,200	35,000	9.25	20,400	3610838
	CA*F3743*6A*+TXV	G*VC951155DXA*	35,000	26,600	18	13	32,400	26,200	35,000	9.25	20,400	3610839
	CA*F3743*6A*+TXV	A*VC81155CXA*	34,600	26,300	17.5	12.5	32,000	25,900	35,000	9.25	20,000	3642833
	CA*F4860*6B*+TXV	A*V80905C**	35,000	26,600	17.5	12.5	32,400	26,200	35,000	9.25	20,000	3610853
	CA*F4961*6A*+TXV	MBE1600**-1B*	35,000	26,600	18	13	32,400	26,200	35,000	9.5	20,000	3610854
	CA*F4961*6A*+TXV	MBE2000**-1B*	35,000	26,600	18	13	32,400	26,200	35,000	9.25	20,400	3610855
	CA*F4961*6A*+TXV	MBVC1600**-1A*	35,000	26,600	18	13	32,400	26,200	35,000	9.5	20,000	3611068
	CA*F4961*6A*+TXV	MBVC2000**-1A*	35,000	26,600	18	13	32,400	26,200	35,000	9.25	20,400	3611069
	CA*F4961*6A*+TXV	A*V80704B**	34,600	26,300	17.5	12.5	32,000	25,900	35,000	9.25	20,000	3610746
	CA*F4961*6A*+TXV	A*V80905C**	34,600	26,300	17.5	12.5	32,000	25,900	35,000	9.25	20,000	3610747
	CA*F4961*6A*+TXV	A*V81155C**	34,600	26,300	17.5	12.5	32,000	25,900	35,000	9.25	20,000	3610748
	CA*F4961*6A*+TXV	A*V90453B**	34,600	26,300	17.5	12.5	32,000	25,900	35,000	9.25	20,000	3610749
	CA*F4961*6A*+TXV	A*V90704C**	34,600	26,300	17.5	12.5	32,000	25,900	35,000	9.25	20,000	3610750
	CA*F4961*6A*+TXV	A*VC90704CXA*	34,600	26,300	17.5	12.5	32,000	25,900	35,000	9.25	20,000	3610751
	CA*F4961*6A*+TXV	A*VC950453BXA*	34,600	26,300	17.5	12.5	32,000	25,900	35,000	9.25	20,000	3610752
	CA*F4961*6A*+TXV	A*VC950704CXA*	34,600	26,300	17.5	12.5	32,000	25,900	35,000	9.25	20,000	3610753
	CA*F4961*6A*+TXV	A*V90905D**	35,000	26,600	18	13	32,400	26,200	35,000	9.25	20,000	3610856
	CA*F4961*6A*+TXV	A*V91155D**	35,000	26,600	18	13	32,400	26,200	35,000	9.25	20,000	3610857
	CA*F4961*6A*+TXV	A*VC90905DXA*	35,000	26,600	18	13	32,400	26,200	35,000	9.25	20,000	3610858
	CA*F4961*6A*+TXV	A*VC950905DXA*	35,000	26,600	18	13	32,400	26,200	35,000	9.25	20,000	3610859
	CA*F4961*6A*+TXV	A*VC951155DXA*	35,000	26,600	18	13	32,400	26,200	35,000	9.25	20,000	3610860
	CA*F4961*6A*+TXV	A*VC81155CXA*	34,600	26,300	17.5	12.5	32,000	25,900	35,000	9.25	20,000	3642834
	CHPF3743C6B*+TXV	MBE1600**-1B*	35,000	26,600	18	13	32,400	26,200	35,000	9.5	20,400	3610861

See Notes on Page 21.

# AHRI PERFORMANCE RATINGS (CONT.)

OUTDOOR UNIT	INDOOR UNITS		COOLING CAPACITY (BTU/H)				TVA RATINGS <sup>3</sup>		HEATING CAPACITY			AHRI #
	COILS & AIR HANDLERS	FURNACE/BLOWER	TOTAL	SENS.	SEER <sup>1</sup>	EER <sup>2</sup>	TOTAL	SENS.	HIGH	HSPF <sup>4</sup>	LOW	
ASZC18 0361A* (cont.)	CHPF3743C6B*+TXV	MBVC1600**-1A*	35,000	26,600	18	13	32,400	26,200	35,000	9.5	20,400	3611070
	CHPF3743C6B*+TXV	A*V80704B**	34,600	26,300	17.5	12.5	32,000	25,900	35,000	9.25	20,000	3610767
	CHPF3743C6B*+TXV	A*V80905C**	34,600	26,300	17.5	12.5	32,000	25,900	35,000	9.25	20,000	3610768
	CHPF3743C6B*+TXV	A*V81155C**	34,600	26,300	17.5	12.5	32,000	25,900	35,000	9.25	20,000	3610769
	CHPF3743C6B*+TXV	A*V90453B**	34,600	26,300	17.5	12.5	32,000	25,900	35,000	9.25	20,000	3610770
	CHPF3743C6B*+TXV	A*V90704C**	34,600	26,300	17.5	12.5	32,000	25,900	35,000	9.25	20,000	3610771
	CHPF3743C6B*+TXV	A*VC90704CXA*	34,600	26,300	17.5	12.5	32,000	25,900	35,000	9.25	20,000	3610772
	CHPF3743C6B*+TXV	A*VC950453BXA*	34,600	26,300	17.5	12.5	32,000	25,900	35,000	9.25	20,000	3610773
	CHPF3743C6B*+TXV	A*VC950704CXA*	34,600	26,300	17.5	12.5	32,000	25,900	35,000	9.25	20,000	3610774
	CHPF3743C6B*+TXV	A*VC81155CXA*	34,600	26,300	17.5	12.5	32,000	25,900	35,000	9.25	20,000	3642835
	CHPF3743D6B*+TXV	MBE2000**-1B*	35,000	26,600	18	13	32,400	26,200	35,000	9.25	20,000	3610863
	CHPF3743D6B*+TXV	MBVC2000**-1A*	35,000	26,600	18	13	32,400	26,200	35,000	9.25	20,000	3611071
	CHPF3743D6B*+TXV	A*V80905C**	34,600	26,300	17.5	12.5	32,000	25,900	35,000	9.25	20,000	3610790
	CHPF3743D6B*+TXV	A*V81155C**	34,600	26,300	17.5	12.5	32,000	25,900	35,000	9.25	20,000	3610791
	CHPF3743D6B*+TXV	A*V90704C**	34,600	26,300	17.5	12.5	32,000	25,900	35,000	9.25	20,000	3610792
	CHPF3743D6B*+TXV	A*VC90704CXA*	34,600	26,300	17.5	12.5	32,000	25,900	35,000	9.25	20,000	3610793
	CHPF3743D6B*+TXV	A*VC950704CXA*	34,600	26,300	17.5	12.5	32,000	25,900	35,000	9.25	20,000	3610794
	CHPF3743D6B*+TXV	A*V90905D**	35,000	26,600	18	13	32,400	26,200	35,000	9.25	20,400	3610864
	CHPF3743D6B*+TXV	A*V91155D**	35,000	26,600	18	13	32,400	26,200	35,000	9.25	20,000	3610865
	CHPF3743D6B*+TXV	A*VC90905DXA*	35,000	26,600	18	13	32,400	26,200	35,000	9.25	20,400	3610866
	CHPF3743D6B*+TXV	A*VC950905DXA*	35,000	26,600	18	13	32,400	26,200	35,000	9.25	20,400	3610867
	CHPF3743D6B*+TXV	A*VC951155DXA*	35,000	26,600	18	13	32,400	26,200	35,000	9.25	20,000	3610868
	CHPF3743D6B*+TXV	A*VC81155CXA*	34,600	26,300	17.5	12.5	32,000	25,900	35,000	9.25	20,000	3642836
	CHPF4860D6D*+TXV	MBE2000**-1B*	35,000	26,600	18	13	32,400	26,200	35,000	9.25	20,000	3610869
	CHPF4860D6D*+TXV	MBVC2000**-1A*	35,000	26,600	18	13	32,400	26,200	35,000	9.25	20,000	3611072
	CHPF4860D6D*+TXV	A*V80905C**	34,600	26,300	17.5	12.5	32,000	25,900	35,000	9.25	20,000	3610795
	CHPF4860D6D*+TXV	A*V81155C**	34,600	26,300	17.5	12.5	32,000	25,900	35,000	9.25	20,000	3610796
	CHPF4860D6D*+TXV	A*V90704C**	34,600	26,300	17.5	12.5	32,000	25,900	35,000	9.25	20,000	3610797
	CHPF4860D6D*+TXV	A*VC90704CXA*	34,600	26,300	17.5	12.5	32,000	25,900	35,000	9.25	20,000	3610798
	CHPF4860D6D*+TXV	A*VC950704CXA*	34,600	26,300	17.5	12.5	32,000	25,900	35,000	9.25	20,000	3610799
	CHPF4860D6D*+TXV	A*V90905D**	35,000	26,600	18	13	32,400	26,200	35,000	9.25	20,000	3610870
	CHPF4860D6D*+TXV	A*V91155D**	35,000	26,600	18	13	32,400	26,200	35,000	9.25	20,000	3610871
	CHPF4860D6D*+TXV	A*VC90905DXA*	35,000	26,600	18	13	32,400	26,200	35,000	9.25	20,000	3610872
	CHPF4860D6D*+TXV	A*VC950905DXA*	35,000	26,600	18	13	32,400	26,200	35,000	9.25	20,000	3610873
	CHPF4860D6D*+TXV	A*VC951155DXA*	35,000	26,600	18	13	32,400	26,200	35,000	9.25	20,000	3610874
	CHPF4860D6D*+TXV	A*VC81155CXA*	34,600	26,300	17.5	12.5	32,000	25,900	35,000	9.25	20,000	3642837
	CHTF3743C6A*+TXV	MBVC1600**-1A*	34,600	26,300	18	13	32,000	25,900	35,000	9.5	20,400	3611073
	CHTF3743D6A*+TXV	MBVC2000**-1A*	34,600	26,300	18	13	32,000	25,900	35,000	9.2	20,000	3611074
	CHTF4860D6A*+TXV	MBVC2000**-1A*	35,000	26,600	18	13	32,400	26,200	35,000	9.2	20,000	3611075
	CSCF3642N6C*+TXV	MBE1600**-1B*	35,000	26,600	18	13	32,400	26,200	35,000	9.5	20,400	3610875
	CSCF3642N6C*+TXV	MBVC1600**-1A*	35,000	26,600	18	13	32,400	26,200	35,000	9.5	20,400	3611076
	CSCF3642N6C*+TXV	A*V80704B**	34,600	26,300	17.5	12.5	32,000	25,900	35,000	9.25	20,000	3610812
CSCF3642N6C*+TXV	A*V80905C**	34,600	26,300	17.5	12.5	32,000	25,900	35,000	9.25	20,000	3610813	
CSCF3642N6C*+TXV	A*V81155C**	34,600	26,300	17.5	12.5	32,000	25,900	35,000	9.25	20,000	3610814	
CSCF3642N6C*+TXV	A*V90453B**	34,600	26,300	17.5	12.5	32,000	25,900	35,000	9.25	20,000	3610815	

See Notes on Page 21.

# AHRI PERFORMANCE RATINGS (CONT.)

OUTDOOR UNIT	INDOOR UNITS		COOLING CAPACITY (BTU/H)				TVA RATINGS <sup>3</sup>		HEATING CAPACITY			AHRI #
	COILS & AIR HANDLERS	FURNACE/BLOWER	TOTAL	SENS.	SEER <sup>1</sup>	EER <sup>2</sup>	TOTAL	SENS.	HIGH	HSPF <sup>4</sup>	LOW	
ASZC18 0361A* (cont.)	CSCF3642N6C*+TXV	A*VC950453BXA*	34,600	26,300	17.5	12.5	32,000	25,900	35,000	9.25	20,000	3610816
	CSCF3642N6C*+TXV	A*V90905D**	35,000	26,600	18	13	32,400	26,200	35,000	9.25	20,400	3610877
	CSCF3642N6C*+TXV	A*V91155D**	35,000	26,600	18	13	32,400	26,200	35,000	9.25	20,400	3610878
	CSCF3642N6C*+TXV	A*VC90905DXA*	35,000	26,600	18	13	32,400	26,200	35,000	9.25	20,400	3610879
	CSCF3642N6C*+TXV	A*VC950905DXA*	35,000	26,600	18	13	32,400	26,200	35,000	9.25	20,400	3610880
	CSCF3642N6C*+TXV	A*VC951155DXA*	35,000	26,600	18	13	32,400	26,200	35,000	9.25	20,400	3610881
	CSCF3642N6C*+TXV	A*VC81155CXA*	34,600	26,300	17.5	12.5	32,000	25,900	35,000	9.25	20,000	3642838
	CSCF4860N6C*+TXV	A*V80704B**	34,600	26,300	17.5	12.5	32,000	25,900	35,000	9.25	20,000	3610817
	CSCF4860N6C*+TXV	A*V80905C**	34,600	26,300	17.5	12.5	32,000	25,900	35,000	9.25	20,000	3610818
	CSCF4860N6C*+TXV	A*V81155C**	34,600	26,300	17.5	12.5	32,000	25,900	35,000	9.25	20,000	3610819
	CSCF4860N6C*+TXV	A*V90453B**	34,600	26,300	17.5	12.5	32,000	25,900	35,000	9.25	20,000	3610820
	CSCF4860N6C*+TXV	A*V90704C**	34,600	26,300	17.5	12.5	32,000	25,900	35,000	9.25	20,000	3610821
	CSCF4860N6C*+TXV	A*VC90704CXA*	34,600	26,300	17.5	12.5	32,000	25,900	35,000	9.25	20,000	3610822
	CSCF4860N6C*+TXV	A*VC950453BXA*	34,600	26,300	17.5	12.5	32,000	25,900	35,000	9.25	20,000	3610823
	CSCF4860N6C*+TXV	A*VC950704CXA*	34,600	26,300	17.5	12.5	32,000	25,900	35,000	9.25	20,000	3610824
	CSCF4860N6C*+TXV	A*V90905D**	35,000	26,600	18	13	32,400	26,200	35,000	9.25	20,000	3610895
	CSCF4860N6C*+TXV	A*V91155D**	35,000	26,600	18	13	32,400	26,200	35,000	9.25	20,000	3610896
	CSCF4860N6C*+TXV	A*VC90905DXA*	35,000	26,600	18	13	32,400	26,200	35,000	9.25	20,000	3610897
	CSCF4860N6C*+TXV	A*VC950905DXA*	35,000	26,600	18	13	32,400	26,200	35,000	9.25	20,000	3610898
	CSCF4860N6C*+TXV	A*VC951155DXA*	35,000	26,600	18	13	32,400	26,200	35,000	9.25	20,000	3610899
	CSCF4860N6C*+TXV	A*VC81155CXA*	34,600	26,300	17.5	12.5	32,000	25,900	35,000	9.25	20,000	3642839
	CT*F3642*6A*+TXV	MBE1600**-1B*	34,600	26,300	18	13	32,000	25,900	35,000	9.5	20,400	3610826
	CT*F3642*6A*+TXV	MBVC1600**-1A*	34,600	26,300	18	13	32,000	25,900	35,000	9.5	20,400	3611077
	CT*F4860*6A*+TXV	MBE1600**-1B*	35,000	26,600	18	13	32,400	26,200	35,000	9.5	20,000	3610900
	CT*F4860*6A*+TXV	MBE2000**-1B*	35,000	26,600	18	13	32,400	26,200	35,000	9.25	20,000	3610902
	CT*F4860*6A*+TXV	MBVC1600**-1A*	35,000	26,600	18	13	32,400	26,200	35,000	9.5	20,000	3611078
	CT*F4860*6A*+TXV	MBVC2000**-1A*	35,000	26,600	18	13	32,400	26,200	35,000	9.25	20,000	3611079
	ASZC18 0481A*	AEPF426016C*+TXV		47,000	35,300	17.5	12.5	43,500	34,800	47,000	9.25	29,000
CA*F4961*6A*+TXV		MBE1600**-1B*	47,000	35,300	17.5	12.5	43,500	34,800	47,000	9.25	29,000	3610905
CA*F4961*6A*+TXV		MBE2000**-1B*	47,500	35,600	18	13	43,900	35,100	47,500	9.5	29,600	3610946
CA*F4961*6A*+TXV		MBVC1600**-1A*	47,000	35,300	17.5	12.5	43,500	34,800	47,000	9.25	29,000	3611080
CA*F4961*6A*+TXV		MBVC2000**-1A*	47,500	35,600	18	13	43,900	35,100	47,500	9.5	29,600	3611081
CA*F4961*6A*+TXV		A*V80905C**	47,000	35,300	17.5	12.5	43,500	34,800	47,000	9.25	29,000	3610907
CA*F4961*6A*+TXV		A*V81155C**	47,000	35,300	17.5	12.5	43,500	34,800	47,000	9.25	29,000	3610908
CA*F4961*6A*+TXV		A*V90704C**	47,000	35,300	17.5	12.5	43,500	34,800	47,000	9.25	29,000	3610909
CA*F4961*6A*+TXV		A*V90905D**	47,000	35,300	17.5	12.5	43,500	34,800	47,000	9.25	29,000	3610910
CA*F4961*6A*+TXV		A*V91155D**	47,000	35,300	17.75	12.5	43,500	34,800	47,000	9.25	29,000	3610911
CA*F4961*6A*+TXV		A*VC90704CXA*	47,000	35,300	17.5	12.5	43,500	34,800	47,000	9.25	29,000	3610912
CA*F4961*6A*+TXV		A*VC90905DXA*	47,000	35,300	17.5	12.5	43,500	34,800	47,000	9.25	29,000	3610913
CA*F4961*6A*+TXV		A*VC950704CXA*	47,000	35,300	17.5	12.5	43,500	34,800	47,000	9.25	29,000	3610914
CA*F4961*6A*+TXV		A*VC950905DXA*	47,000	35,300	17.5	12.5	43,500	34,800	47,000	9.25	29,000	3610915
CA*F4961*6A*+TXV		A*VC951155DXA*	47,000	35,300	17.75	12.5	43,500	34,800	47,000	9.25	29,000	3610916
CA*F4961*6A*+TXV		G*V950905D**	47,000	35,300	17.5	12.5	43,500	34,800	47,000	9.25	29,000	3610917
CA*F4961*6A*+TXV		G*V951155D**	47,000	35,300	17.75	12.5	43,500	34,800	47,000	9.25	29,000	3610918
CA*F4961*6A*+TXV		G*VC950905DXA*	47,000	35,300	17.5	12.5	43,500	34,800	47,000	9.25	29,000	3610919

See Notes on Page 21.



# AHRI PERFORMANCE RATINGS (CONT.)

OUTDOOR UNIT	INDOOR UNITS		COOLING CAPACITY (BTU/H)				TVA RATINGS <sup>3</sup>		HEATING CAPACITY			AHRI #
	COILS & AIR HANDLERS	FURNACE/BLOWER	TOTAL	SENS.	SEER <sup>1</sup>	EER <sup>2</sup>	TOTAL	SENS.	HIGH	HSPF <sup>4</sup>	LOW	
ASZC18 0481A* (cont.)	CA*F4961*6A*+TXV	G*VC951155DXA*	47,000	35,300	17.75	12.5	43,500	34,800	47,000	9.25	29,000	3610920
	CA*F4961*6A*+TXV	A*VC80905CXA*	47,000	35,300	17	12.2	43,500	34,800	47,000	9.25	29,000	3642884
	CHPF4860D6D*+TXV	MBE2000**-1B*	47,500	35,600	18	13	43,900	35,100	47,500	9.5	29,600	3610961
	CHPF4860D6D*+TXV	MBVC2000**-1A*	47,500	35,600	18	13	43,900	35,100	47,500	9.5	29,600	3611082
	CHPF4860D6D*+TXV	A*V80905C**	47,000	35,300	17.5	12.5	43,500	34,800	47,000	9.25	29,000	3610921
	CHPF4860D6D*+TXV	A*V81155C**	47,000	35,300	17.5	12.5	43,500	34,800	47,000	9.25	29,000	3610922
	CHPF4860D6D*+TXV	A*V90704C**	47,000	35,300	17.5	12.5	43,500	34,800	47,000	9.25	29,000	3610923
	CHPF4860D6D*+TXV	A*V90905D**	47,000	35,300	17.5	12.5	43,500	34,800	47,000	9.25	29,000	3610924
	CHPF4860D6D*+TXV	A*V91155D**	47,000	35,300	17.75	12.5	43,500	34,800	47,000	9.25	29,000	3610925
	CHPF4860D6D*+TXV	A*VC90704CXA*	47,000	35,300	17.5	12.5	43,500	34,800	47,000	9.25	29,000	3610926
	CHPF4860D6D*+TXV	A*VC90905DXA*	47,000	35,300	17.5	12.5	43,500	34,800	47,000	9.25	29,000	3610927
	CHPF4860D6D*+TXV	A*VC950704CXA*	47,000	35,300	17.5	12.5	43,500	34,800	47,000	9.25	29,000	3610928
	CHPF4860D6D*+TXV	A*VC950905DXA*	47,000	35,300	17.5	12.5	43,500	34,800	47,000	9.25	29,000	3610929
	CHPF4860D6D*+TXV	A*VC951155DXA*	47,000	35,300	17.75	12.5	43,500	34,800	47,000	9.25	29,000	3610930
	CHPF4860D6D*+TXV	A*VC80905CXA*	47,000	35,300	17	12.2	43,500	34,800	47,000	9.25	29,000	3642885
	CHTF4860D6A*+TXV	MBVC2000**-1A*	47,000	35,300	18	13	43,500	34,800	47,500	9.5	29,600	3611083
	CSCF4860N6C*+TXV	MBE2000**-1B*	47,500	35,600	18	13	43,900	35,100	47,500	9.5	29,600	3610972
	CSCF4860N6C*+TXV	MBVC2000**-1A*	47,500	35,600	18	13	43,900	35,100	47,500	9.5	29,600	3611084
	CSCF4860N6C*+TXV	A*V80905C**	47,000	35,300	17.5	12.5	43,500	34,800	47,000	9.25	29,000	3610933
	CSCF4860N6C*+TXV	A*V81155C**	47,000	35,300	17.5	12.5	43,500	34,800	47,000	9.25	29,000	3610934
	CSCF4860N6C*+TXV	A*V90704C**	47,000	35,300	17.5	12.5	43,500	34,800	47,000	9.25	29,000	3610935
	CSCF4860N6C*+TXV	A*V90905D**	47,000	35,300	17.5	12.5	43,500	34,800	47,000	9.25	29,000	3610936
	CSCF4860N6C*+TXV	A*V91155D**	47,000	35,300	17.75	12.5	43,500	34,800	47,000	9.25	29,000	3610937
	CSCF4860N6C*+TXV	A*VC90704CXA*	47,000	35,300	17.5	12.5	43,500	34,800	47,000	9.25	29,000	3610938
	CSCF4860N6C*+TXV	A*VC90905DXA*	47,000	35,300	17.5	12.5	43,500	34,800	47,000	9.25	29,000	3610939
	CSCF4860N6C*+TXV	A*VC950704CXA*	47,000	35,300	17.5	12.5	43,500	34,800	47,000	9.25	29,000	3610940
	CSCF4860N6C*+TXV	A*VC950905DXA*	47,000	35,300	17.5	12.5	43,500	34,800	47,000	9.25	29,000	3610941
	CSCF4860N6C*+TXV	A*VC951155DXA*	47,000	35,300	17.75	12.5	43,500	34,800	47,000	9.25	29,000	3610942
	CSCF4860N6C*+TXV	A*VC80905CXA*	47,000	35,300	17	12.2	43,500	34,800	47,000	9.25	29,000	3642886
	CT*F4860*6A*+TXV	MBE1600**-1B*	47,000	35,300	17.5	12.5	43,500	34,800	47,000	9.25	29,000	3610943
CT*F4860*6A*+TXV	MBE2000**-1B*	47,000	35,300	18	13	43,500	34,800	47,500	9.5	29,600	3610944	
CT*F4860*6A*+TXV	MBVC1600**-1A*	47,000	35,300	17.5	12.5	43,500	34,800	47,000	9.25	29,000	3611085	
CT*F4860*6A*+TXV	MBVC2000**-1A*	47,000	35,300	18	13	43,500	34,800	47,500	9.5	29,600	3611086	
ASZC18 0601A*	AEPF426016C*+TXV		56,000	40,300	16	12.5	51,800	39,900	56,000	9	35,000	3610982
	CA*F4961*6A*+TXV	MBE2000**-1B*	57,000	41,000	17	12.5	52,700	40,600	57,000	9.5	36,400	3610985
	CA*F4961*6A*+TXV	MBVC2000**-1A*	57,000	41,000	17	12.5	52,700	40,600	57,000	9.5	36,400	3611087
	CA*F4961*6A*+TXV	A*V80905C**	57,000	41,000	16	12	52,700	40,600	57,000	9.25	35,000	3610997
	CA*F4961*6A*+TXV	A*V81155C**	57,000	41,000	16	12	52,700	40,600	57,000	9.25	35,000	3610998
	CA*F4961*6A*+TXV	A*V90905D**	57,000	41,000	16	12	52,700	40,600	57,000	9.25	35,000	3610999
	CA*F4961*6A*+TXV	A*V91155D**	57,000	41,000	16	12	52,700	40,600	57,000	9.25	35,000	3611000
	CA*F4961*6A*+TXV	A*VC90905DXA*	57,000	41,000	16	12	52,700	40,600	57,000	9.25	35,000	3611001
	CA*F4961*6A*+TXV	A*VC950905DXA*	57,000	41,000	16	12	52,700	40,600	57,000	9.25	35,000	3611002
	CA*F4961*6A*+TXV	A*VC951155DXA*	57,000	41,000	16	12	52,700	40,600	57,000	9.25	35,000	3611003
	CA*F4961*6A*+TXV	G*V950905D**	57,000	41,000	16	12	52,700	40,600	57,000	9.25	35,000	3611004
	CA*F4961*6A*+TXV	G*V951155D**	57,000	41,000	16	12	52,700	40,600	57,000	9.25	35,000	3611005

See Notes on Page 21.

# AHRI PERFORMANCE RATINGS (CONT.)

OUTDOOR UNIT	INDOOR UNITS		COOLING CAPACITY (BTU/H)				TVA RATINGS <sup>3</sup>		HEATING CAPACITY			AHRI #
	COILS & AIR HANDLERS	FURNACE/BLOWER	TOTAL	SENS.	SEER <sup>1</sup>	EER <sup>2</sup>	TOTAL	SENS.	HIGH	HSPF <sup>4</sup>	LOW	
ASZC18 0601A* (cont.)	CA*F4961*6A*+TXV	G*VC950905DXA*	57,000	41,000	16	12	52,700	40,600	57,000	9.25	35,000	3611006
	CA*F4961*6A*+TXV	G*VC951155DXA*	57,000	41,000	16	12	52,700	40,600	57,000	9.25	35,000	3611007
	CA*F4961*6A*+TXV	A*VC80905CXA*	57,000	41,000	15.5	11.5	52,700	40,600	57,000	9.25	35,000	3642911
	CA*F4961*6A*+TXV	A*VC81155CXA*	57,000	41,000	15.5	11.5	52,700	40,600	57,000	9.25	35,000	3642914
	CHPF4860D6D*+TXV	MBE2000**-1B*	57,000	41,000	17	12.5	52,700	40,600	57,000	9.5	36,400	3611009
	CHPF4860D6D*+TXV	MBVC2000**-1A*	57,000	41,000	17	12.5	52,700	40,600	57,000	9.5	36,400	3611088
	CHPF4860D6D*+TXV	A*V80905C**	57,000	41,000	16	12	52,700	40,600	57,000	9.25	35,000	3611017
	CHPF4860D6D*+TXV	A*V81155C**	57,000	41,000	16	12	52,700	40,600	57,000	9.25	35,000	3611018
	CHPF4860D6D*+TXV	A*V90905D**	57,000	41,000	16	12	52,700	40,600	57,000	9.25	35,000	3611019
	CHPF4860D6D*+TXV	A*V91155D**	57,000	41,000	16	12	52,700	40,600	57,000	9.25	35,000	3611020
	CHPF4860D6D*+TXV	A*VC90905DXA*	57,000	41,000	16	12	52,700	40,600	57,000	9.25	35,000	3611021
	CHPF4860D6D*+TXV	A*VC950905DXA*	57,000	41,000	16	12	52,700	40,600	57,000	9.25	35,000	3611022
	CHPF4860D6D*+TXV	A*VC951155DXA*	57,000	41,000	16	12	52,700	40,600	57,000	9.25	35,000	3611023
	CHPF4860D6D*+TXV	A*VC80905CXA*	57,000	41,000	15.5	11.5	52,700	40,600	57,000	9.25	35,000	3642912
	CHPF4860D6D*+TXV	A*VC81155CXA*	57,000	41,000	15.5	11.5	52,700	40,600	57,000	9.25	35,000	3642915
	CHTF4860D6A*+TXV	MBVC2000**-1A*	57,000	41,000	17	12.5	52,700	40,600	57,000	9.5	36,400	3611089
	CSCF4860N6C*+TXV	MBE2000**-1B*	57,000	41,000	17	12.5	52,700	40,600	57,000	9.5	36,400	3611024
	CSCF4860N6C*+TXV	MBVC2000**-1A*	57,000	41,000	17	12.5	52,700	40,600	57,000	9.5	36,400	3611090
	CSCF4860N6C*+TXV	A*V80905C**	57,000	41,000	16	12	52,700	40,600	57,000	9.25	35,000	3611032
	CSCF4860N6C*+TXV	A*V81155C**	57,000	41,000	16	12	52,700	40,600	57,000	9.25	35,000	3611033
	CSCF4860N6C*+TXV	A*V90905D**	57,000	41,000	16	12	52,700	40,600	57,000	9.25	35,000	3611034
	CSCF4860N6C*+TXV	A*V91155D**	57,000	41,000	16	12	52,700	40,600	57,000	9.25	35,000	3611035
	CSCF4860N6C*+TXV	A*VC90905DXA*	57,000	41,000	16	12	52,700	40,600	57,000	9.25	35,000	3611036
	CSCF4860N6C*+TXV	A*VC950905DXA*	57,000	41,000	16	12	52,700	40,600	57,000	9.25	35,000	3611037
	CSCF4860N6C*+TXV	A*VC951155DXA*	57,000	41,000	16	12	52,700	40,600	57,000	9.25	35,000	3611038
	CSCF4860N6C*+TXV	A*VC80905CXA*	57,000	41,000	15.5	11.5	52,700	40,600	57,000	9.25	35,000	3642913
	CSCF4860N6C*+TXV	A*VC81155CXA*	57,000	41,000	15.5	11.5	52,700	40,600	57,000	9.25	35,000	3642916
	CT*F4860*6A*+TXV	MBE2000**-1B*	57,000	41,000	17	12.5	52,700	40,600	57,000	9.5	36,400	3611040
	CT*F4860*6A*+TXV	MBVC2000**-1A*	57,000	41,000	17	12.5	52,700	40,600	57,000	9.5	36,400	3611091

<sup>1</sup> Seasonal Energy Efficiency Ratio; Certified per AHRI 210/240 @ 80°F/ 67°F/ 95°F

<sup>3</sup> TVA Rating: BTU/h @ 75°F/ 63°F - 95°F

<sup>2</sup> Energy Efficiency Ratio @ 80°F/ 67°F/ 95°F

<sup>4</sup> HSPF = Heating Seasonal Performance Factor

**NOTES:**

- Always check the S&R plate for electrical data on the unit being installed.
- When matching the outdoor unit to the indoor unit, use the piston supplied with the outdoor unit or that specified on the piston kit chart supplied with the indoor unit.
- EEP - Order from Service Dept. Part No. B13707-38 or new Solid State Board B13707-35S. Part No. B13707-38 is not interchangeable with B13707-35S. The Goodman Gas Furnace contains the EEP cooling time delay

# ASZC18 WIRING DIAGRAM

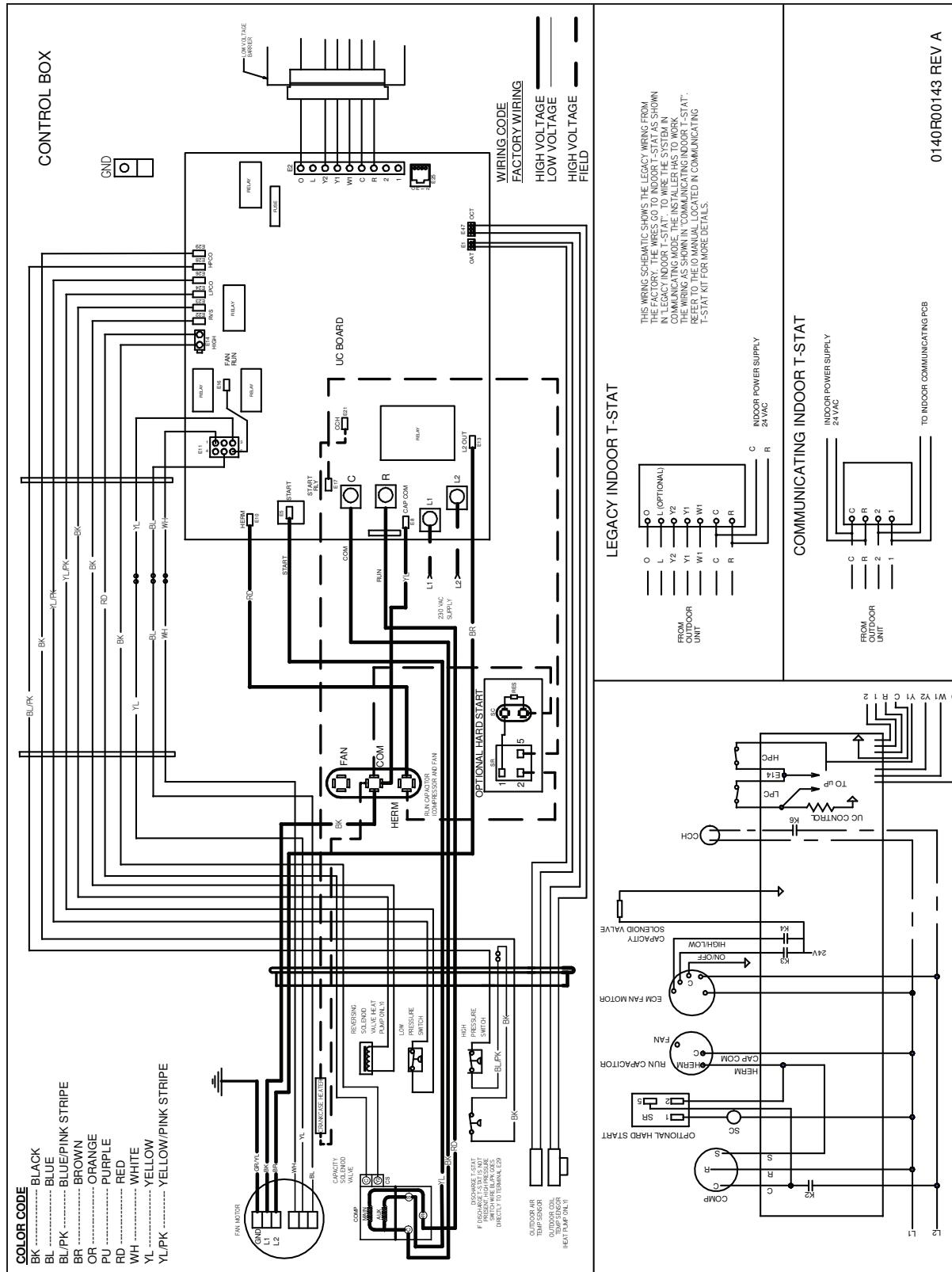

THIS WIRING SCHEMATIC SHOWS THE LEGACY WIRING FROM THE FACTORY FOR THE AS SHOWN IN THE LEGACY INDOOR T-STAT TO AN INDOOR COMMUNICATING MODE. THE INSTALLER HAS TO WORK THE WIRING AS SHOWN IN 'COMMUNICATING INDOOR T-STAT'. REFER TO THE IO MANUAL LOCATED IN COMMUNICATING T-STAT KIT FOR MORE DETAILS.



**High Voltage:** Disconnect all power before servicing or installing this unit. Multiple power sources may be present. Failure to do so may cause property damage, personal injury, or death.

**WARNING**

Wiring is subject to change. Always refer to the wiring diagram on the unit for the most up-to-date wiring

0140R00143 REV A

## DIMENSIONS

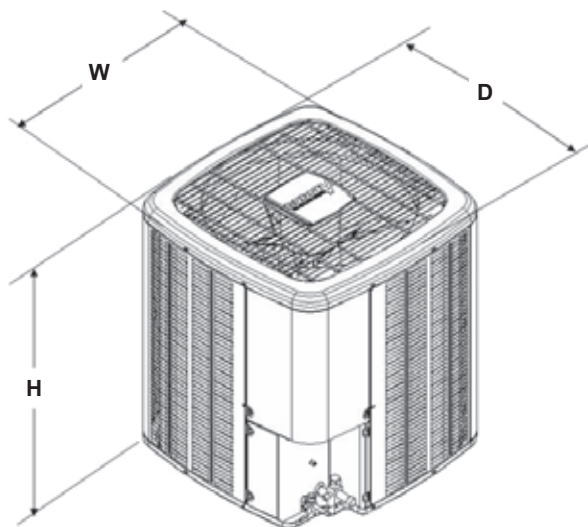

MODEL	W"	D"	H"
ASZC180361A	35½	35½	38¼
ASZC180481A	35½	35½	38¼
ASZC180601A	35½	35½	38¼

## ACCESSORIES

MODEL	DESCRIPTION	ASZC18 036	ASZC18 048	ASZC18 060
ABK-20	Anchor Bracket Kit ▼			
B1141643 <sup>1</sup>	24V Transformer	X	X	X
CSR-U-1	Hard-start Kit	X		
CSR-U-2	Hard-start Kit	X	X	X
CSR-U-3	Hard-start Kit		X	X
FSK01A <sup>2</sup>	Freeze Protection Kit	X	X	X
OT18-60A <sup>3</sup>	Outdoor Thermostat/Lockout Thermostat	X	X	X
TX2N4 <sup>4</sup>	TXV Kit			
TX3N4 <sup>4</sup>	TXV Kit	X		
TX5N4 <sup>4</sup>	TXV Kit		X	X

▼ Contains 20 brackets; four brackets needed to anchor unit to pad

<sup>1</sup> Available in 24V legacy mode only. This feature is integrated in the communicating mode.

<sup>2</sup> Installed on indoor coil

<sup>3</sup> Available in 24V legacy mode only. This feature is integrated in the communicating mode. Required for heat pump applications where ambient temperature falls below 0 0F with 50% or higher relative humidity.

<sup>4</sup> Field-installed, non-bleed, expansion valve kit; Condensing units and heat pumps with reciprocating compressors require the use of start-assist components when used in conjunction with an indoor coil using a non-bleed thermal expansion valve refrigerant metering device.

