

# Distinctions™

Heating & Air Conditioning  
**Amana**

## PRODUCT SPECIFICATIONS



**80% AFUE**

**HEATING INPUT:  
45,000–140,000 BTU/h**



\* Complete warranty details available from your local dealer or at [www.amana-hac.com](http://www.amana-hac.com). To receive the Lifetime Heat Exchanger Limited Warranty (good for as long as you own your home) and 10-Year Parts Limited Warranty, online registration must be completed within 60 days of installation. Online registration is not required in California or Québec.

## GMS8/GDS8/GHS8 MULTI-POSITION, SINGLE-STAGE MULTI-SPEED GAS FURNACES

The Amana® Distinctions™ brand GMS8/GDS8/GHS8 Single-Stage, Multi-Speed Gas Furnaces feature a patented aluminized-steel tubular heat exchanger and energy-efficient Hot Surface Ignition system. This furnace is run-tested for heating or combination heating/cooling applications. With a heavy-gauge, reinforced steel cabinet and durable baked enamel finish, this unit can be installed in a variety of locations.

### Standard Features

- Patented dual-diameter tubular heat exchanger
- Single-stage combination redundant gas valve
- Norton hot surface mini-igniter
- Quiet multi-speed direct-drive circulator blower motor
- Furnace control board with self-diagnostics and low-voltage terminal block
- Quiet single-speed, induced-draft blower

### Cabinet Features

- Foil-faced insulation lines the heat exchanger compartment
- Factory-sealed to achieve 2% or less leakage rate at 1.0" water gauge external duct static pressure
- Designed for multi-position installation:  
GMS8 and GHS8 — upflow, horizontal left or right  
GDS8 — dedicated downflow
- Coil and furnace fit flush for most installations

### Contents

Nomenclature .....	2
Product Specifications .....	3
Dimensions .....	5
Airflow Data .....	8
Wiring Diagrams .....	11
Accessories .....	12

NOMENCLATURE

	G	M	S	8	045	4	B	X	A	
	1	2	3	4,5	6,7,8	9	10	11	12	
<b>Brand</b>	G Goodman® Brand or Distinctions™								<b>Revisions</b>	A Initial Release B 1st Revision C 2nd Revision
<b>Airflow Direction</b>	C Downflow/Horizontal D Dedicated Downflow H High Airflow K Dedicated Upflow M Upflow/Horizontal								<b>NOx</b>	N Natural Gas X Low NOx
<b>Description/Motor</b>	V Two-Stage/Variable-speed H Two-Stage/Multi-speed S Single-Stage/Multi-speed E Two-Stage/High-Efficiency								<b>Cabinet Width</b>	A 14" B 17½" C 21" D 24½"
<b>AFUE</b>	95 95% 9 93%+ 8 80%								<b>Maximum CFM @ 0.5" ESP</b>	3 1200 5 2000 4 1600
									<b>MBTU/h</b>	045: 45,000 115: 115,000 070: 70,000 140: 140,000 090: 90,000

# GMS8 SPECIFICATIONS

	GMS8 0453AN*	GMS8 0703AN*	GMS8 0704BN*	GMS8 0904BN*	GMS8 0905CN*	GMS8 1155CN*	GMS8 1405DN
<b>HEATING CAPACITY</b>							
Input <sup>1</sup>	45,000	70,000	70,000	90,000	90,000	115,000	140,000
Natural Gas Output <sup>1</sup>	36,000	56,000	56,000	72,000	72,000	92,000	112,000
LP Gas Output <sup>1</sup>	32,000	48,000	48,000	64,000	64,000	80,000	96,000
AFUE <sup>2</sup>	80	80	80	80	80	80	80
Tons AC @ 0.5" ESP	3	3	4	4	5	5	5
<b>CIRCULATOR BLOWER</b>							
Size (D x W)	10" x 6"	10" x 6"	10" x 8"	10" x 8"	10" x 10"	10" x 10"	11" x 10"
Horsepower @1075 RPM	⅓	⅓	½	½	½	½	¾
Speed	4	4	4	4	4	4	4
Vent Diameter <sup>3</sup>	4"	4"	4"	4"	4"	4"	4"
No. of Burners	2	3	3	4	4	5	6
Disposable Filter Size (in <sup>2</sup> )	580	580	770	770	960	960	960
<b>ELECTRICAL DATA</b>							
Min. Circuit Ampacity <sup>4</sup>	8.1	8.1	12.5	12.5	12.5	12.5	14.7
Max. Overcurrent Device (amps) <sup>5</sup>	15	15	15	15	15	15	15
<b>SHIP WEIGHT (LBS)</b>							
	120	130	143	153	163	163	173

\* California NOx compliant

<sup>1</sup> Natural Gas BTU/h. For altitudes above 2,000', reduce input rating 4% for each 1,000' above sea level.

<sup>2</sup> DOE AFUE based upon Isolated Combustion System (ICS)

<sup>3</sup> Vent diameters may vary depending upon vent length. Refer to the latest editions of the National Fuel Gas Code NFPA 54/ANSI Z223.1 (in the USA) and the Canada National Standard of Canada, CAN/CSA B149.1 and CAN/CSA B142.2 (in Canada).

<sup>4</sup> Minimum Circuit Ampacity = (1.25 x Circulator Blower Amps) + ID Blower amps. Wire size should be determined in accordance with National Electrical Codes. Extensive wire runs will require larger wire sizes.

<sup>5</sup> Maximum Overcurrent Protection Device refers to maximum recommended fuse or circuit breaker size. May use fuses or HACR-type circuit breakers of the same size as noted.

**NOTES:**

- All furnaces are manufactured for use on 115 VAC, 60 Hz, single-phase electrical supply.
- Gas Service Connection ½" FPT
- Important: Size fuses and wires properly; make electrical connections in accordance with National Electrical Code and/or all existing local codes.

# GDS8/GHS8 SPECIFICATIONS

	<b>GDS8 0453AX</b>	<b>GDS8 0703AX</b>	<b>GDS8 0904BX</b>	<b>GDS8 1155CX</b>	<b>GHS8 0453AX</b>	<b>GHS8 0704BX</b>	<b>GHS8 0905CX</b>
<b>HEATING CAPACITY</b>							
Input <sup>1</sup>	45,000	70,000	90,000	115,000	45,000	70,000	90,000
Natural Gas Output <sup>1</sup>	36,000	56,000	72,000	92,000	36,000	56,000	72,000
LP Gas Output <sup>1</sup>	32,000	48,000	64,000	80,000	32,000	48,000	64,000
AFUE <sup>2</sup>	80	80	80	80	80	80	80
Temperature Rise Range (°F)	35-65	30-60	35-65	40 - 70	15 - 45	30-60	35 - 65
Tons AC @ 0.5" ESP	3	3	4	5	3	4	5
<b>CIRCULATOR BLOWER</b>							
Size (D x W)	10" x 6"	10" x 6"	10" x 8"	10" x 10"	11" x 6"	11" x 8"	11" x 10"
Horsepower @ 1750 RPM	1/3	1/3	1/2	3/4	1/2	3/4	3/4
Speed	4	4	4	4	4	4	4
Vent Diameter <sup>3</sup>	4"	4"	4"	4"	4"	4"	4"
No. of Burners	2	3	4	5	2	3	4
Disposable Filter Size (in <sup>2</sup> )	580	580	770	960	580	770	960
<b>ELECTRICAL DATA</b>							
Min. Circuit Ampacity <sup>4</sup>	8.5	8.5	10.5	10.5	10.5	13.7	13.7
Max. Overcurrent Device (amps) <sup>5</sup>	15	15	15	15	15	15	15
<b>SHIP WEIGHT (LBS)</b>	120	130	153	175	120	130	153

<sup>1</sup> Natural Gas BTU/h. For altitudes above 2,000', reduce input rating 4% for each 1,000' above sea level.

<sup>2</sup> DOE AFUE based upon Isolated Combustion System (ICS)

<sup>3</sup> Vent diameters may vary depending upon vent length. Refer to the latest editions of the National Fuel Gas Code NFPA 54/ANSI Z223.1 (in the USA) and the Canada National Standard of Canada, CAN/CSA B149.1 and CAN/CSA B142.2 (in Canada).

<sup>4</sup> Minimum Circuit Ampacity = (1.25 x Circulator Blower Amps) + ID Blower amps. Wire size should be determined in accordance with National Electrical Codes. Extensive wire runs will require larger wire sizes.

<sup>5</sup> Maximum Overcurrent Protection Device refers to maximum recommended fuse or circuit breaker size. May use fuses or HACR-type circuit breakers of the same size as noted.

**NOTES:**

- All furnaces are manufactured for use on 115 VAC, 60 Hz, single-phase electrical supply.
- Gas Service Connection ½" FPT
- Important: Size fuses and wires properly and make electrical connections in accordance with the National Electrical Code and/or all existing local codes.

# GMS8 DIMENSIONS

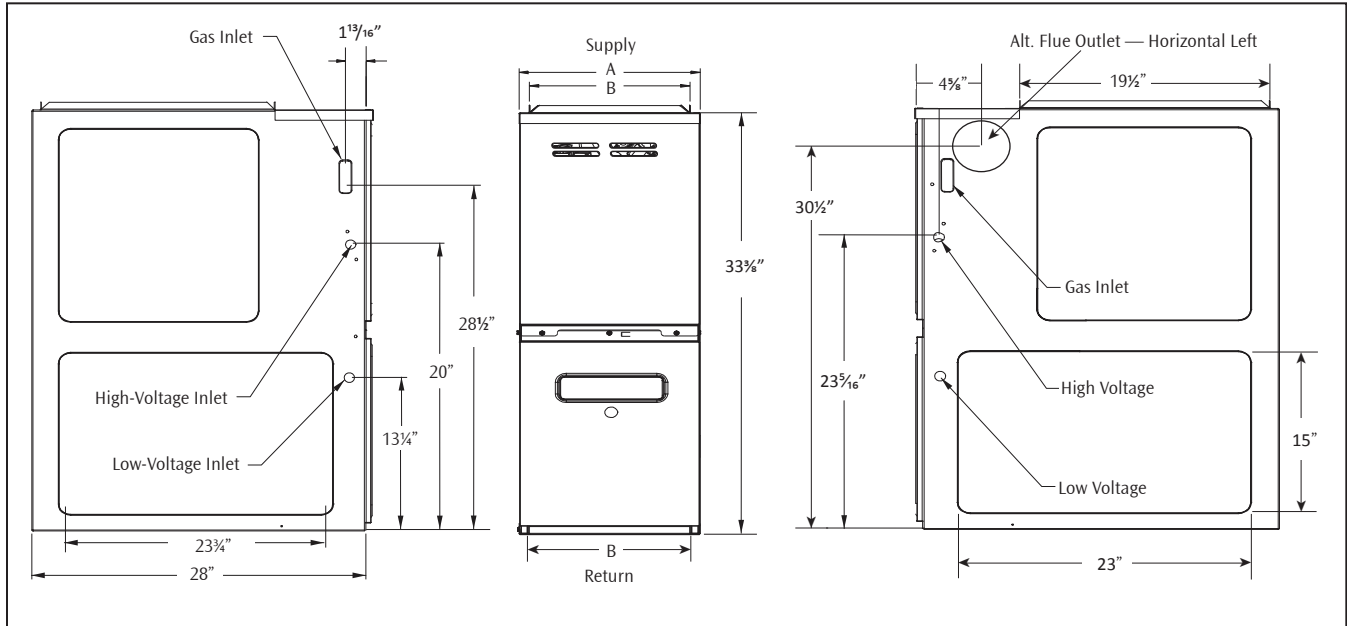

MODEL	A	B
GMS80453AN*	14"	12 1/2"
GMS80703AN*	14"	12 1/2"
GMS80704BN*	17 1/2"	16"
GMS80904BN*	17 1/2"	16"
GMS80905CN*	21"	19 1/2"
GMS81155CN*	21"	19 1/2"
GMS81405DN*	24 1/2"	23"

**NOTES**

- Line voltage wiring can enter through the right or left side of furnace. Low-voltage wiring can enter through the right or left side of furnace.
- Conversion kits for high-altitude (7,000+ ft) natural gas operation are available. Contact your Goodman distributor or dealer for details.

## MINIMUM CLEARANCES TO COMBUSTIBLE MATERIALS

SIDES	REAR	FRONT <sup>1</sup>	VENT <sup>2</sup>		TOP
			SW	B	
1"	0"	3"	6"	1"	1"

<sup>1</sup> 24" clearance for serviceability recommended.

<sup>2</sup> Single Wall Vent (SW) to be used only as a connector. Refer to the latest editions of the National Fuel Gas Code NFPA 54/ ANSI Z223.1 (in the USA) and the Canada National Standard of Canada, CAN/CSA B149.1 and CAN/CSA B142.2 (in Canada).

**Note:** GMS8 approved for line contact in the horizontal position.

# GDS8 DIMENSIONS

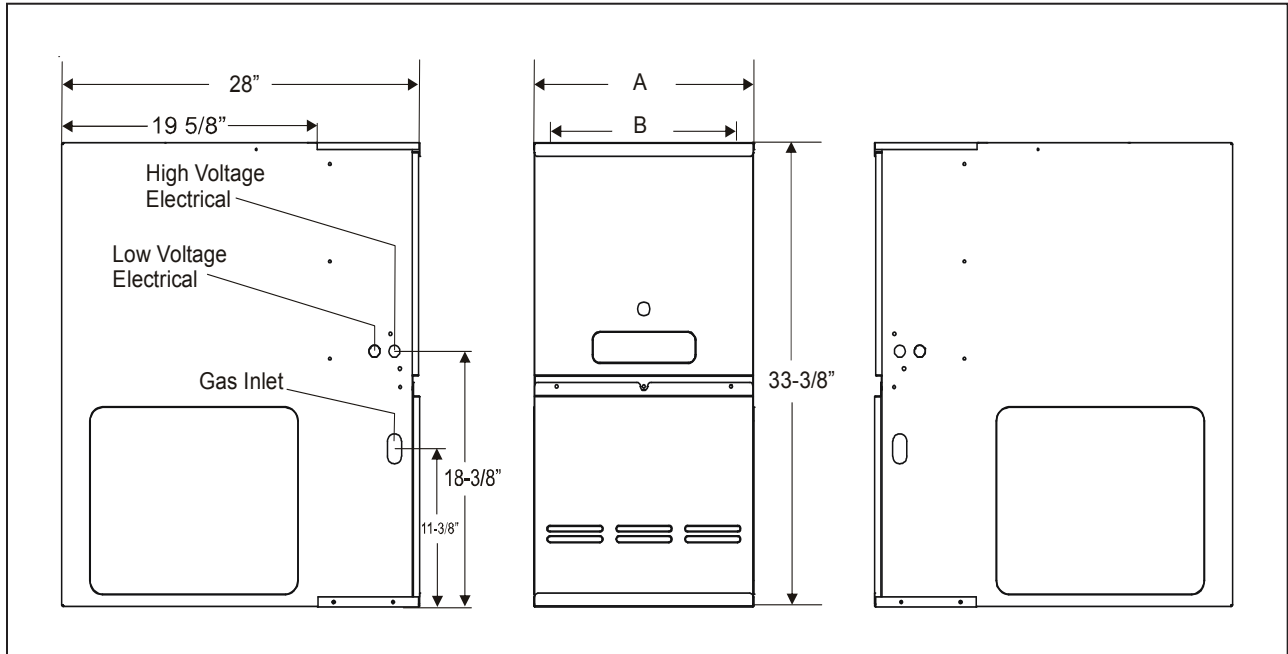

MODEL	A	B	NON-COMBUSTIBLE FLOOR BASE
GDS80453AX	14"	12½"	SBT14
GDS80703AX	14"	12½"	SBT14
GDS80904BX	17½"	16"	SBT17
GDS81155CX	21"	19½"	SBT21

**NOTES**

- Line voltage wiring can enter through the right or left side of furnace. Low-voltage wiring can enter through the right or left side of furnace.
- Conversion kits for high-altitude (7,000+ ft) natural gas operation are available. Contact your Goodman distributor or dealer for details.

## MINIMUM CLEARANCES TO COMBUSTIBLE MATERIALS

SIDES	REAR	FRONT <sup>1</sup>	VENT <sup>2</sup>		TOP
			SW	B	
1"	0"	3"	6"	1"	1"

<sup>1</sup> 24" clearance for serviceability recommended.

<sup>2</sup> Single Wall Vent (SW) to be used only as a connector. Refer to the latest editions of the National Fuel Gas Code NFPA 54/ ANSI Z223.1 (in the USA) and the Canada National Standard of Canada, CAN/CSA B149.1 and CAN/CSA B142.2 (in Canada).

# GHS8 DIMENSIONS

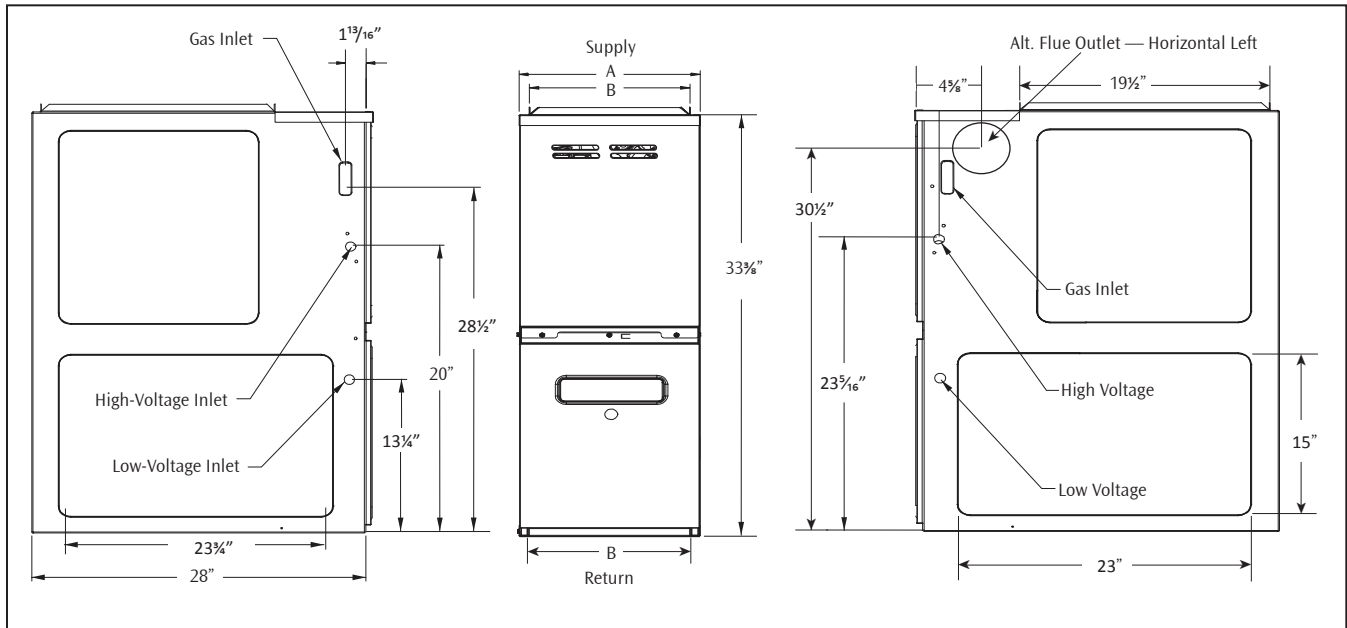

MODEL	A	B
GHS80453AX	14"	12 1/2"
GHS80704BX	17 1/2"	16"
GHS80905CX	21"	19 1/2"

**NOTES**

- Line voltage wiring can enter through the right or left side of furnace.
- Low-voltage wiring can enter through the right or left side of furnace.
- Conversion kits for high-altitude (7,000+ ft) natural gas operation are available. Contact your Goodman distributor or dealer for details.

## MINIMUM CLEARANCES TO COMBUSTIBLE MATERIALS

SIDES	REAR	FRONT <sup>1</sup>	VENT <sup>2</sup>		TOP
			SW	B	
1"	0"	3"	6"	1"	1"

<sup>1</sup> 24" clearance for serviceability recommended.

<sup>2</sup> Single Wall Vent (SW) to be used only as a connector. Refer to the latest editions of the National Fuel Gas Code NFPA 54/ ANSI Z223.1 (in the USA) and the Canada National Standard of Canada, CAN/CSA B149.1 and CAN/CSA B142.2 (in Canada).

Note: GHS8 models approved for line contact in the horizontal position.

# GMS8 AIRFLOW DATA

CFM & TEMPERATURE RISE VS. EXTERNAL STATIC PRESSURE															
MODEL	MOTOR SPEED	TONS AC <sup>1</sup>	EXTERNAL STATIC PRESSURE, (INCHES WATER COLUMN)												
			0.1		0.2		0.3		0.4		0.5		0.6	0.7	0.8
			CFM	RISE	CFM	RISE	CFM	RISE	CFM	RISE	CFM	RISE	CFM	CFM	CFM
GMS8 0453A	High	3	1,521	22	1,466	23	1,414	24	1,373	24	1,298	26	1,243	1,164	1,075
	Med	2.5	1,160	29	1,160	29	1,132	29	1,121	30	1,082	31	1,042	997	925
	Med-Lo	2	961	35	955	35	948	35	932	36	913	37	882	821	803
	Low	1.5	781	43	785	42	781	43	773	43	761	44	745	716	668
GMS8 0703A	High	3	1,422	36	1,352	38	1,307	40	1,197	43	1,157	45	1,092	1,075	983
	Med	2.5	1,098	47	1,081	48	1,051	49	1,039	50	1,021	51	983	924	868
	Med-Lo	2	919	56	913	57	892	58	847	----	829	----	818	792	728
	Low	1.5	758	----	741	----	741	----	733	----	699	----	677	649	626
GMS8 0704B	High	4	2,134	----	2,100	25	2,042	25	1,975	26	1,883	28	1,786	1,700	1,601
	Med	3.5	1,668	31	1,663	31	1,656	31	1,645	32	1,616	32	1,549	1,492	1,391
	Med-Lo	3	1,419	37	1,426	36	1,426	36	1,432	36	1,419	37	1,378	1,328	1,261
	Low	2.5	1,134	46	1,145	45	1,166	44	1,171	44	1,160	45	1,144	1111	1071
GMS8 0904B	High	4	2,051	----	1,983	----	1,895	35	1,812	37	1,725	39	1,627	1,530	1,439
	Med	3.5	1,736	38	1,708	39	1,652	40	1,611	41	1,540	43	1,475	1,394	1,307
	Med-Lo	3	1,493	45	1,668	40	1,459	46	1,429	47	1,389	48	1,339	1,274	1,204
	Low	2.5	1,200	56	1,185	56	1,180	56	1,173	57	1,158	58	1,125	1,125	1080
GMS8 0905C	High	5	2,290	----	2,229	----	2,155	----	2,047	----	1,960	----	1,837	1,712	1,584
	Med	4	1,852	36	1,820	37	1,777	38	1,719	39	1,641	41	1,567	1,469	1,382
	Med-Lo	3.5	1,615	41	1,592	42	1,556	43	1,516	44	1,470	45	1,405	1,346	1,235
	Low	3	1,290	52	1,285	52	1,265	53	1,235	54	1,214	55	1,174	1044	904
GMS8 1155C	High	5	2,323	37	2,225	38	2,120	40	2,040	42	1,974	43	1,801	1,688	1,577
	Med	4	1,858	46	1,847	46	1,799	47	1,744	49	1,674	51	1,577	1,493	1,399
	Med-Lo	3.5	1,596	53	1,587	54	1,571	54	1,552	55	1,493	57	1,397	1,326	1,217
	Low	3	1,291	----	1,272	----	1,261	----	1,257	----	1,205	----	1,168	1118	1060
GMS8 1405D	High	5	2,469	42	2,389	43	2,300	45	2,223	47	2,131	49	2,027	1,902	1,786
	Med	4	1,575	66	1,558	67	1,545	67	1,513	69	1,500	69	1,419	1,354	1,271
	Med-Lo	3.5	1,402	----	1,380	----	1,343	----	1,319	----	1,296	----	1,245	1,183	1,106
	Low	3	1,200	----	1,186	----	1,161	----	1,127	----	1,082	----	1,042	995	926

**Notes:**

- CFM in chart is without filter(s). Filters do not ship with this furnace, but must be provided by the installer. If the furnace requires two return filters, this chart assumes both filters are installed.
- All furnaces ship as high-speed cooling and medium-speed heating. Installer must adjust blower cooling and heating speed as needed.
- For most jobs, about 400 CFM per ton when cooling is desirable.
- INSTALLATION IS TO BE ADJUSTED TO OBTAIN TEMPERATURE RISE WITHIN THE RANGE SPECIFIED ON THE RATING PLATE.
- This chart is for information only. For satisfactory operation, external static pressure must not exceed value shown on the rating plate.
- The dashed (----) areas indicate a temperature rise not recommended for this model.
- The above chart is for U.S. furnaces installed at 0-2000 feet. At higher altitudes, a properly derated unit will have approximately the same temperature rise at a particular CFM, while ESP at the CFM will be lower.



# AIRFLOW DATA — GDS8 / GHS8

## GDS8

(CFM & TEMPERATURE RISE VS. EXTERNAL STATIC PRESSURE)															
MODEL	MOTOR SPEED	TONS AC <sup>1</sup>	EXTERNAL STATIC PRESSURE, (INCHES WATER COLUMN)												
			0.1		0.2		0.3		0.4		0.5		0.6	0.7	0.8
			CFM	RISE	CFM	RISE	CFM	RISE	CFM	RISE	CFM	RISE	CFM	CFM	CFM
GDS8 0453AX	High	3.0	1,353	25	1,290	26	1,246	27	1,199	28	1,149	29	1,116	1,116	1,099
	Med	2.5	1,183	28	1,113	30	1,098	30	1,052	32	1,039	32	1,006	1,012	969
	Med-Lo	2.0	980	34	946	35	920	36	900	37	896	37	885	855	804
	Low	1.5	778	43	762	44	738	45	746	45	738	45	717	696	678
GDS8 0703AX	High	3.0	1,290	40	1,236	42	1,194	43	1,166	44	1,176	44	1,166	1,108	1,029
	Med	2.5	1,139	46	1,090	48	1,035	50	1,063	49	1,063	49	1,020	962	895
	Med-Lo	2.0	962	54	927	56	925	56	941	55	909	57	877	834	779
	Low	1.5	787	66	776	67	763	68	744	70	723	72	690	641	581
GDS8 0904BX	High	4.0	2,128	31	2,063	32	2,001	33	1,927	35	1,824	37	1,726	1,628	1,529
	Med	3.5	1,840	36	1,788	37	1,745	38	1,689	39	1,625	41	1,550	1,470	1,364
	Med-Lo	3.0	1,602	42	1,558	43	1,543	43	1,493	45	1,455	46	1,402	1,328	1,239
	Low	2.5	1,277	52	1,252	53	1,244	54	1,229	54	1,214	55	1,179	1141	1079
GDS8 1155CX	High	5.0	2,405	35	2,361	36	2,250	38	2,161	39	2,037	42	1,937	1,808	1,689
	Med	4.0	1,880	45	1,838	46	1,794	47	1,734	49	1,677	51	1,568	1,510	1,401
	Med-Lo	3.5	1,659	51	1,630	52	1,587	54	1,537	55	1,492	57	1,445	1,368	1,287
	Low	3.0	1,472	58	1,454	59	1,404	61	1,366	62	1,326	64	1300	1228	1139

## GHS8

(CFM & TEMPERATURE RISE VS. EXTERNAL STATIC PRESSURE)															
MODEL	MOTOR SPEED	TONS AC <sup>1</sup>	EXTERNAL STATIC PRESSURE, (INCHES WATER COLUMN)												
			0.1		0.2		0.3		0.4		0.5		0.6	0.7	0.8
			CFM	RISE	CFM	RISE	CFM	RISE	CFM	RISE	CFM	RISE	CFM	CFM	CFM
GHS8 0453AX	High	3.0	1,739	19	1,656	20	1,601	21	1,551	21	1,513	22	1,460	1,413	1,353
	Med	2.5	1,422	23	1,399	24	1,378	24	1,350	25	1,305	26	1,275	1,220	1,178
	Med-Lo	2.0	1,207	28	1,213	27	1,197	28	1,169	29	1,158	29	1,131	1,103	1,068
	Low	1.5	991	34	980	34	958	35	950	35	937	36	924	910	874
GHS8 0704BX	High	4.0	2,097	25	2,068	25	2,012	26	1,939	27	1,869	28	1,795	1,718	1,631
	Med	3.5	1,596	32	1,566	33	1,534	34	1,492	35	1,445	36	1,401	1,354	1288
	Med-Lo	3.0	1,380	38	1,356	38	1,328	39	1,303	40	1,274	41	1,239	1,192	1127
	Low	3.0	1239	42	1191	44	1165	45	1133	46	1,104	47	1,082	1,040	996
GHS8 0905CX	High	5.0	2,382	28	2,315	29	2,234	30	2,158	31	2,078	32	1,971	1,866	1,762
	Med	4.0	1,622	41	1,603	42	1,583	42	1,556	43	1,516	44	1,482	1,422	1,359
	Med-Lo	3.5	1,436	46	1,391	48	1,387	48	1,356	49	1,325	50	1,279	1,239	1,180
	Low	3.0	1,240	54	1,214	55	1,191	56	1,157	58	1,120	60	1,083	1,052	1,025

<sup>1</sup> at 0.5" ESP

- See **Notes** on previous page.

# TEMPERATURE RISE RANGE CHART

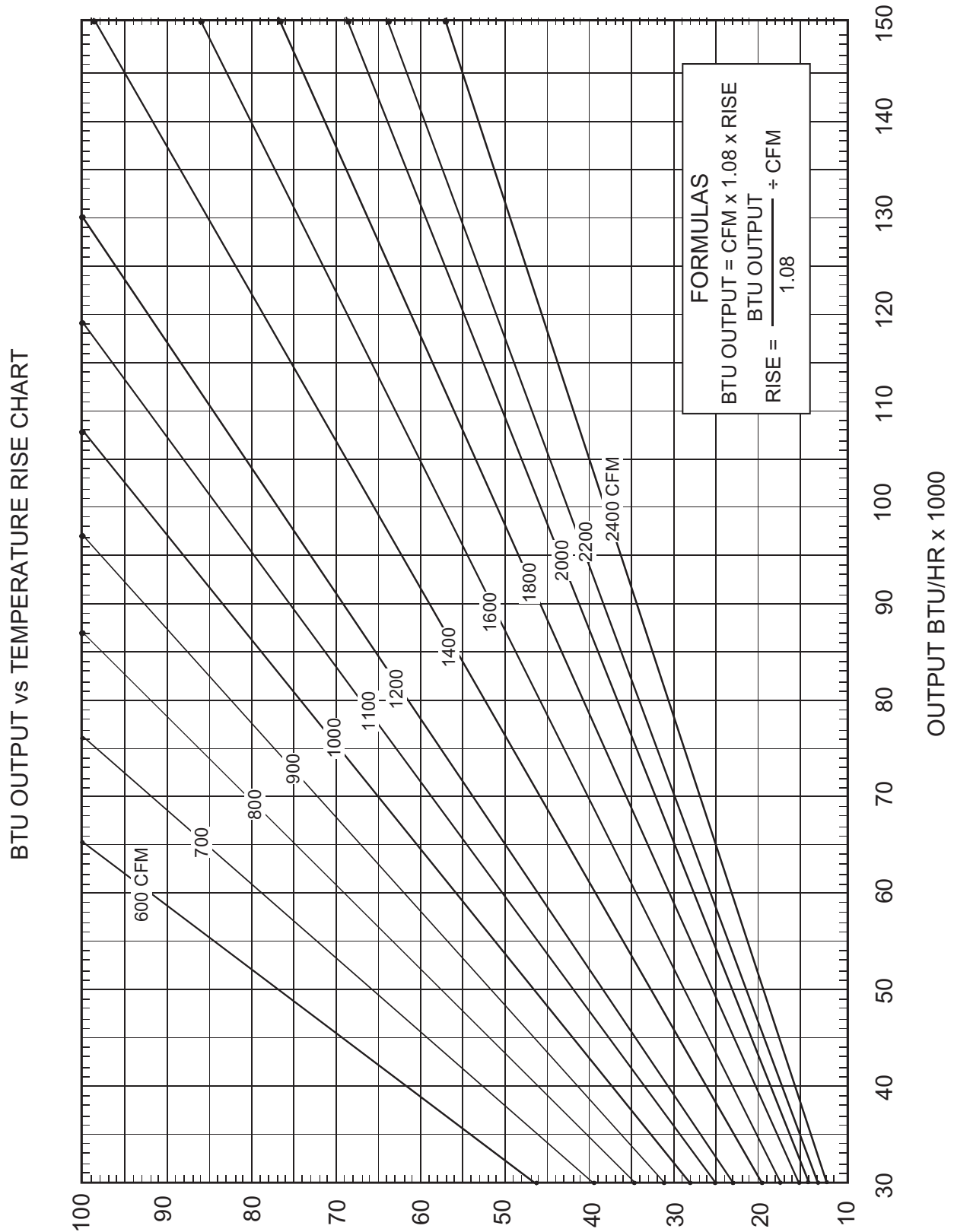

# WIRING DIAGRAM

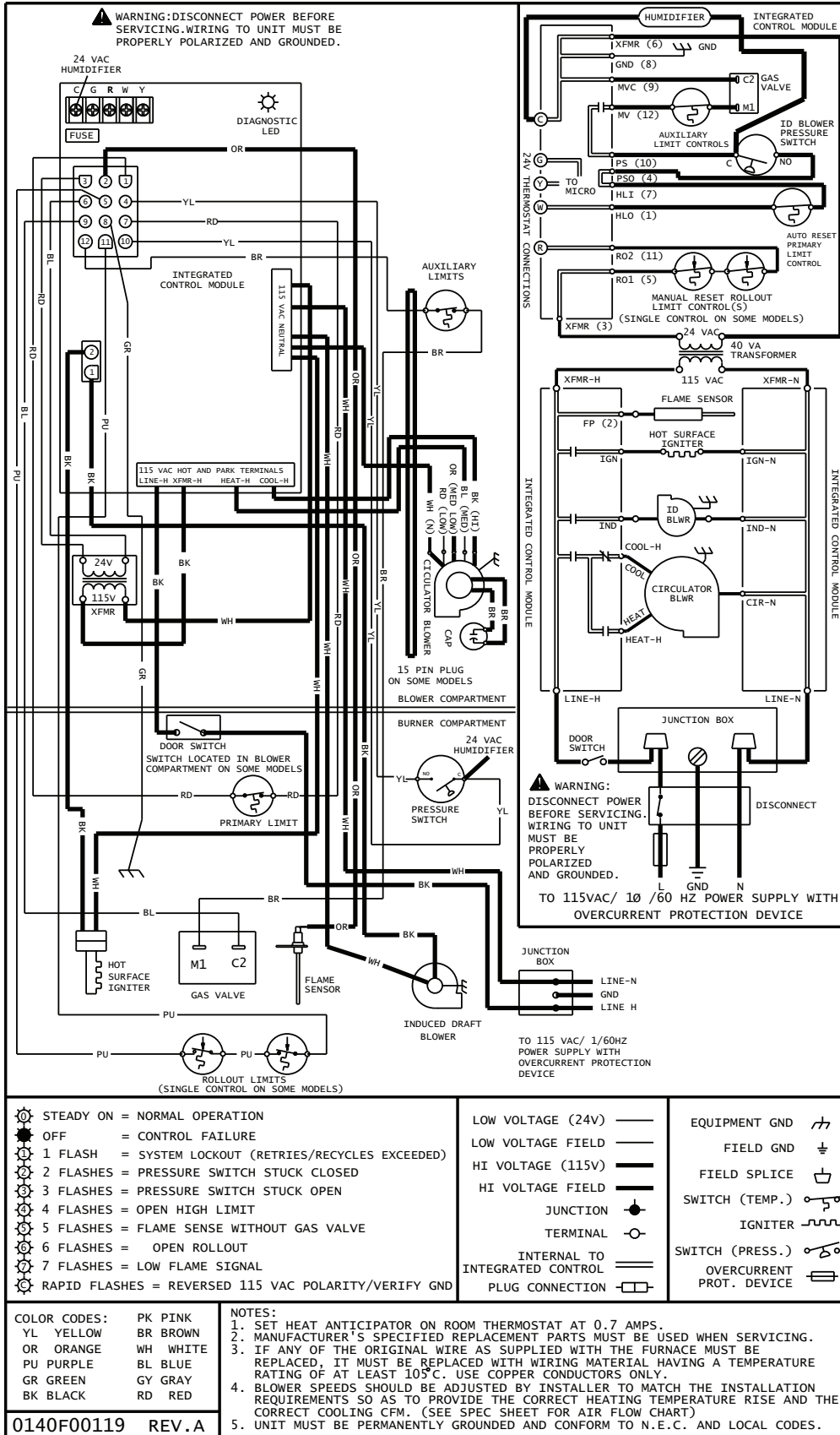

**High Voltage:** Disconnect all power before servicing or installing this unit. Multiple power sources may be present. Failure to do so may cause property damage, personal injury, or death.

**WARNING**

Wiring is subject to change. Always refer to the wiring diagram or the unit for the most up-to-date wiring.

## ACCESSORIES

MODEL	DESCRIPTION	GMS8 ALL MODELS	GDS8 0453AXB	GDS8 0703AXB	GDS8 0904BXB	GDS8 1155CXB	GHS8 0453AXB	GHS8 0704BXB	GHS8 0905CXB
LPT-00A	LP Conversion Kit <sup>1</sup>	√	√	√	√	√	√	√	√
LPT-03	LP Conversion Kit <sup>2</sup>	√	√	√	√	√	√	√	√
HA02	High-Altitude Natural Gas Kit (7,000+ ft)	√	√	√	√	√	√	√	√
AFE18-60A	Fossil Fuel Kit	√	√	√	√	√	√	√	√
FTK-03A	Twining Kit	√	√	√	√	√	√	√	√

Downflow Sub-base for:

SBT14	14" Furnace		√	√					
SBT17	17½" Furnace				√				
SBT21	21" Furnace					√			

<sup>1</sup> White-Rodgers valve only

<sup>2</sup> White-Rodgers and Honeywell valves

